

1 ENLARGE PLAN - CLERICAL SPACE
 A1.2 3/8" = 1'-0"

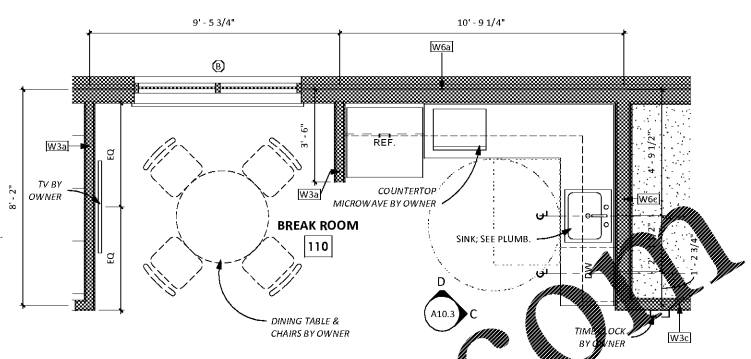

11 BREAK ROOM - ENLARGED PLAN
 A1.2 3/8" = 1'-0"

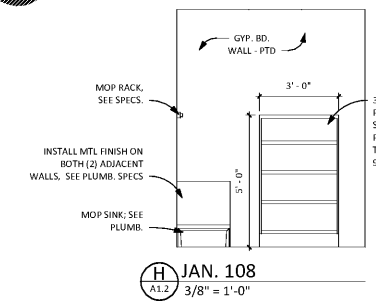

JAN. 108
 A1.2 3/8" = 1'-0"

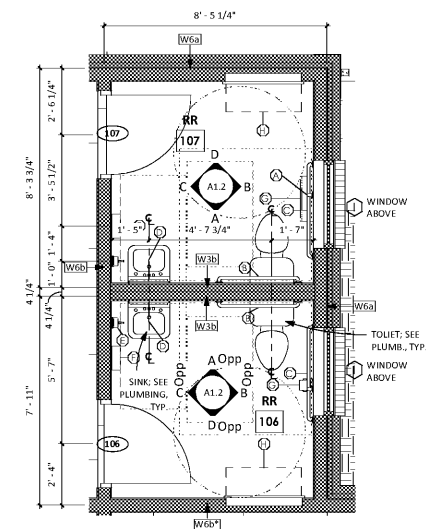

2 RESTROOMS 107 - ENLARGED PLAN
 A1.2 3/8" = 1'-0"

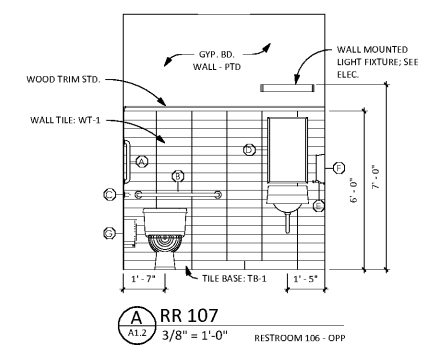

A RR 107
 A1.2 3/8" = 1'-0"

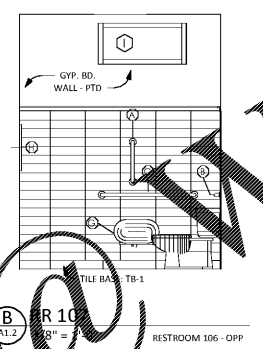

B RR 107
 A1.2 3/8" = 1'-0"

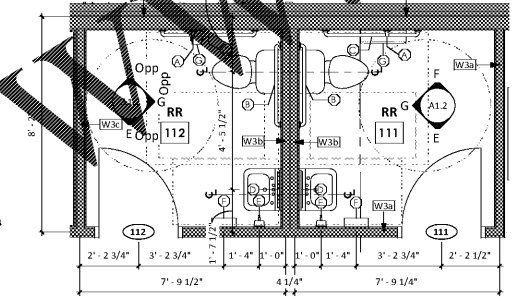

7 RESTROOMS 111 & 112 - ENLARGED PLAN
 A1.2 3/8" = 1'-0"

TOILET ACCESSORY SCHEDULE				
MARK	DESCRIPTION	MANUFACTURER	MODEL NO.	MTG HT / COMMENTS
A	18" GRAB BAR	BRADLEY CORP	8120-001180	40" A.F.F. TO CENTER (MOUNT VERTICALLY)
B	36" GRAB BAR	BRADLEY CORP	8120-001360	34" A.F.F. TO CENTER
C	42" GRAB BAR	BRADLEY CORP	8120-001420	34" A.F.F. TO CENTER
D	18" X 30" MIRROR	BRADLEY CORP	781-1830	40" TO REFLECTIVE SURFACE
E	SOAP DISPENSER	BRADLEY CORP	6562	44" A.F.F. TO DISPENSING AREA
F	PAPER TOWEL DISPENSER	BRADLEY CORP	250-15	40" A.F.F. TO DISPENSING AREA
G	TOILET TISSUE DISPENSER	BRADLEY CORP	5425	18" A.F.F. TO BOTTOM OF OPENING
H	BABY CHANGING STATION	BRADLEY CORP	9632	33" A.F.F. TO TOP OF CHANGING SURFACE
I	UTILITY SHELF	BRADLEY CORP	9984	60" A.F.F.

E RR 111
 A1.2 3/8" = 1'-0"

F RR 111
 A1.2 3/8" = 1'-0"

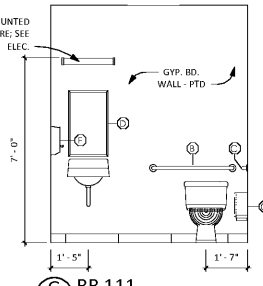

G RR 111
 A1.2 3/8" = 1'-0"

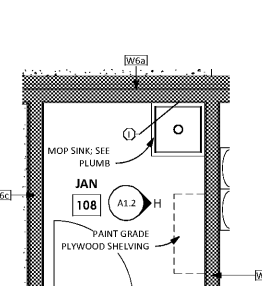

H RR 111
 A1.2 3/8" = 1'-0"

12 JANITOR - ENLARGED PLAN
 A1.2 3/8" = 1'-0"

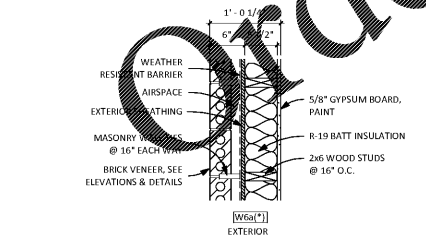

13 WALL TYPE LEGEND
 A1.2 1" = 1'-0"

GENERAL WALL TYPE NOTES

- PROVIDE SOUND INSULATION IN ALL INTERIOR WALLS.
- AT THE EXTERIOR OF ALL EXTERIOR WALLS WHERE SHOWN AT PORCHES AND CLOSE TO FINISHED TO GRADE, INSTALL 2" WIDE ADHESIVE SHEET WATERPROOFING APPLIED ON CENTER HORIZONTALLY WITH FINISH FLOOR HEIGHT.
- AT EXTERIOR BRICK VENEER WALLS, THE GENERAL CONTRACTOR MAY SUBSTITUTE BRICK VENEER WITH CONCRETE MASONRY UNITS (CMU) ONLY BELOW FINISH GRADE AT ELEVATION HEIGHTS FROM TOP OF FOOTING TO 8" BELOW FINISH GRADE.
- ALL INTERIOR SHEETROCK WALL SYSTEMS SHALL EXTEND UP TIGHT TO THE BOTTOM CHORD OF TRUSSES.
- GENERAL CONTRACTOR SHALL PROVIDE BLOCKING FOR ALL REQUIRED ITEMS SUCH AS BUT NOT LIMITED TO PLUMBING FIXTURES, BATH ACCESSORIES, ATTIC ACCESS STAIRS, TELEVISIONS, DRINKING FOUNTAINS, AND WALL HUNG COUNTERS AND CABINETS, ETC.

* AT W3a EXTERIOR WALL TYPE USED IN TAX FILE STORAGE 105, PROVIDE 5/8" TYPE "X" GYP. BD. ON INTERIOR SIDE AS REQUIRED FOR 1-HR FIRE RATING

* AT W3b INTERIOR WALL TYPE USED IN TAX FILE STORAGE 105 & RECORDS 118, PROVIDE 5/8" TYPE "X" GYP. BD. ON EACH SIDE AS REQUIRED FOR 1-HR FIRE RATING

FOR W3c WALL TYPE IN ELEC. 109 & DATA 113, PROVIDE 3/4" PLYWOOD BEHIND GYP. BD. TOWARDS INSIDE FACE OFF WALL

* AT W3d INTERIOR WALL TYPE USED IN TAX FILE STORAGE 105, PROVIDE 5/8" TYPE "X" GYP. BD. ON EACH SIDE AS REQUIRED FOR 1-HR FIRE RATING

FOR W3d WALL TYPE IN ELEC. 109 & DATA 113, PROVIDE 3/4" PLYWOOD BEHIND GYP. BD. TOWARDS INSIDE FACE OFF WALL