

1 STAND MOUNTED ELECTRIC WATER HEATER  
P0.3 N.T.S.

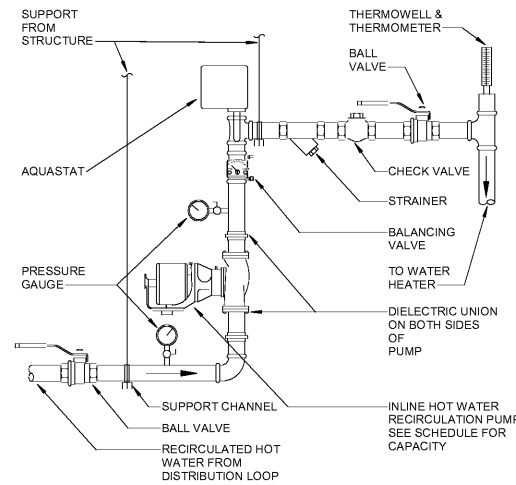

2 HOT WATER RECIRCULATION PUMP  
P0.3 N.T.S.

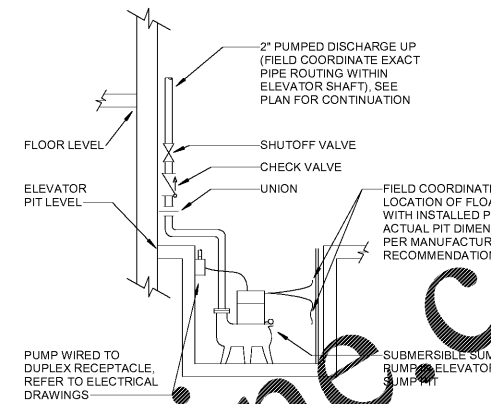

3 ELEVATOR SUMP PUMP  
P0.3 N.T.S.

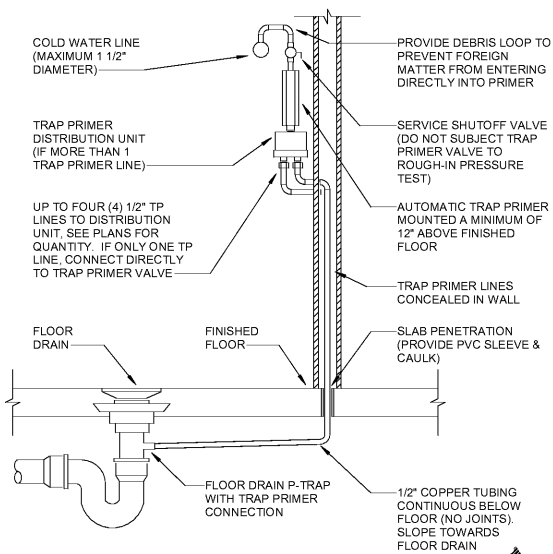

4 AUTOMATIC TRAP PRIMER  
P0.3 N.T.S.

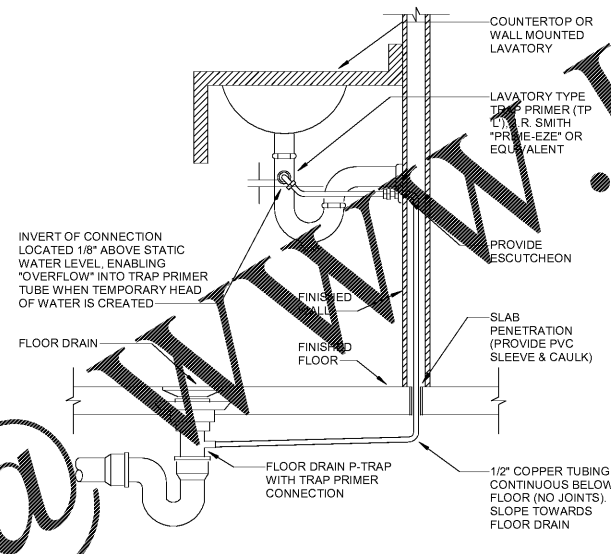

5 LAVATORY TRAP PRIMER  
P0.3 N.T.S.

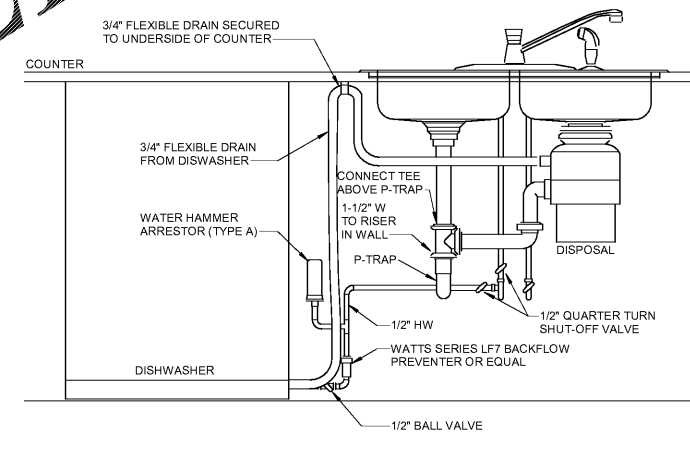

6 DISHWASHER CONNECTION  
P0.3 N.T.S.

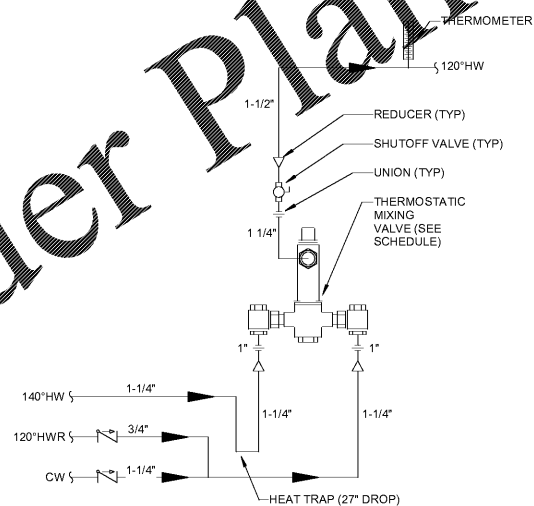

7 HI-LOW MIXING VALVE (MV-1)  
P0.3 N.T.S.

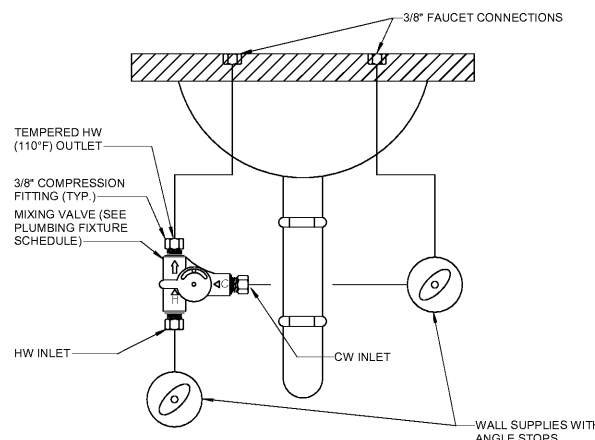

8 POINT OF USE MIXING VALVE (MV-2)  
P0.3 N.T.S.

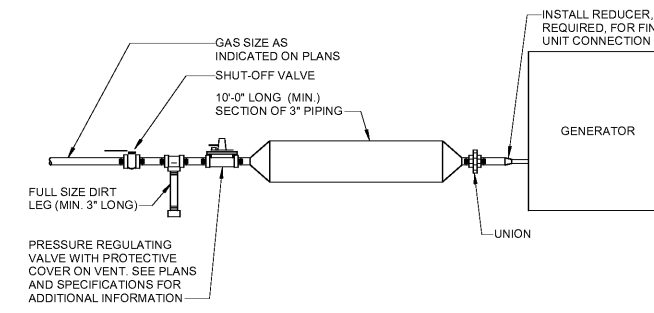

9 EQUIPMENT GAS CONNECTION  
P0.3 N.T.S.

Order Plans



CROSSFIELDS  
CHIROPRACTIC OFFICE DESIGN

3245 Brannan Parkway  
Tucker, GA 30084  
Office: 770.424.9220  
Web: www.ChiropracticOfficeDesign.com



THIS DRAWING IS THE PROPERTY OF CROSSFIELDS, INC. AND ANY REPRODUCTION OR COPYING OF THIS DRAWING, IN WHOLE OR PART IS PROHIBITED WITHOUT WRITTEN PERMISSION.

INNOVATION  
COMPOUNDING  
DR. SHAWN HODGES  
6095 PINE MOUNTAIN RD., SUITE 104  
KENNESAW, GA 30152

REVISIONS:		
NO.	DATE	DESCRIPTION

DRAWN BY: DS  
CHECKED BY: MR  
DATE: 09.24.19  
PROJECT NUMBER: 17125-IC  
SHEET NO:

P0.3

ISSUED FOR PERMITTING