

**OUTLET STRUCTURE DETAIL**  
NOT TO SCALE

NOTE:  
1. THE WIDTH OF THE BOX STRUCTURE SHALL BE A MINIMUM OF 6" OR AS REQUIRED FOR OUTLET INLET PIPE.  
2. INSTALL STEPS ON 12" VERTICAL SPACING.  
3. HOLES MUST BE PRECAST.

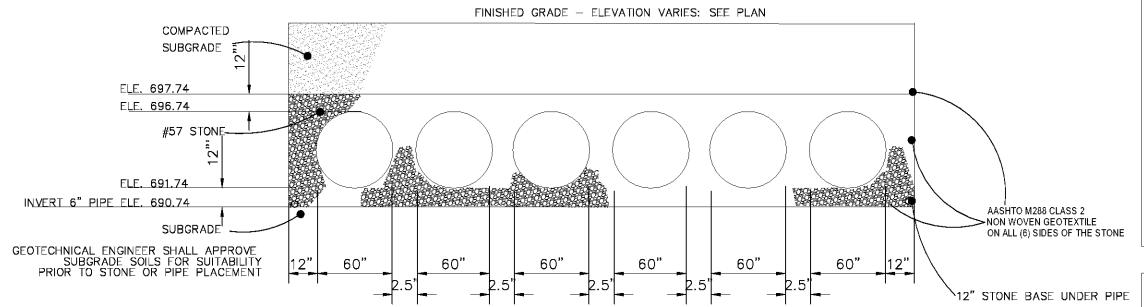

**INSPECTION & MAINTENANCE**

STEP 1) INSPECT ISOLATOR ROW FOR SEDIMENT

A. INSPECTION PORTS (IF PRESENT)

A.1. REMOVE/OPEN LID ON NYLOPLAST INLINE DRAIN

A.2. REMOVE AND CLEAN FLEXSTORM FILTER IF INSTALLED

A.3. USING A FLASHLIGHT AND STADIA ROD, MEASURE DEPTH OF SEDIMENT AND RECORD ON MAINTENANCE LOG

A.4. LOWER A CAMERA INTO ISOLATOR ROW FOR VISUAL INSPECTION OF SEDIMENT LEVELS (OPTIONAL)

A.5. IF SEDIMENT IS AT, OR ABOVE, 3" (80 mm) PROCEED TO STEP 2. IF NOT, PROCEED TO STEP 3.

B. ALL ISOLATOR ROWS

B.1. REMOVE COVER FROM STRUCTURE AT UPSTREAM END OF ISOLATOR ROW

B.2. USING A FLASHLIGHT, INSPECT DOWN THE ISOLATOR ROW THROUGH OUTLET PIPE

B.3. MIRRORS ON POLES OR CAMERAS MAY BE USED TO AVOID A CONFINED SPACE ENTRY

B.4. FOLLOW OSHA REGULATIONS FOR CONFINED SPACE ENTRY IF ENTERING MANHOLE

B.5. IF SEDIMENT IS AT, OR ABOVE, 3" (80 mm) PROCEED TO STEP 2. IF NOT, PROCEED TO STEP 3.

STEP 2) CLEAN OUT ISOLATOR ROW USING THE JETVAC PROCESS

A. A FRED CULVERT CLEANING NOZZLE WITH REAR FACING SPREAD OF 45° (1.1 m) OR MORE IS PREFERRED

B. APPLY MULTIPLE PASSES OF JETVAC UNTIL BACKFLUSH WATER IS CLEAN

C. VACUUM STRUCTURE SUMP AS REQUIRED

STEP 3) REPLACE ALL COVERS, GRATES, FILTERS, AND LIDS; RECORD OBSERVATIONS AND ACTIONS.

STEP 4) INSPECT AND CLEAN BASINS AND MANHOLES AS PART OF THE CHAMBER SYSTEM.

**NOTES**

1. INSPECT EVERY 6 MONTHS DURING THE FIRST YEAR OF OPERATION. ADJUST THE INSPECTION INTERVAL BASED ON PREVIOUS OBSERVATIONS OF SEDIMENT ACCUMULATION AND HIGH WATER ELEVATIONS.

2. CONDUCT JETTING AND CLEANING ANNUALLY OR MORE FREQUENTLY IF INSPECTION SHOWS THAT MAINTENANCE IS NECESSARY.

**OPERATION & MAINTENANCE PLAN**

FIRST YEAR OF OPERATION: THE OWNER SHALL CONDUCT QUARTERLY INSPECTIONS OF THE UNDERGROUND PIPE STORAGE SYSTEM AND OUTLET STRUCTURE.

SECOND AND THIRD YEAR: THE OWNER SHALL CONDUCT BIENNIAL INSPECTIONS OF THE DETENTION POND SYSTEM AND THE OUTLET STRUCTURE.

FOURTH YEAR AND MORE: THE OWNER SHALL CONDUCT ANNUAL INSPECTIONS OF THE DETENTION POND SYSTEM AND OUTLET STRUCTURE.

INSPECTIONS SHALL CONSIST OF THE FOLLOWING:

- INSPECT TO VERIFY OUTLET STRUCTURE IS CLEAR OF SEDIMENT AND DEBRIS.
- INSPECT TO VERIFY THE STORM PIPE IS CLEAR OF SEDIMENT AND DEBRIS.
- INSPECT TO VERIFY THE PIPE/CHAMBERS STORAGE IS CLEAR OF SEDIMENT AND DEBRIS.
- VACUUM OUT BUILDUP OF SEDIMENT AS REQUIRED TO MAINTAIN CLEAN SYSTEM.

SEE HYDROLOGY REPORT FOR ADDITIONAL MAINTENANCE REQUIREMENTS OF WATER QUALITY UNIT(S) AND UNDERGROUND DETENTION SYSTEM.

Order Plans @ [www.LDILine.com](http://www.LDILine.com)

SA&E PROJECT NUMBER	01-615-056
BID PACKAGE/PHASING	BP-1
ISSUED FOR CONSTRUCTION	10/15/2019
<b>Southern A&amp;E</b> 7951 Troon Circle Austell, Ga 30168 (770) 419-7777 I.L.C. architects & engineers	REVISIONS
	R # Doc # Date
FACILITY CODE NUMBER: 674-0110 <b>GYMNASIUM/AUDITORIUM FOR:</b> <b>HEARD COUNTY SCHOOLS</b> 545 MAIN STREET, FRANKLIN, GA 30217 <b>HEARD COUNTY SCHOOL SYSTEM</b> FRANKLIN, GEORGIA	
CONSTRUCTION DETAILS	
	DRAWING NUMBER
	C506