



**J. B. Cobb Engineering, LLC**  
 Mechanical/Industrial  
 97 Lakeland Drive  
 Dallas, GA 30132  
 Office: (678) 363-8754  
 Fax: (678) 363-8754  
 Cell Phone: (404) 403-2126  
 jbcobbpe@bellsouth.net

**A REMODEL FOR:**  
**KROGER GA-429**  
 730 NORTH MAIN STREET  
 CEDARTOWN, GA

8-12-2019  
 CONSTRUCTION SET

**PLUMBING DETAILS**

NO.	DATE	DESCRIPTION

PROJECT NO. CPS2019-080.4  
 CAD DWG FILE: CPS2019-080.4-PL1  
 DRAWN BY: JBC  
 CHECK BY: JM/LEN

**P5.1**

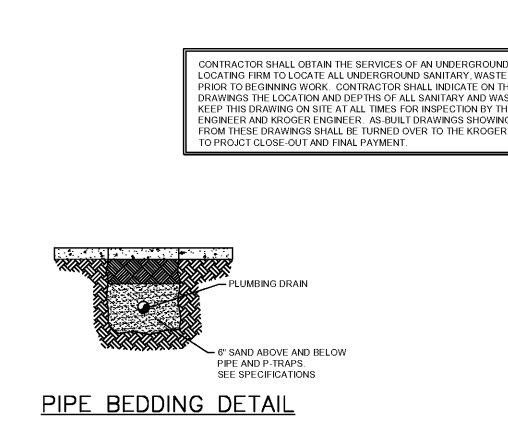
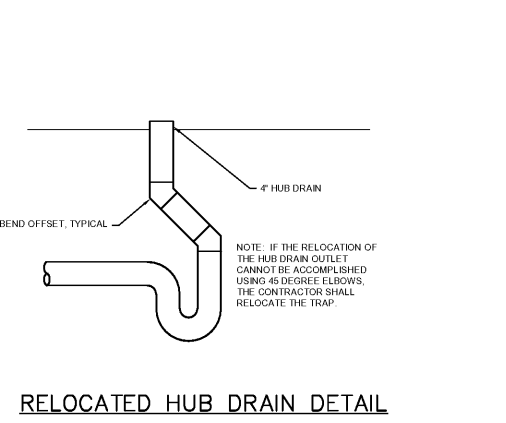
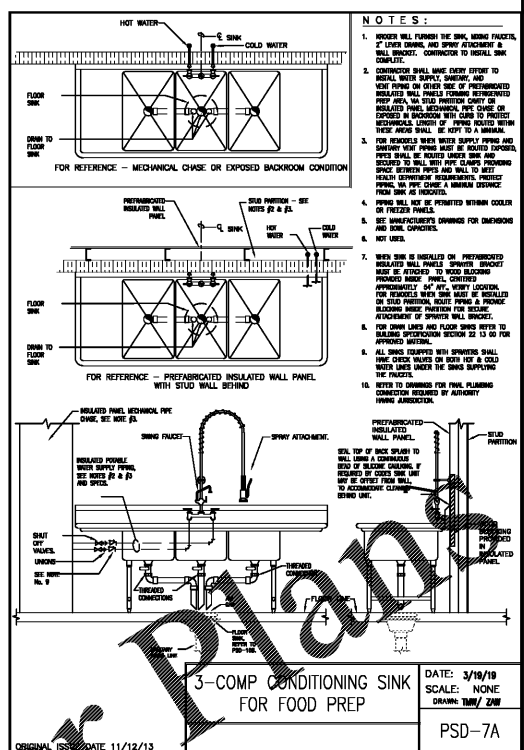
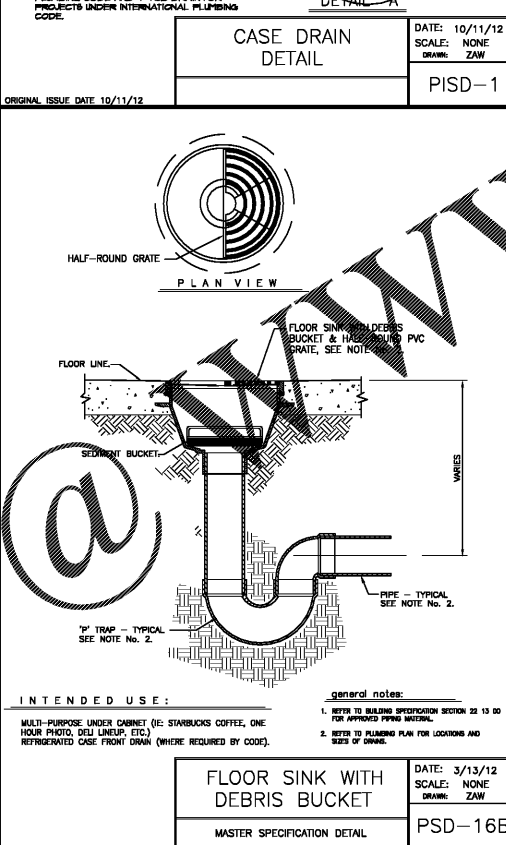
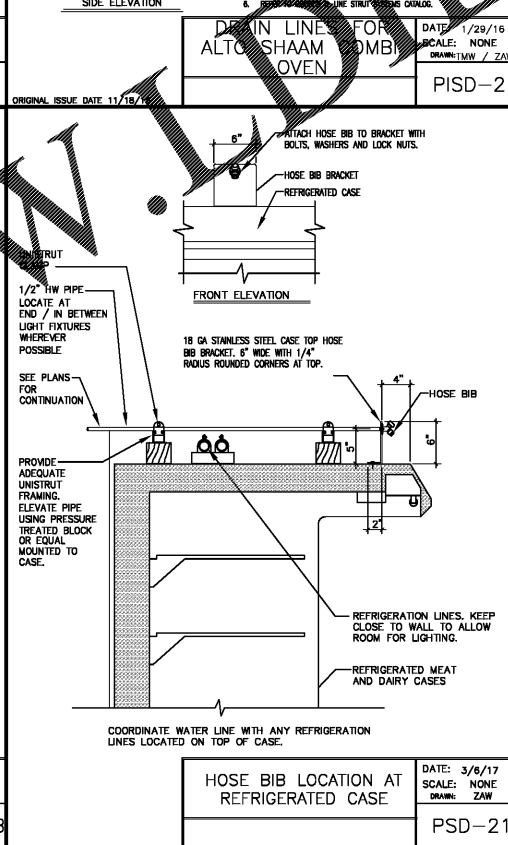
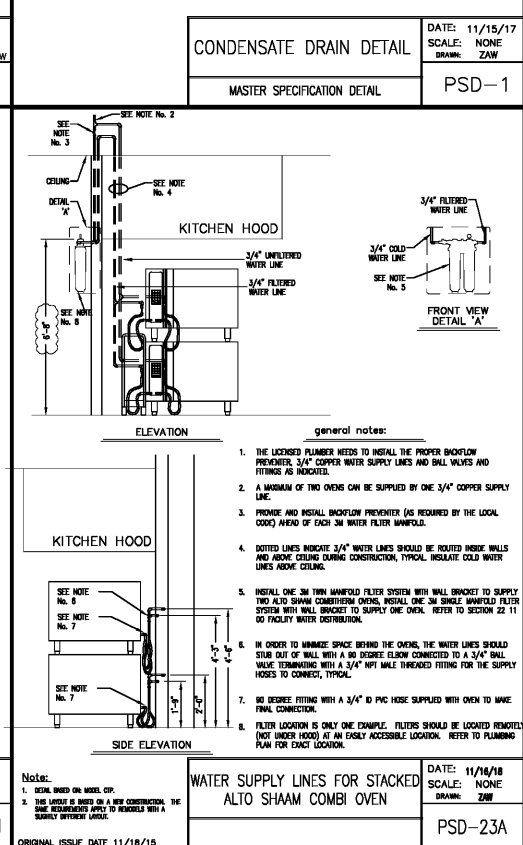
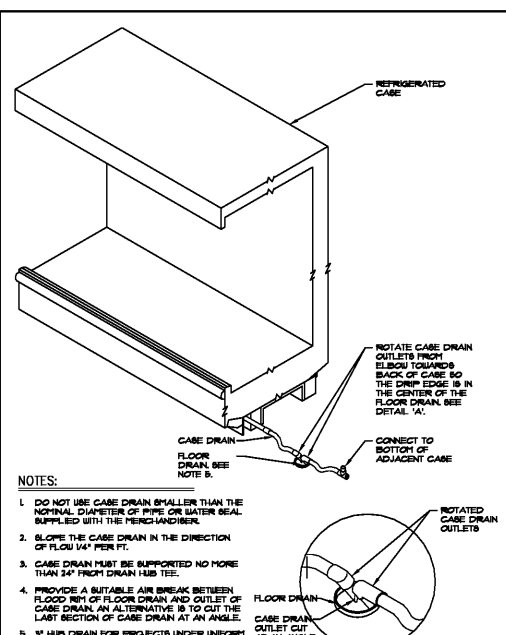
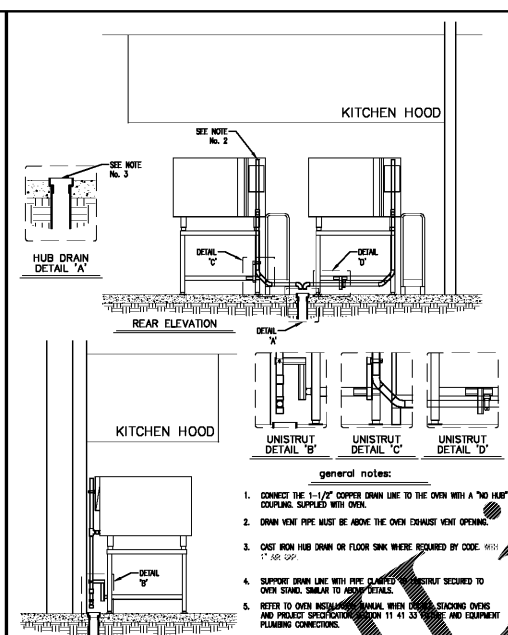
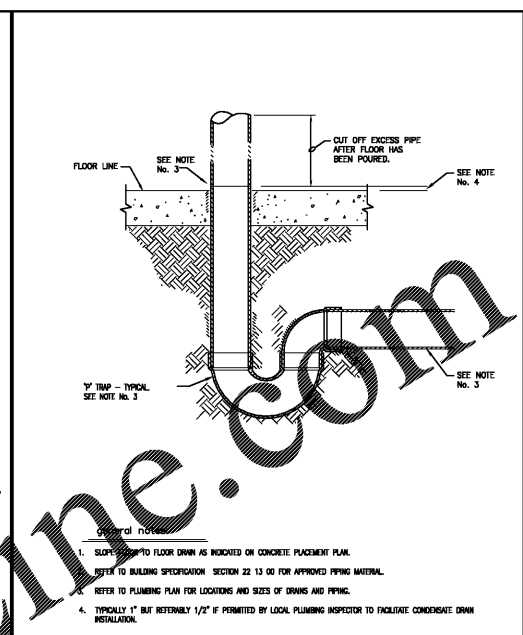

Order Plans

@WALWALDLINE.COM

CONTRACTOR SHALL OBTAIN THE SERVICES OF AN UNDERGROUND UTILITIES LOCATING FIRM TO LOCATE ALL UNDERGROUND SANITARY, WASTE AND VENT LINES PRIOR TO BEGINNING WORK. CONTRACTOR SHALL INDICATE ON THE AS-BUILT DRAWINGS THE LOCATION AND DEPTHS OF ALL SANITARY AND WASTE LINES, AND KEEP THIS DRAWING ON SITE AT ALL TIMES FOR INSPECTION BY THE ARCHITECT, ENGINEER AND KROGER ENGINEER. AS-BUILT DRAWINGS SHOWING ANY DEVIATIONS FROM THESE DRAWINGS SHALL BE TURNED OVER TO THE KROGER ENGINEER PRIOR TO PROJECT CLOSE-OUT AND FINAL PAYMENT.

ALL PIPE DROPS IN SALES AREA FROM ROOF FRAMING TO EITHER LOW WALLS OR EQUIPMENT SHOULD BE COORDINATED AND GROUPED TOGETHER WITH OTHER PIPES AND CONDUITS.

- PROJECT NOTES:**
- WORK ON THE SALES FLOOR INVOLVES PROVIDING HUB DRAINS FOR THE REFRIGERATED CASES. CONDENSATE LINES FROM THE CASES TO THE HUB DRAINS WILL BE BY THE CONTRACTOR. CONTRACTOR SHALL VERIFY ALL DIMENSIONS WITH THE CASE MFR AND THE DESIGNATED KROGER ENGINEER FOR THE EXACT LOCATIONS OF HUB DRAINS. ANY HUB DRAIN OR FLOOR DRAIN PLACED IN THE WRONG LOCATION BECAUSE OF LACK OF COORDINATION WITH THE CASE MFR OR THE KROGER ENGINEER SHALL BE REMOVED AND RELOCATED AT THE CONTRACTOR'S EXPENSE.
  - CONTRACTOR SHALL OBTAIN THE SERVICES OF AN UNDERGROUND UTILITIES LOCATING FIRM TO LOCATE ALL UNDERGROUND SANITARY, WASTE AND VENT LINES PRIOR TO BEGINNING WORK.
  - CLEANOUTS SHALL BE LOCATED AS REQUIRED BY LOCAL CODES AND AUTHORITIES. NO CLEANOUT SHALL BE INSTALLED UNDER STORE FIXTURES.
  - ALL UNDERGROUND WASTE AND VENT PIPING SHALL BE 4" MINIMUM SIZE, AND SHALL NOT BE INSTALLED UNDER FREEZERS. PIPE ROUTED IN COOLER OR FREEZER WALLS SHALL NOT BE PERMITTED.
  - PIPING EXPOSED TO SALES AREA OR EXPOSED IN PREP ROOMS SHALL NOT BE PERMITTED.