



Pate Design Group, Inc.
Architecture / Interiors

4168 Abbots Bridge Road
Duluth, Georgia 30097

(p) 770.814.0885
(f) 770.814.0886

Kirby@patedesigngroup.com

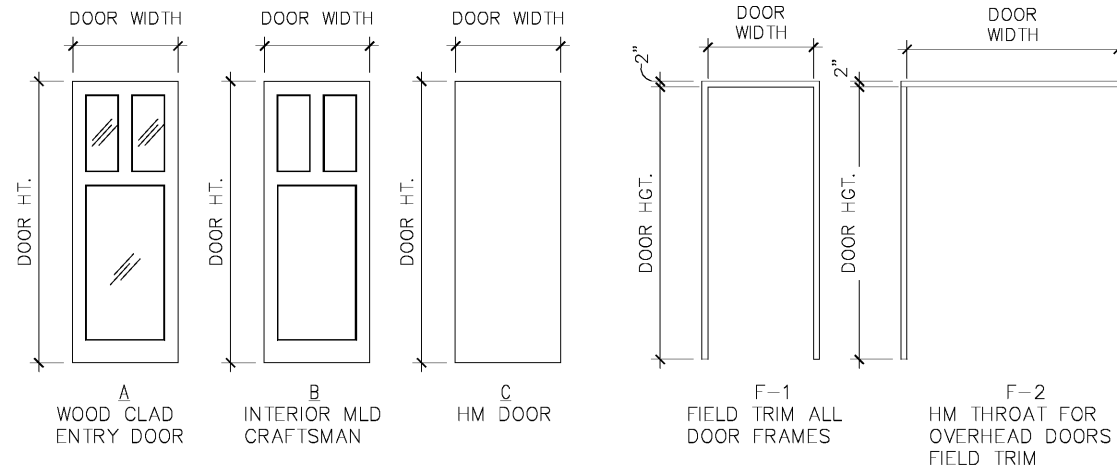

DOOR TYPES

FRAME TYPES

DOOR NO.	MATL	DOOR TYPE	DOOR SIZE	FRAME TYPE	HEAD	JAMB	SILL	SET	REMARKS
101	WD	A	30" X 80"	F1	WD	H1	J1	S2	FRENCH DOOR
102	WD	A	30" X 80"	F1	WD	H1	J1	S2	FRENCH DOOR
103	GLAZED CHD	A	80" X 80"	F1	WD	H1	J1	S2	Door & Frame by Manuf.
104	GLAZED CHD	A	30" X 80"	F1	WD	H1	J1	S2	Door & Frame by Manuf.
105	WD	B	30" X 70"	F1	WD	H2	J2	S1	CLOSER
106	WD	B	30" X 70"	F1	WD	H2	J2	S1	CLOSER
107	HM	C	30" X 80"	F1	HM	H1	J1	S2	4
108	HM	C	30" X 80"	F1	HM	H1	J1	S2	4

DOOR MATERIALS
WD = WOOD STAINED
HM = PAINTED HOLLOW METAL

1 = Entry
2 = Office
3 = Privacy
4 = Storeroom
* = By Manuf.
S = Push Pull

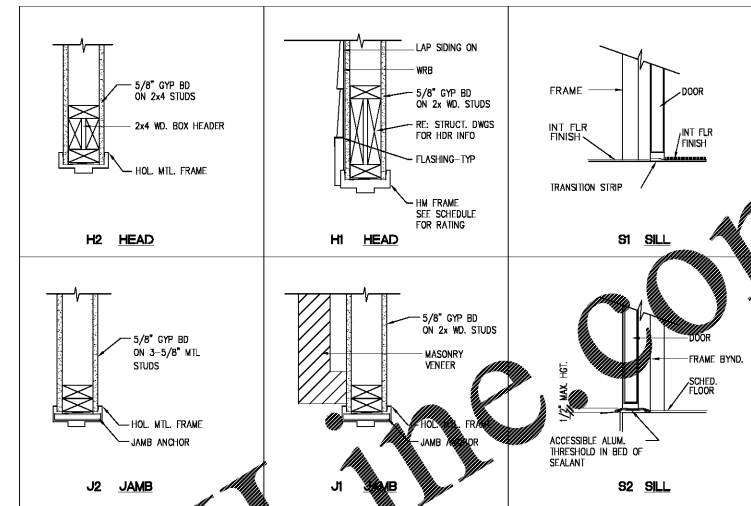

NOTE:
1. ADD SOUND BATTIS AROUND TOILET ROOMS.
2. CALK OR SEAL JOINTS EXPOSED TO EXTERIOR CONDITIONS.
3. PRIME AND PAINT METAL SURFACES.
4. SEE EXTERIOR FINISHES.

ROOM NUMBER	SPACE	FLOOR	BASE	WALLS	CEILING	DOOR	FRAME	REMARKS
101	CLUB ROOM	CT	WD/PT	NORTH: PT, EAST: PT, SOUTH: PT, WEST: PT	GYP	9'-0"	WD/PT	HM/PT
102	WOMENS TOILET	CT	TCB	WT	GYP	8'-0"	WD/PT	HM/PT
103	MENS TOILET	CT	TCB	WT	GYP	8'-0"	WD/PT	HM/PT
104	POOL EQUIPMENT	CONC.	WD/PT	PT	GYP	8'-0"	WD/PT	HM/PT
105	STORAGE	CONC.	WD/PT	PT	GYP	9'-0"	WD/PT	HM/PT
106	COVERED PATIO	*			T&G STAINED	WD/PT	HM/PT	

LEGEND
LVT = LAMINATE VINYL TILE
CT = CERAMIC TILE
C2 = CARPET 2
CT = CERAMIC TILE
PT = PAINT
GMB = GYPSUM BOARD
ACT = ACOUSTICAL CEILING TILE

NOTES
1. VERIFY COLOR SELECTION WITH OWNER PRIOR TO PURCHASE/ORDER OF MATERIALS.
2. ARCHITECT TO APPROVE SUBMITTALS OF ALL FINISH MATERIALS PRIOR TO ORDER.
3. ALL FINISH MATERIALS TO BE INSTALLED IN ACCORDANCE WITH MANUFACTURER'S PRINTED INSTRUCTIONS.
4. PROVIDE PROPER TRANSITION STRIPS BETWEEN ALL FLOORING MATERIALS. ARCHITECT TO APPROVE.
5. PAINT TO BE BENJAMIN MOORE SCRUBBABLE FLAT.
6. FINISH SCHEDULE FOR TYPICAL UNIT PLAN. APPLY TO ALL UNITS.

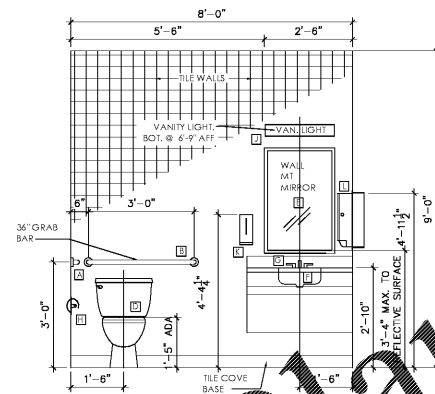

2 ELEVATION
SCALE: 1/2" = 1'-0"

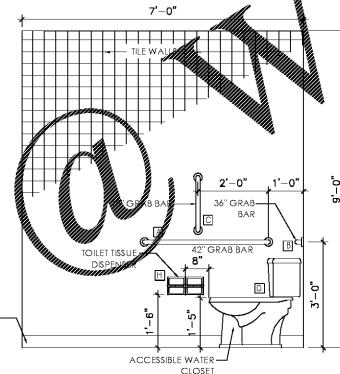

3 ELEVATION
SCALE: 1/2" = 1'-0"

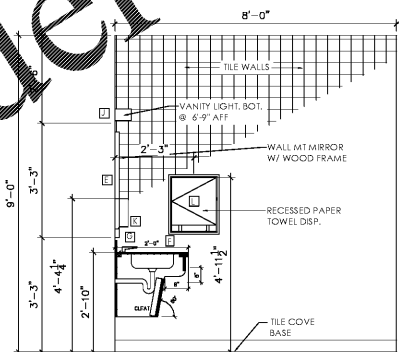

4 ELEVATION
SCALE: 1/2" = 1'-0"

BATH ACCESSORIES	
A	GRAB BAR 42"
B	GRAB BAR 36"
C	GRAB BAR 18"
D	TOILET
E	MIRROR 24" X 36"
F	UNDER COUNTER LAV
G	FAUCET
H	TOILET PAPER DISPENSER
J	VANITY LIGHT
K	SOAP DISPENSER
L	RECESSED PAPER TOWEL DISP.
RT	ROBE HOOK & TOWEL HOOK - 66" AFF

LEGEND

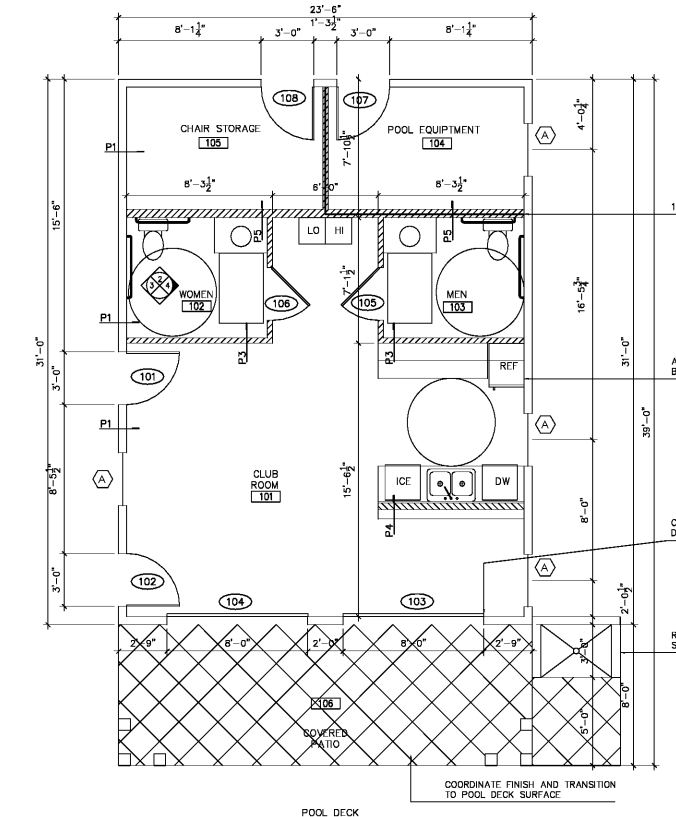

1 FLOOR PLAN
SCALE: 1/4" = 1'-0"

POOL PAVILLION
WISTERIA RIDGE
Will-O-War LLC
75 North Main Street
Watkinsville, GA 30677

Issue & Revisions:

No.	Date	Description
1	04.01.19	CLARIFICATION

FLOOR PLAN

Drawn
Checked
KEP
Contract No.
Scale
AS NOTED



030519

040119

A11

1 of 1 sheets

THIS DRAWING IS THE PROPERTY OF PATE DESIGN GROUP AND IS NOT TO BE COPIED OR REPRODUCED IN ANY MANNER. IT IS TO BE USED ONLY FOR THE PROJECT AND THE SPECIFICALLY IDENTIFIED HEREIN AND IS NOT TO BE USED IN ANY OTHER PROJECT. IT IS TO BE RETURNED UPON REQUEST.

RELEASED FOR CONSTRUCTION