

# Order Plans

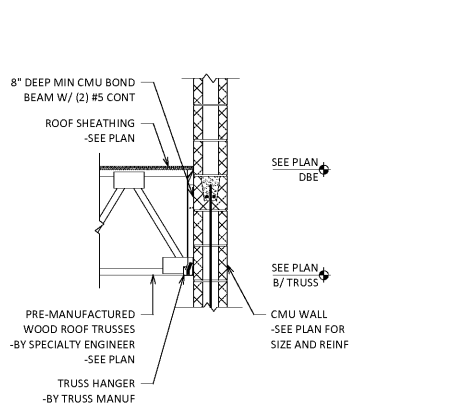

**9** SECTION AT CMU WALL PERP TO ROOF JOISTS AND CORRIDOR FRAMING  
3/4" = 1'-0"

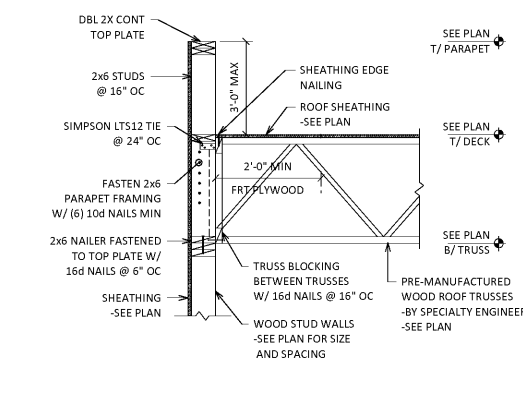

**5** PARAPET SECTION PERP TO ROOF TRUSS  
3/4" = 1'-0"

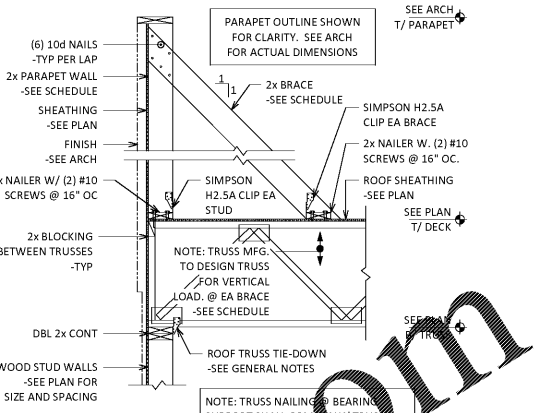

**1** TYPICAL SECTION AT PARAPET PERP TO ROOF TRUSSES  
3/4" = 1'-0"

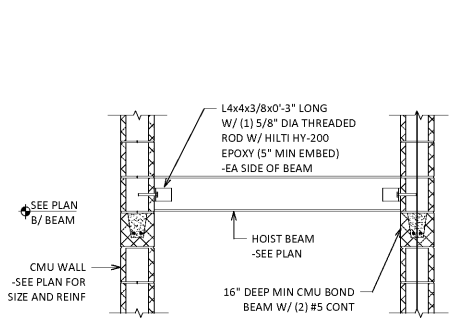

**10** SECTION AT ELEVATOR PARALLEL TO HOIST BEAM  
3/4" = 1'-0"

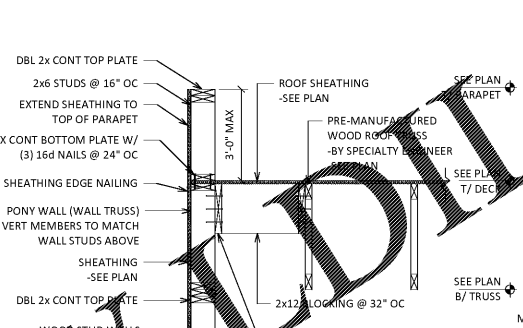

**6** PARAPET SECTION PARALLEL TO ROOF TRUSS  
3/4" = 1'-0"

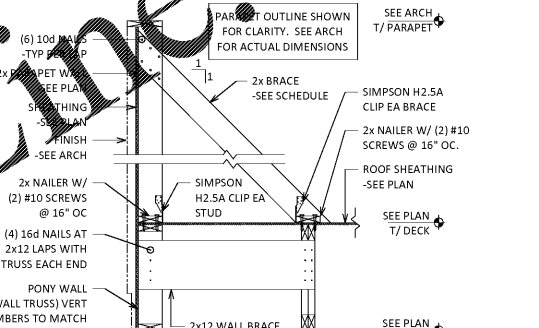

**2** TYPICAL SECTION AT PARAPET PARALLEL TO ROOF TRUSSES  
3/4" = 1'-0"

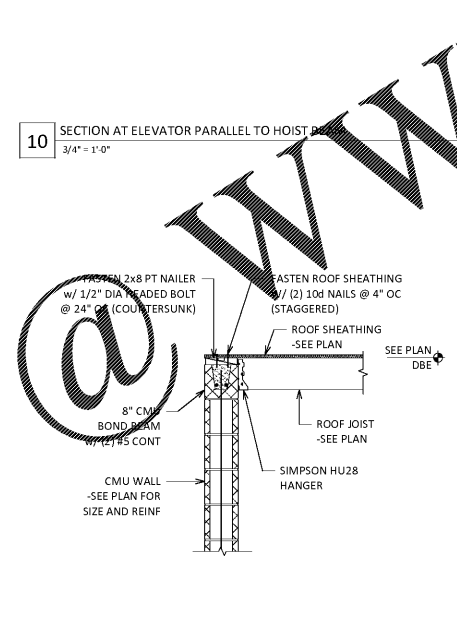

**11** SECTION AT CMU WALL PERP TO ROOF FRAMING  
3/4" = 1'-0"

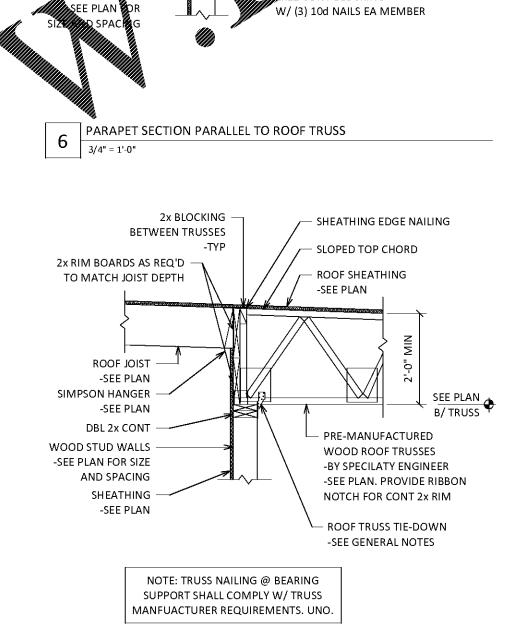

**7** TYPICAL SECTION AT ROOF OVER CORRIDOR  
3/4" = 1'-0"

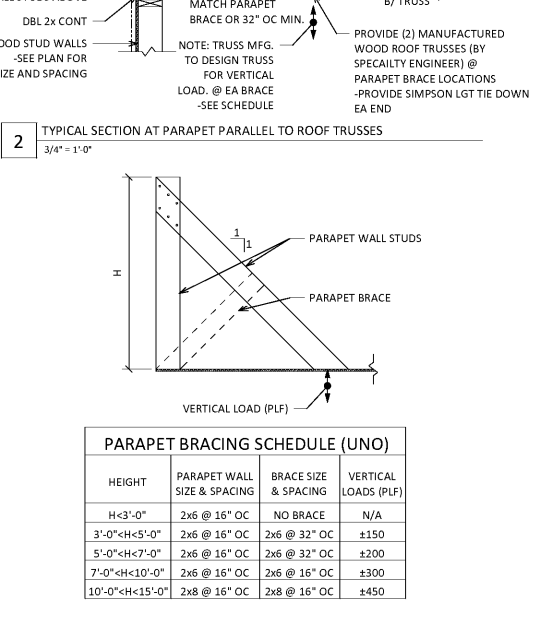

**3** PARAPET BRACING SCHEDULE  
3/4" = 1'-0"

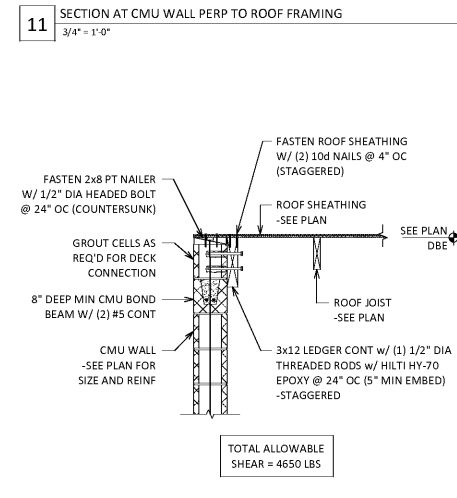

**12** SECTION AT CMU WALL PARALLEL TO ROOF FRAMING  
3/4" = 1'-0"

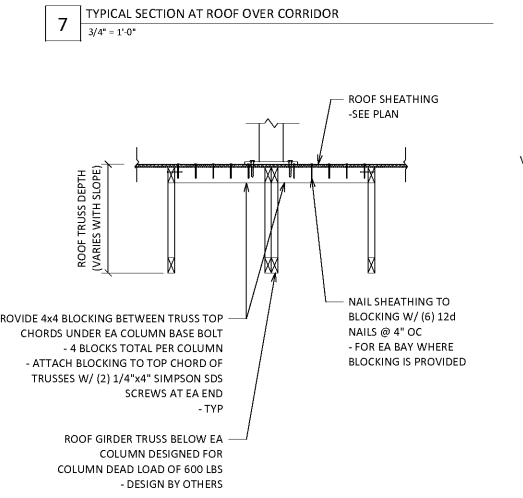

**8** CONNECTION DETAIL - POST AT ROOFTOP TRELLIS  
3/4" = 1'-0"

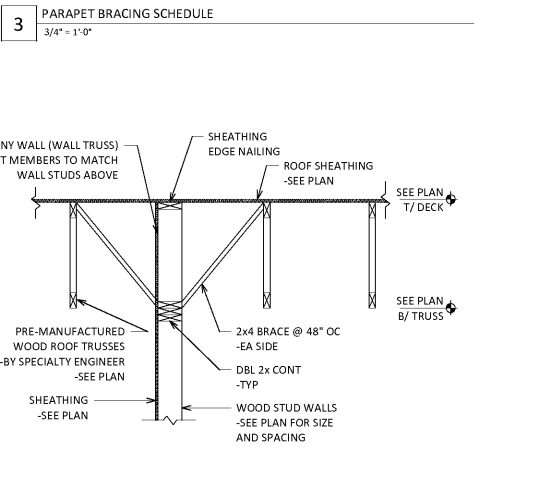

**4** TYPICAL SECTION AT ROOF OVER INTERIOR WALL  
3/4" = 1'-0"

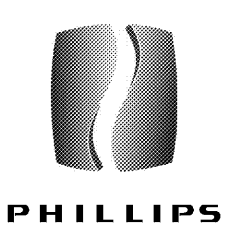

KEY PLAN

CONSULTANT  
**DVM + MEI**  
**DEL VALLE + MCNEIL, LLC**  
 Structural Engineers  
 www.dvmstructural.com  
 404.369.0058  
 Project No. 19-201027  
 GA COA #: PEF007235

ISSUE & REVISION RECORD

| # | DATE | DESCRIPTION |
|---|------|-------------|
|   |      |             |
|   |      |             |
|   |      |             |
|   |      |             |
|   |      |             |
|   |      |             |
|   |      |             |
|   |      |             |
|   |      |             |
|   |      |             |

PROJECT

**Fairfield BY MARRIOTT INN & SUITES**

**DAWSONVILLE, GEORGIA**

PROTOTYPE VERSION 2016  
 REV 1 12-01-16  
 4 STORY, 92 UNITS  
 w/ INDOOR POOL

**FAIRFIELD DAWSON FOREST ROAD DAWSONVILLE, GA 30534**

CLIENT

**RIMROCK COMPANIES**  
 10000 RIVERSIDE AVE  
 SUITE 32201  
 JACKSONVILLE, FL 32204

PHILLIPS JOB NUMBER: 1972101  
 ISSUE DATE: 08/23/2019  
 DRAWN BY/CHECKED BY: GHWT/IDV

DRAWING TITLE  
**WOOD ROOF FRAMING SECTIONS**

SHEET NUMBER

**S-4.4**

5901 PEACHTREE DUNWOODY RD.  
 BUILDING A, SUITE 450  
 ATLANTA, GEORGIA 30328  
 PHILLIPSPART.COM 770.394.1616