

3 WATER RISER DIAGRAM  
N.T.S.

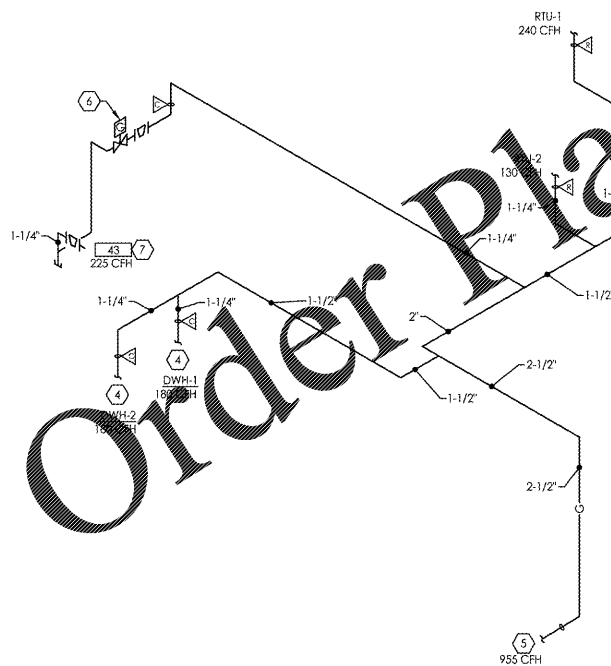

1 GAS RISER DIAGRAM  
N.T.S.

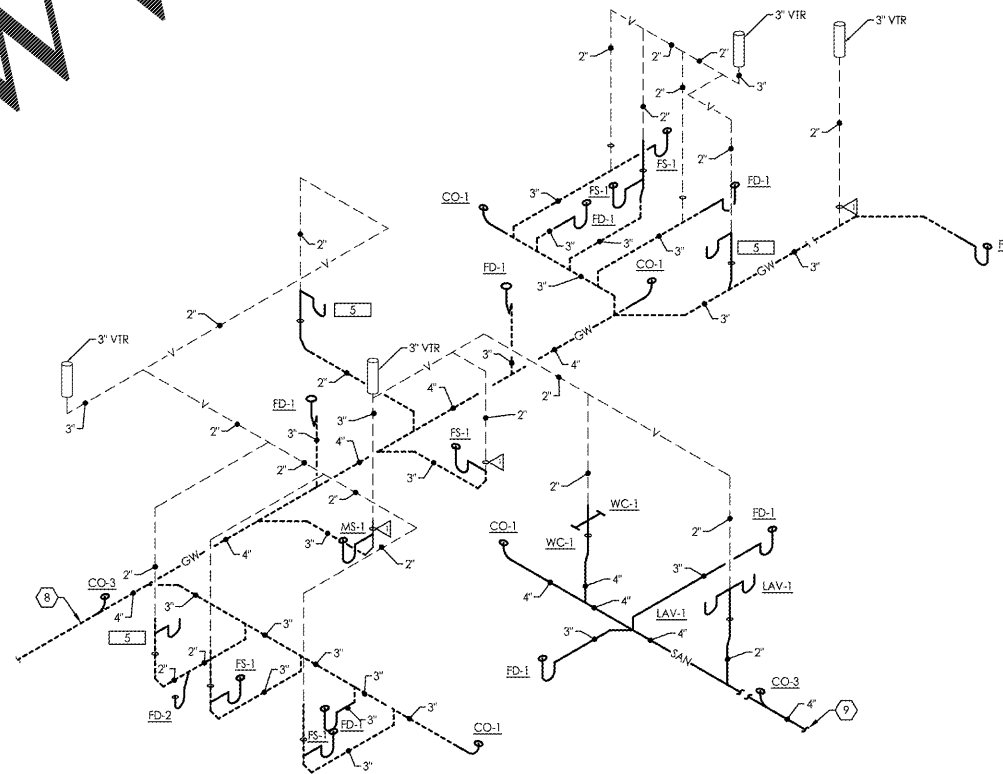

2 WASTE AND VENT STACK DIAGRAM  
N.T.S.

**CODED NOTES:** (8)

1. CONNECT TO SITE CONTRACTOR PROVIDED WATER LINE.
2. REFER TO WATER HEATER DETAIL ON SHEET P4.1 FOR CONTINUATION.
3. REFER TO WATER FILTER SYSTEM DETAIL ON SHEET P4.1 FOR CONTINUATION.
4. PROVIDE CONNECTION TO WATER HEATER. REFER TO DETAIL ON SHEET P4.1.
5. 2" NATURAL GAS FROM GAS METER. REFER TO DETAIL ON SHEET P4.2.
6. KITCHEN GAS SHUTOFF VALVE. REFER TO DETAIL ON SHEET P4.1.
7. REFER TO KITCHEN GAS EQUIPMENT CONNECTION DETAIL ON SHEET P4.1.
8. CONNECT 4" GREASE WASTE PIPING TO SITE UTILITY CONTRACTOR PROVIDED SITE GREASE WASTE SEWER 5'-0" OUTSIDE BUILDING WALL. REFER TO CIVIL DRAWINGS FOR CONTINUATION. COORDINATE EXACT POINT-OF-CONNECTION WITH SITE UTILITY CONTRACTOR AND GENERAL TRADES CONTRACTOR.
9. CONNECT 4" SANITARY DRAINAGE PIPING TO SITE UTILITY CONTRACTOR PROVIDED SITE SANITARY SEWER 5'-0" OUTSIDE BUILDING WALL. REFER TO CIVIL DRAWINGS FOR CONTINUATION. COORDINATE EXACT POINT-OF-CONNECTION WITH SITE UTILITY CONTRACTOR AND GENERAL TRADES CONTRACTOR.

**red**  
architecture + planning  
174 east long street  
suite 300  
columbus, ohio 43215  
tel: 614.487.8770  
fax: 614.487.8777

PROPRIETARY INFORMATION NOTICE  
THESE PROTOTYPICAL DOCUMENTS MAY REQUIRE REVISIONS TO CONFORM TO LOCAL, STATE, AND FEDERAL CODES, ORDINANCES OR OTHER CONDITIONS. THE DESIGN CONCEPTS EMBODIED IN THESE DOCUMENTS ARE SPECIFICALLY FOR THIS PROJECT. INFORMATION CONTAINED HEREIN REMAINS THE SOLE PROPERTY OF ARBY'S RESTAURANT GROUP. IT IS CONFIDENTIAL AND PROPRIETARY AND IS NOT TO BE COPIED, REPRODUCED, DISCLOSED OR OTHERWISE TRANSFERRED TO OTHER PARTIES IN ANY FORM WHATSOEVER WITHOUT THE EXPRESS WRITTEN CONSENT OF ARBY'S RESTAURANT GROUP.

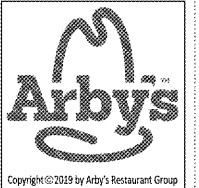

**ARBY'S RESTAURANT**  
INSPIRE WORKSMART 2400  
2385 LEN PATTERSON RD  
FORT MILL, SC 29708  
FOR  
BRUMIT RESTAURANT GROUP, LLC  
40 SEMINOLE STREET, ASHEVILLE, NC 28803

PROJECT NUMBER:  
ARF149

ISSUE	DATE
OWNER REVIEW	AUG 7, 2019

ISOMETRICS  
PLUMBING

SHEET:

**P3.1**

NOT FOR CONSTRUCTION, FOR REFERENCE ONLY