

Factory Installed Smoke Detector Specification Sheet

For Factory Installed Smoke Detectors on 2-28 ton Commercial Rooftop Units

APPLICABLE UNITS: 48/50/60, PM, PD 03-28
48/60/7C 04-30, 48/50/HC 04-25,
50T/02 04-24, 50/HC 04-12,
48/50/HE, 50/HEC 003-006
48/60/3, TM, TF 004-014
50/HA, TFO 004-012

GENERAL DATA

Type: TelAlre SuperDuct, 4-wire Photoelectric Sensing detector and control module
The Carrier Factory installed smoke detector system comprises a four-wire controller and one or two sensors (Return Air and/or Supply Air). Its primary function is to shut down the rooftop unit in order to prevent smoke from circulating throughout the building. It is not to be used as a life saving device. Factory installed smoke detectors require no additional sampling tubes to be field installed.

SYSTEM DESCRIPTION

Controller - This controller includes a controller housing, a printed circuit board, and an easily removable clear plastic cover for access to the multiple terminal connections and relay contacts for connection to fire alarm systems, HVAC controls, and other auxiliary functions. A remote test/reset/visual alarm station can be connected to the controller.

Detectors - The detector includes a plastic housing, a printed circuit board, a clear plastic cover, an exhaust tube, and a sampling tube. The exhaust tube and sampling tube are attached during factory installation. The sampling tube varies in length depending on the size of the rooftop unit. The clear plastic cover permits visual inspections without having to disassemble the sensor. The cover forms an airtight chamber around the sensing electronics.

For installations using two detectors, the controller does not differentiate which detector signals an alarm or trouble condition. A rapid change in environmental conditions, such as smoke, causes the sensor to signal an alarm state but dust and debris accumulated over time does not. When the sensor's ability to compensate for environmental changes has reached its limit (90% dirty), the sensor signals a trouble condition. Air is introduced to the dust smoke detector's sensing chamber through a sampling tube that extends into the HVAC duct and is directed back into the ventilation system through an exhaust tube. The difference in air pressure between the two tubes pulls the sampled air through the sensing chamber. When a sufficient amount of smoke is detected in the sensing chamber, the sensor signals an alarm state and the controller automatically takes the appropriate action to shut down the unit via the factory installed wiring connections. Additional functions such as integration with a Building Alarm System, additional fans and blowers, notify the fire alarm control panel, etc., require field wiring and configuration.

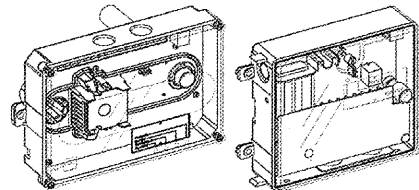

Fig. 1 - Controller and Detector (Sensor) Modules

1/2

11/1/2008

GUIDE SPECIFICATIONS

System Specifications:

- System Type: Separate controller and detector modules
- Four Wire Controller and Detector
- Photoelectric Sensing
- Environmental compensation with differential sensing for reliable, stable, and drift-free sensitivity
- Operating environment:
 - Temperature: 20° to 158°F (-29° to 70° C)
 - Humidity: 10% to 93% RH, non-condensing
- Magnet-actuated test/reset sensor switches
- Tool-free connection terminal access
- Recessed momentary switches for testing and resetting the detector

Table 1 - Controller Terminal Connections

Terminal Number	Name
1	AUX 1 (+)
2	Alarm
3	24V AC/DC COM
4	Alarm Contact COM
5	Alarm Contact NO
6	AUX 1 Contact COM
7	AUX 2 Contact COM
8	AUX 2 Contact NC
9	24V AC/DC In (+)
10	34V AC/DC In (+)
11	Not Used
12	Multi-Shutdown
13	24V AC/DC In (+)
14	24V AC/DC In (+)
15	REM Alarm LED Out
16	AUX 1 Contact NC
17	AUX 1 Contact NO
18	AUX 2 Contact COM
19	18VDC Output (+)
20	18VDC Output (-)
TRM-1	Not Used
TRM-2	Not Used
N	AC Neutral
L	AC Line

Controller specifications:

- Controller shall include:
 - One set of normally open alarm initiation contacts for connection to an existing device circuit on a fire alarm control panel
 - Two Form C auxiliary alarm relays for interface with rooftop unit or other equipment
 - One Form C supervision (trouble) relay to control the operation of the Trouble LED on a remote level-test station
 - Capable of direct connection to two individual detector modules
 - Can be wired to up to 14 ultra-dust smoke detectors for multiple fan shutdown applications

Wire Size:
High voltage terminals: 12-22 AWG
AS 100vma: 14-22 AWG
Operating voltages: 20-250 VAC, 50/60 Hz
120 VAC, 50/60 Hz
220/240 VAC, 50/60 Hz

Operating current:
20-250VDC: 175 mA
24VAC: 500 mA at 50/60 Hz
120VAC: 100 mA, 50/60 Hz
75 mA at 50 Hz
55 mA at 60 Hz
40 mA at 50 Hz
220/240 VAC, 50/60 Hz

LED indicators:
Red (Alarm)
Yellow (Trouble)
Green (Power)

Relays:
Alarm initiation relay:
Quantity: 1
Style: Normally open
Ratings: 2.0A at 30 VDC (resistive)
Auxiliary relays:
Quantity: 2
Form C
10A at 30 VDC.
Supervision (trouble) relay:
Quantity: 1
Form C
2.0A at 30 VDC (resistive)

Detector specifications:
Sensor:
8.70x5.45x1.50 in
Photoelectric
Smoke detection method:
100 - 4,000 fpm
Air velocity min-max:
0.005 - 1.00 in
Pressure differential (min-max):
0.07 to 2.48 inH₂O
Sensitivity:
14 to 22 AWG
Reset time:
Not Used
2 seconds maximum
Power up time:
8 seconds max
Alarm test response time:
5 to 7 seconds
LED indicators:
Red (Alarm)
Yellow (Trouble)
Yellow (Dirty)
Green (Power)



Turn to the Expert

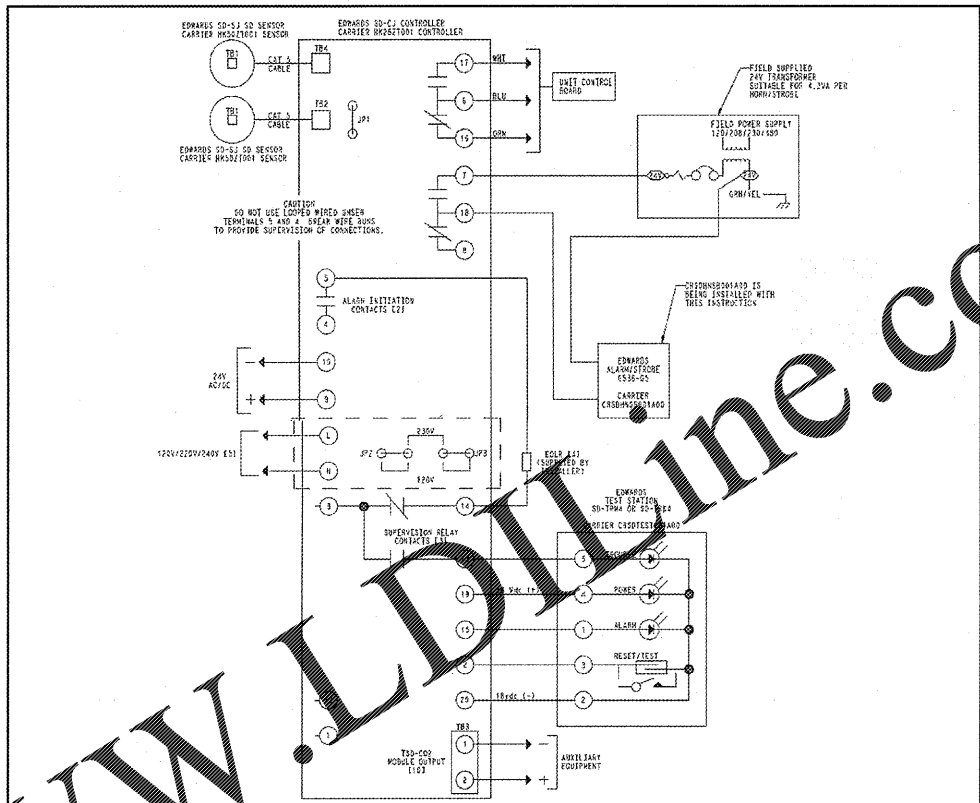

CARRIER RTU/WIRING DIAGRAM FOR CONNECTION OF DUCT DETECTOR TO TEST STATION AND ALARM/STROBE

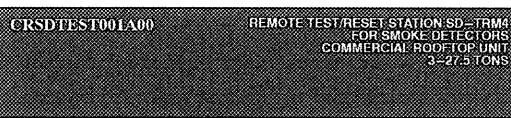

Installation Instructions

IMPORTANT: Read these instructions completely before attempting to install the accessory Remote Magnet Test/Reset Station.

SAFETY CONSIDERATIONS
Installations and servicing of air-conditioning equipment can be hazardous due to system pressure and electrical components. Only trained and qualified personnel should install, repair, or service this equipment.

Untrained personnel can perform basic maintenance functions such as cleaning and replacing air filters. All other operations must be performed by trained service personnel. When working on air conditioning equipment, observe precautions in the literature, on tags, and on labels attached to or shipped with the unit and other safety precautions that may apply.

Follow all safety codes. Wear safety glasses, protective clothing, and work gloves. Use the appropriate cloth for brazing operations. Have fire extinguisher available. Read these instructions thoroughly and follow all warnings or cautions included in literature and attached to the unit. Consult local building codes, the current editions of the National Electrical Code (NEC), NFPA 70, in Canada refer to the current editions of the Canadian electrical Code CSA C22.1.

Recognize safety information. This is the safety-alert symbol. When you see this symbol on the unit and in instructions or manuals, be alert to potential personal injury. Understand these signal words: DANGER, WARNING, and CAUTION. These words are used to highlight the most serious hazards which will result in personal injury or death. WARNING signifies hazards which could result in personal injury or death. CAUTION signifies hazards which could result in personal injury or property damage. NOTE is used to highlight suggestions which will result in enhanced installation, reliability, or operation.

WARNING
Electrical Shock Hazard
Failure to follow this warning could result in personal injury or death.
Before installing or servicing system, always turn off main power to system and install lockout tag. There may be more than one disconnect switch. Turn off accessory tester power switch if applicable.

CAUTION
Cut Hazard
Failure to follow this caution may result in personal injury.
Sheet metal parts may have sharp edges or burrs. Use care when handling parts.

WARNING
Personal Injury or Environmental Hazard
Failure to relieve system pressure could result in personal injury or death.
1. Untrained personnel and recover all refrigerant before servicing existing equipment, and before final unit disposal. Use all service ports and open all flow-control devices, including solenoid valves.
2. Federal regulations require that you do not vent refrigerant into the atmosphere. Recover during system repair or final unit disposal.

GENERAL

The SD-TRM1 Remote Test/Reset Station is used with the SuperDuct™ four-wire duct smoke detector. Each remote test/reset station provides a green LED to indicate power, a red LED to indicate alarm, and a yellow LED to indicate trouble and detector dirty levels. The SD-TRM1 requires a magnet to activate test and reset functions. (See Fig. 1.)

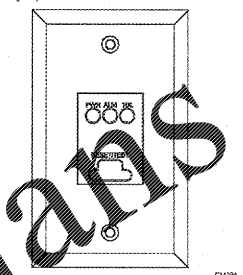

Fig. 1 - SD-TRM1

SPECIFICATIONS

Compatible Electrical Boxes:	North American 1-gang box Standard 4-in square box, 1-1/2-in deep with 1-gang cover
LED Indicators:	Alarm (red) Trouble (yellow) Power (green)
LED Type:	Clear lens
Wire Size:	14 to 22 AWG
Resistance Per Wire:	10 Ω max
Current Requirements:	Included in controller specifications
Compatible Detectors:	SuperDuct™ Four-Wire Smoke Detectors
Operating Environment:	
Temperature:	32° - 131°F (0° - 55°C)
Humidity:	85% RH, non-condensing
Storage Temperature:	-20° to 60°C (-4° to 140°F)

REMOTE TEST/RESET STATION TESTS

Test/reset station alarm test checks a test/reset station's ability to initiate and indicate an alarm state.

CAUTION
ALARM SYSTEM ACTIVATION HAZARD
Failure to follow this warning may result in emergency alarm activations and possible fines.
This test connects the duct detector into the alarm state. As part of the test, disconnect all auxiliary equipment from the controller before performing the test. If the detector is connected to a fire alarm system, notify the proper authorities before performing the test.

- To perform the alarm test using an SD-TRM1:
1. Hold the test magnet to the target area for seven seconds.
 2. Verify that the test/reset station's Alarm LED turns on.
 3. After performing an alarm test using an SD-TRM1, reset the sensor by holding the test magnet to the target area for two seconds.
 4. Verify that the test/reset station's Alarm LED turns off.

INSTALLATION

Mount the remote test/reset station on a single gang box as shown in Fig. 2.

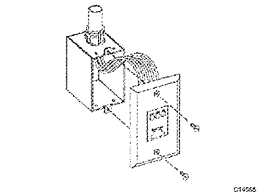

Fig. 2 - SD-TRM1 Installation Diagram

WIRING

Wire the remote test/reset station to the four-wire controller as shown in Fig. 3.

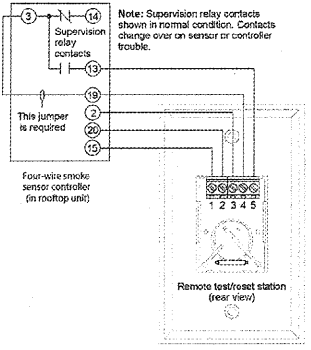

Fig. 3 - Wiring Diagram

EDWARDS SIGNALING PRODUCTS

Installation Instructions for the 6536-G5 Horn/Strobe

Description
The 6536-G5 is an audible/visual signal UL Listed for general purpose signaling applications.

Installation
A qualified electrician familiar with National Electrical Code and local code requirements must install this product. Failure to follow the safety precautions in this instruction sheet could result in product or property damage, severe personal injury or death.

WARNING
To reduce the risk of shock, do not connect terminals or lamps with unit when the circuit is energized. Do not connect AC power until installation is complete. Disconnect power and allow five (5) minutes for stored energy to dissipate before starting work or disassembly. High energy could be stored in the strobe circuit once it is energized.

The 6536-G5 horn/strobe (Figure 1) can be mounted on any single gang 2" x 4" (51 mm x 102 mm) electrical box, double gang 4" x 4" (102 mm x 102 mm) electrical box, or standard 4" x 4" (102 mm x 102 mm) junction box with a plaster ring.

1. Install an appropriate electrical box using suitable hardware.

Table 1. Specifications

Operating Voltage	24V 50/60 Hz	24V DC
Alarm Current	175 mA	125 mA

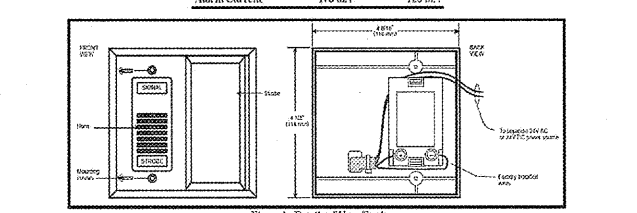

Figure 1. Details of Horn/Strobe

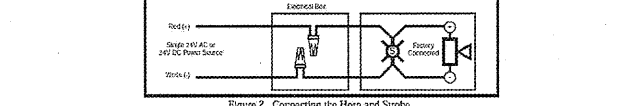

Figure 2. Connecting the Horn and Strobe

GESHIRE, CT 203-680-3200 FAX 860-677-7746 P-042550-1872 ISSUE 1 © 1999

RECEIVED
MAR 21 2008
1736 E. BROADWAY, SUITE 411
SPRINGFIELD, MO



CRAIG A. SCHNEIDER, AIA
ARCHITECT
1736 East Sunshine, Suite 417
Springfield, Missouri 65804
417.962.0558
417.962.9265
E-mail: architect@csaerichitect.com

PROJECT:
O'Reilly AUTO PARTS STORE
N. MAIN STREET
WALNUT COVE, NC
HVAC DETAILS

O'Reilly AUTO PARTS
CORPORATE OFFICES
233 SOUTH PATTERSON
SPRINGFIELD, MISSOURI 65802
(417) 862-2674 TELEPHONE

COMM # 4300
DATE: 3-22-19
REVISION
DATE:

DUCT DETECTOR - TEST STATION - ALARM/STROBE

M3