

1925 Prospect Ave.
Orlando, FL 32814
P (407) 661-9100
F (407) 661-9101
www.c-p.com

Chahaci & Peterson
Architects Engineers Planners

CLIENT NAME
WAWA
260 W. BALTIMORE PIKE
WAWA, PA 19083

PROJECT NAME
W50FEB-VA 2018 01-MA
STORE #6688-SUD
10891 DAVIDSON PLACE
MANASSAS, VA 20109

REVISION SCHEDULE

No.	Description	Date
1	PERMIT SET	01/04/2019
1	PERMIT COMMENTS	03/15/2019
1	BID SET	08/27/2019

PROJECT NO.
2770584

DATE
01/04/2019

DRAWN
PAK

CHECKED
JJD

M2

HVAC ROOF PLAN & DETAILS

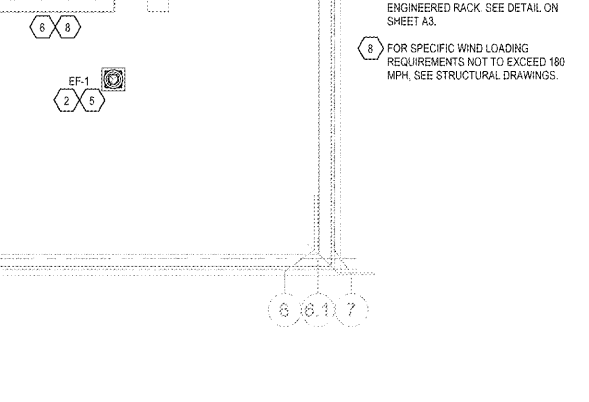
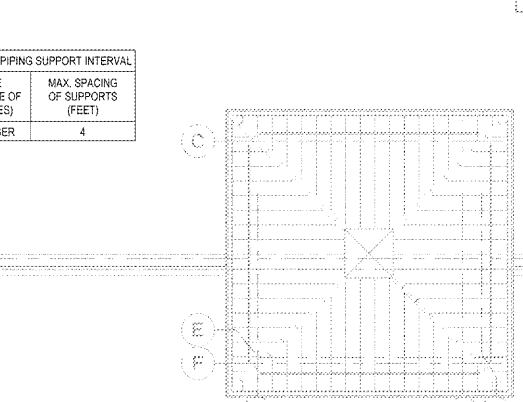
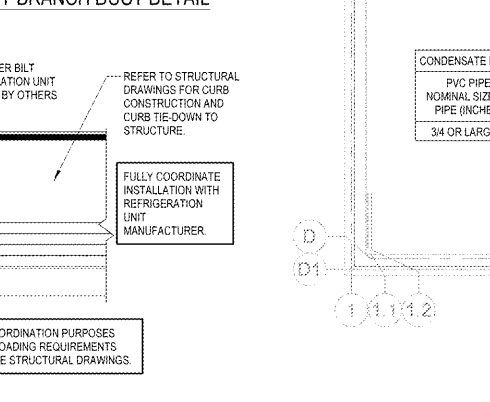
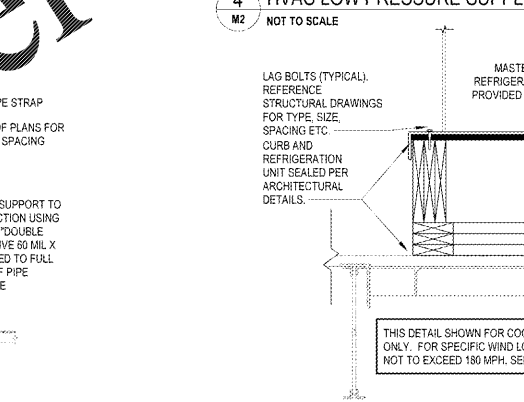
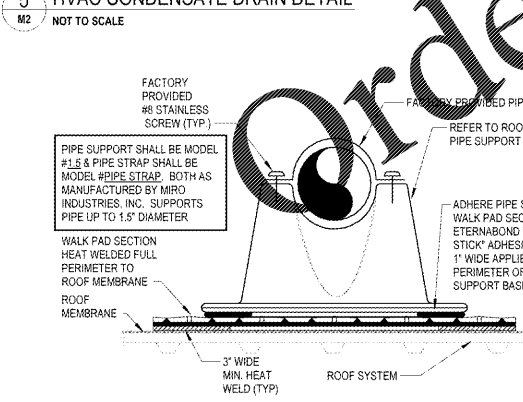
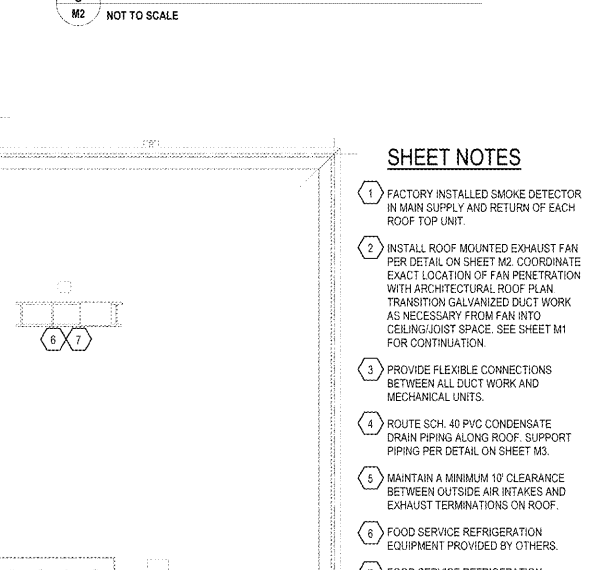
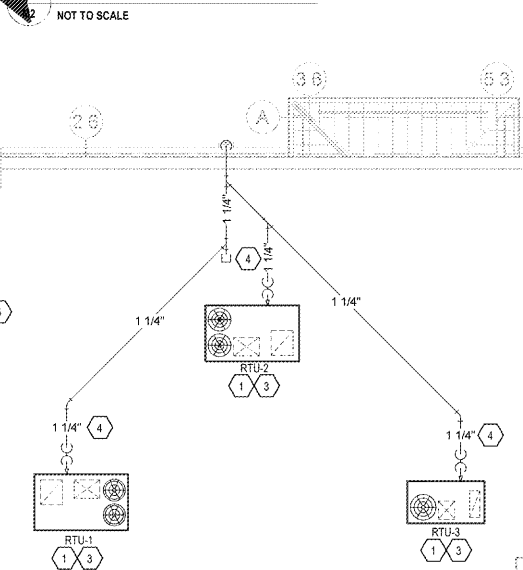
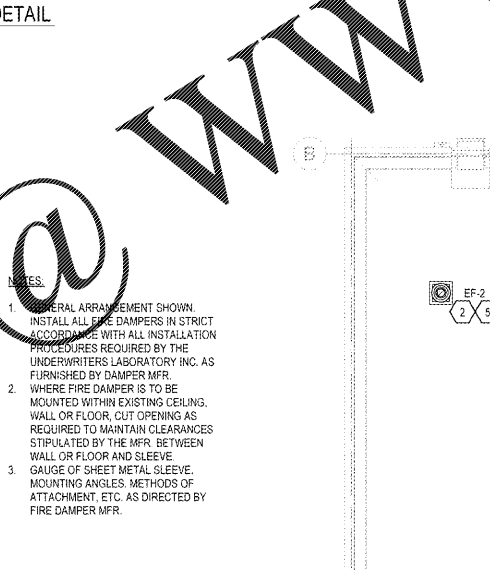
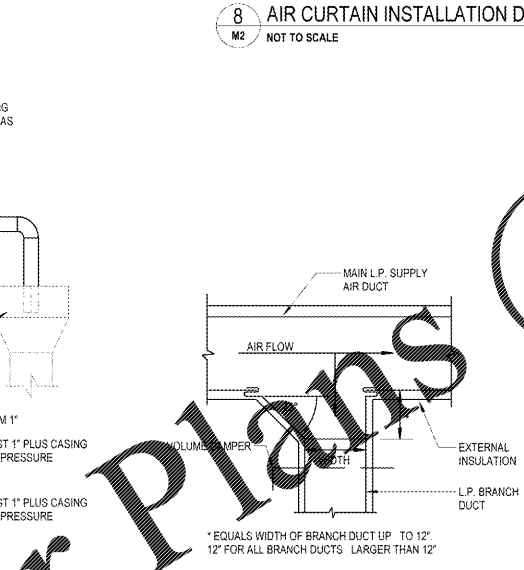
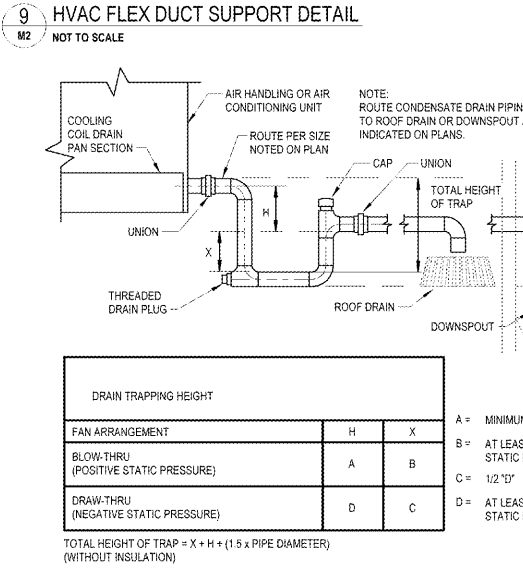
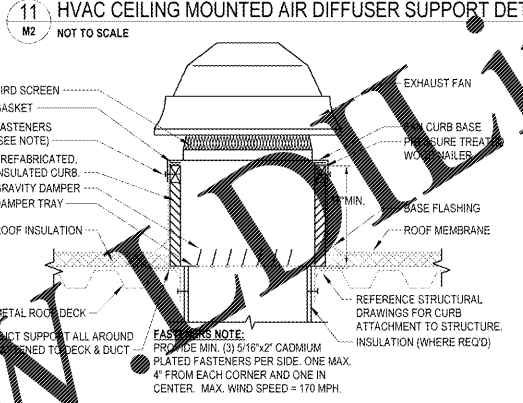
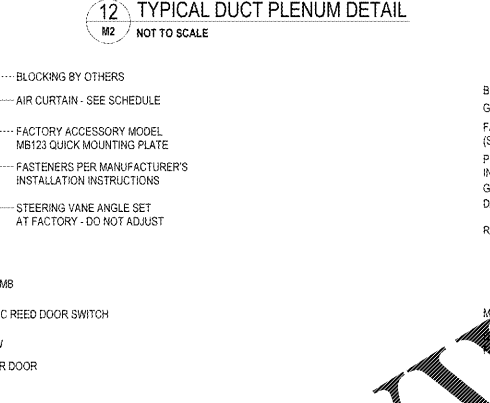
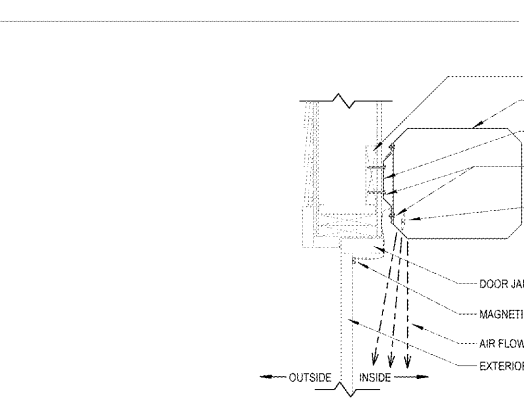
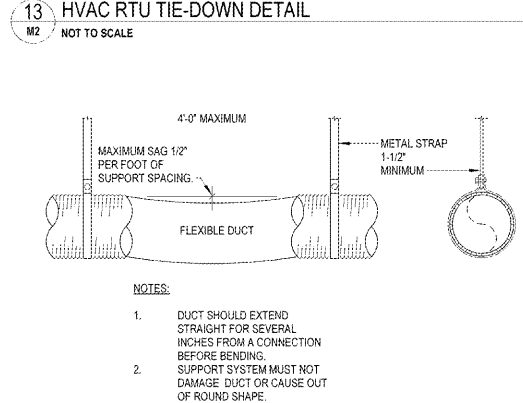
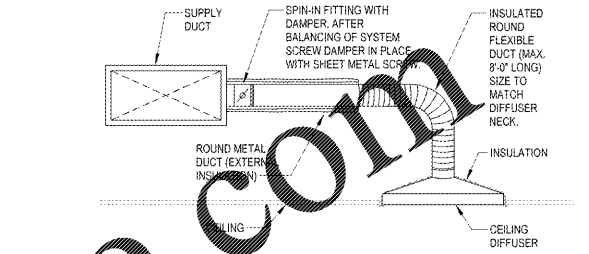
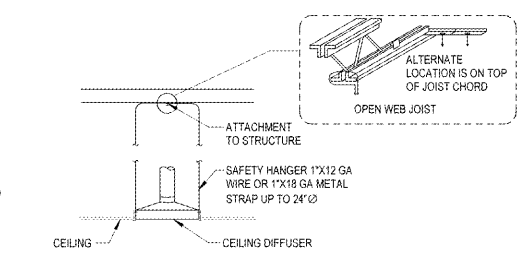
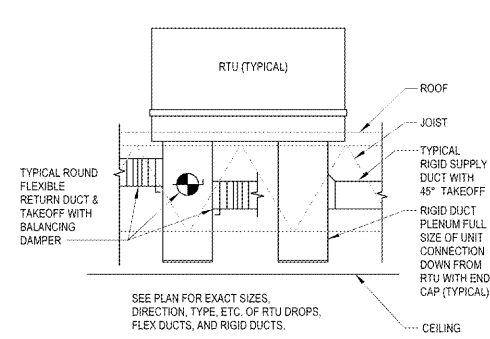
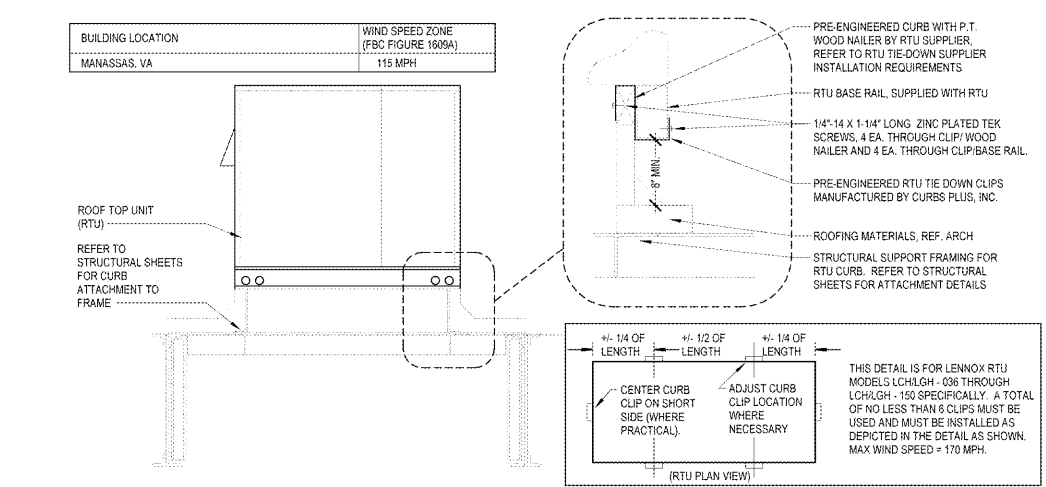

3 PIPE ROOF SUPPORT DETAIL
M2 NOT TO SCALE

2 MASTER BILT MOUNT DETAIL
M2 NOT TO SCALE

1 HVAC ROOF PLAN
M2 1/8" = 1'-0"

- SHEET NOTES**
- FACTORY INSTALLED SMOKE DETECTOR IN MAIN SUPPLY AND RETURN OF EACH ROOF TOP UNIT.
 - INSTALL ROOF MOUNTED EXHAUST FAN PER DETAIL ON SHEET M2. COORDINATE EXACT LOCATION OF FAN PENETRATION WITH ARCHITECTURAL ROOF PLAN TRANSITION GALVANIZED DUCT WORK AS NECESSARY FROM FAN INTO CEILING/JOIST SPACE. SEE SHEET M1 FOR CONTINUATION.
 - PROVIDE FLEXIBLE CONNECTIONS BETWEEN ALL DUCT WORK AND MECHANICAL UNITS.
 - ROUTE SCH. 40 PVC CONDENSATE DRAIN PIPING ALONG ROOF. SUPPORT PIPING PER DETAIL ON SHEET M3.
 - MAINTAIN A MINIMUM 10' CLEARANCE BETWEEN OUTSIDE AIR INTAKES AND EXHAUST TERMINATIONS ON ROOF.
 - FOOD SERVICE REFRIGERATION EQUIPMENT PROVIDED BY OTHERS.
 - FOOD SERVICE REFRIGERATION EQUIPMENT MOUNTED ON PRE-ENGINEERED RACK. SEE DETAIL ON SHEET A3.
 - FOR SPECIFIC WIND LOADING REQUIREMENTS NOT TO EXCEED 180 MPH, SEE STRUCTURAL DRAWINGS.

WWW.WALDLINE.COM

Order Plans @