

1 EXTERIOR BRG + NON-BRG WALL
4-STORY
SCALE: 3/4"=1'-0"

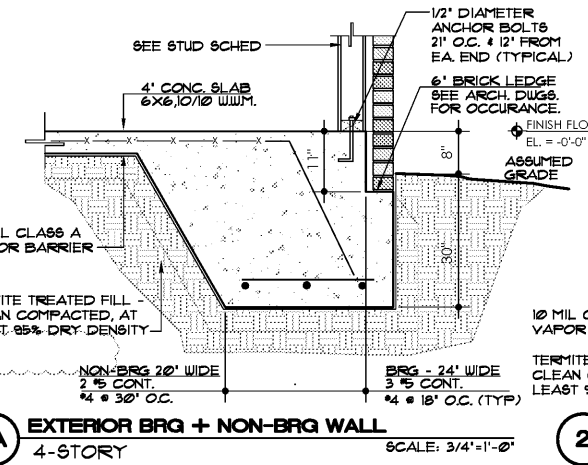

1A EXTERIOR BRG + NON-BRG WALL
4-STORY
SCALE: 3/4"=1'-0"

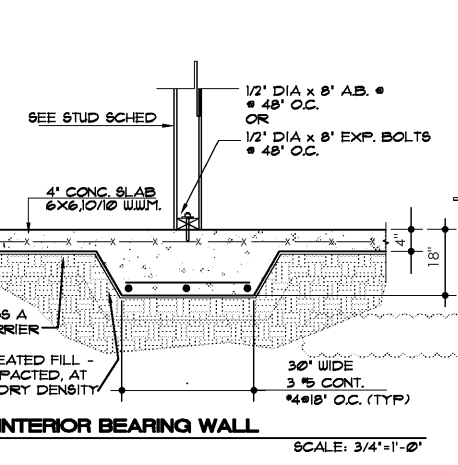

2 INTERIOR BEARING WALL
SCALE: 3/4"=1'-0"

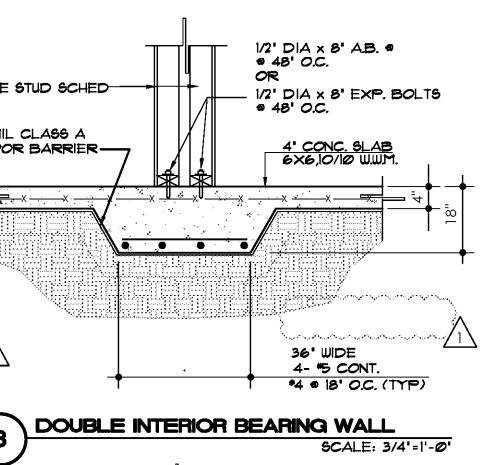

3 DOUBLE INTERIOR BEARING WALL
SCALE: 3/4"=1'-0"

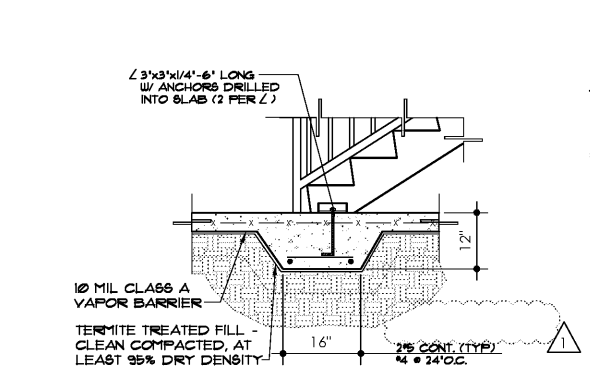

4 TYP. AT STAIR THICKEN SLAB
SCALE: 3/4"=1'-0"

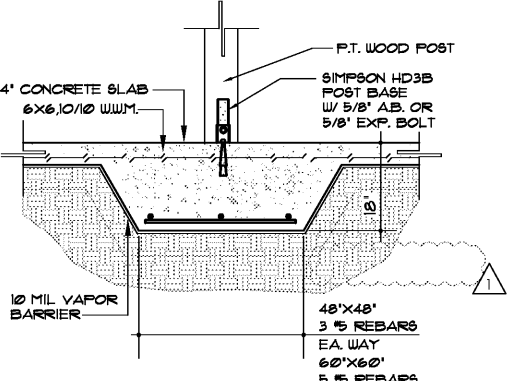

5 INTERIOR BEARING WOOD POST
SCALE: 3/4"=1'-0"

NOTE: ALL EXTERIOR FOUNDATIONS TO HAVE SLAB INSULATION, REFER TO ARCH AND MEP DRAWINGS FOR REQUIREMENTS

6 TYPICAL FOUNDATION NOTE
SCALE: N.P.

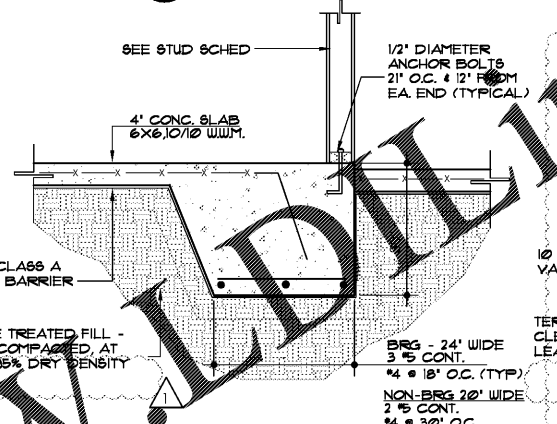

7 EXTERIOR BRG + NON-BRG WALL W/ SLAB
4-STORY
SCALE: 3/4"=1'-0"

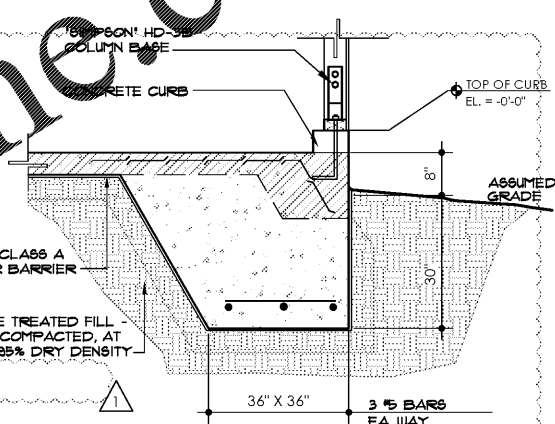

8 EXTERIOR COLUMN DETAIL
4-STORY
SCALE: 3/4"=1'-0"

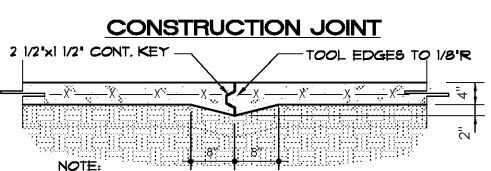

9 NOT USED
SCALE: 3/4"=1'-0"

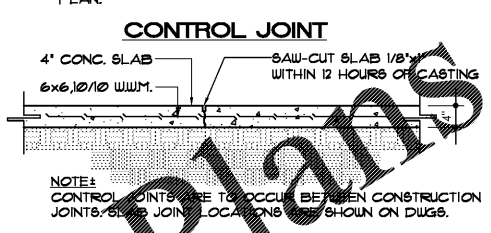

10 TYP. SLAB JOINTS
SCALE: 3/4"=1'-0"

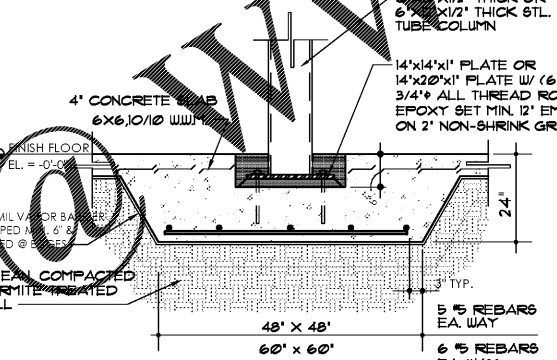

11 INT. BEARING STEEL COLUMN
SCALE: 3/4"=1'-0"

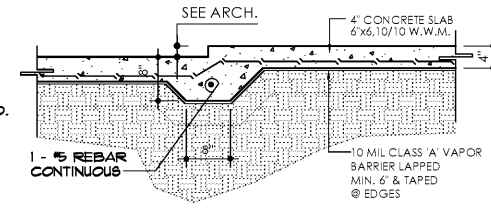

12A TURN DOWN SLAB
SCALE: 3/4"=1'-0"

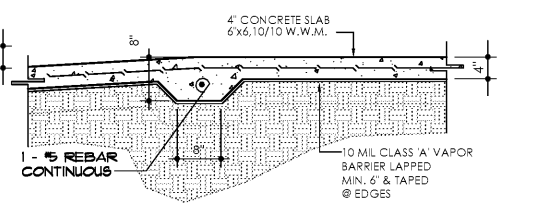

12B TURN DOWN SLAB
SCALE: 3/4"=1'-0"

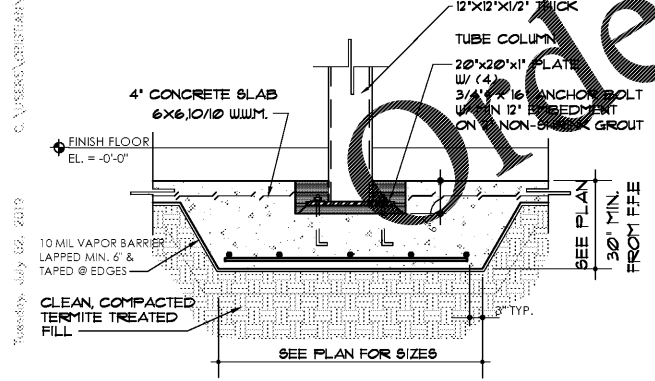

13 BEARING STEEL COLUMN AT DRIVE WAY
SCALE: 3/4"=1'-0"

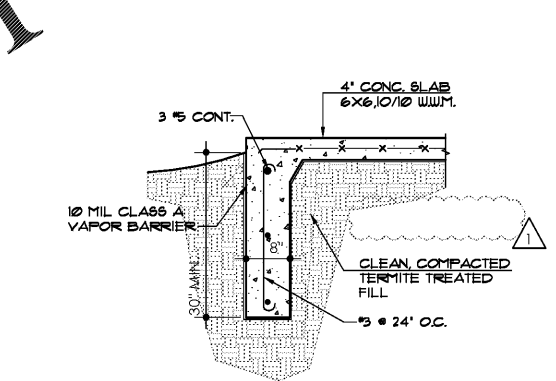

15 TYP. TURNED DOWN EDGE
SCALE: 3/4"=1'-0"

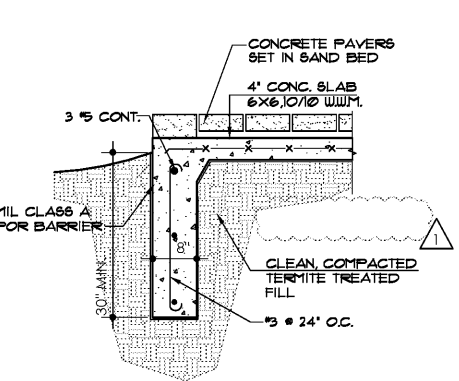

15A TYP. TURNED DOWN EDGE
SCALE: 3/4"=1'-0"

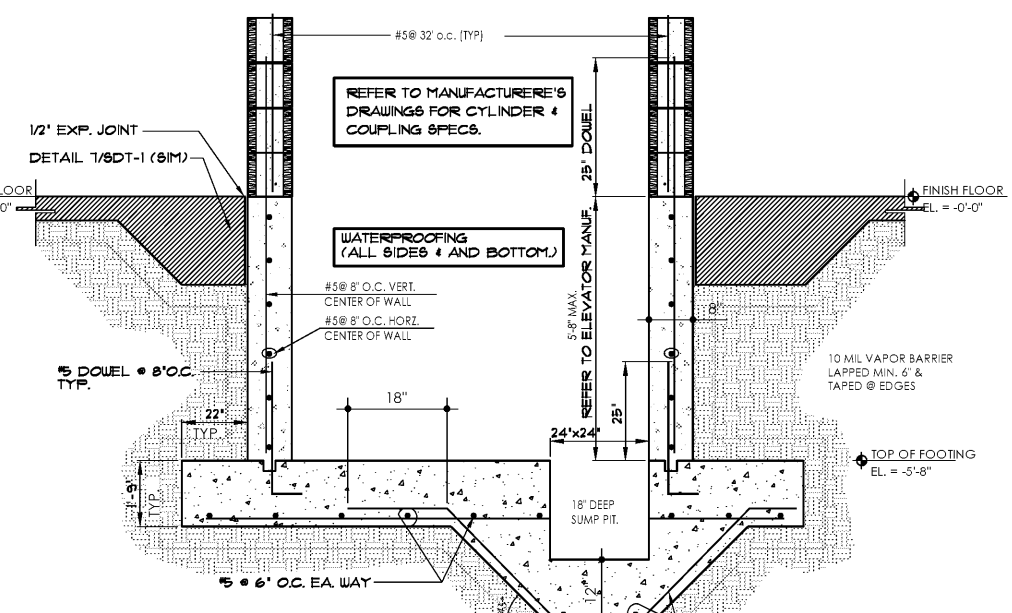

16 ELEVATOR PIT DETAIL
SCALE: 3/4"=1'-0"

Norton Commons North - Apartments

NALIN H. JOSH, PE
4-3-21 MAYWOOD DRIVE
JACKSONVILLE, FLORIDA 32277
NALIN.H.JOSH@AOL.COM
(904)744-6133

Prospect, Kentucky
Bristol Development Group
381 Mallory Station Rd, Suite 204
Franklin, TN 37067

cba
charlan • brock
associates

architects • planners
1770 fennell street
maitland florida 32751-7208
407.660.8900 f. 407.875.8948
www.cbaarchitects.com

FOUNDATION
DETAILS

date: 06-04-2019
job no: 3789.15
drawn by: CDG
reviewed by: NHJ
file: 3789SDT-1
issue history:
7-3-2019

REV1-07-03-2019

SDT-1

Charlan Brock & Associates, Inc. hereby reserves its common law copyright and other property rights in these plans, designs, and drawings. These ideas, designs, and plans are not to be reproduced, changed or copied in any form or manner whatsoever, nor are they to be assigned to any third party, without first obtaining the express written permission from c.b.a., inc. within dimensions shall have precedence over trade dimensions.