

15 BATH
UNIT C1-A SCALE: 3/8" = 1'-0"

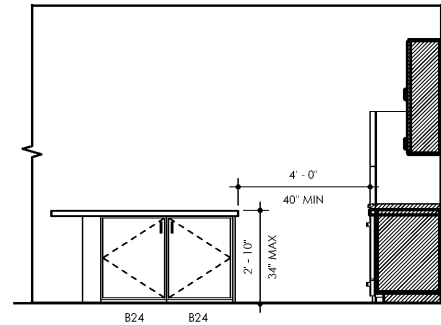

11 KITCHEN
UNIT C1-A SCALE: 3/8" = 1'-0"

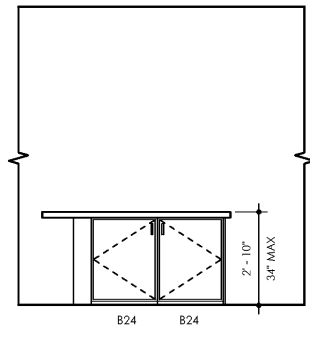

7 KITCHEN
UNIT B5-A SCALE: 3/8" = 1'-0"

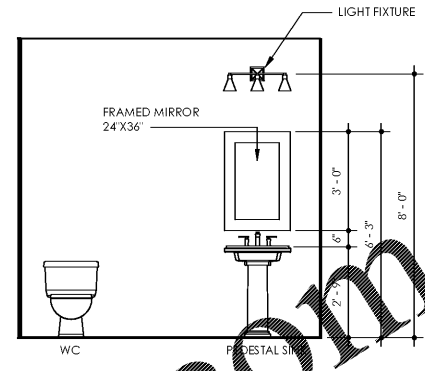

3 BATH
UNIT S1-A SCALE: 3/8" = 1'-0"

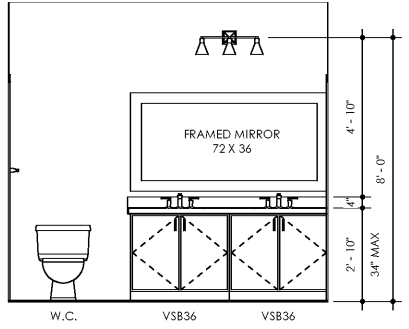

14 BATH
UNIT C1-A SCALE: 3/8" = 1'-0"

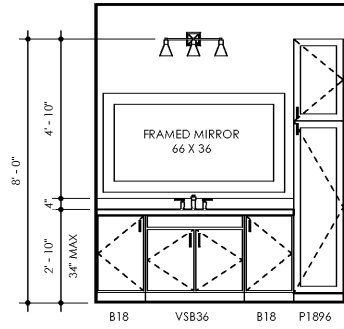

10 BATH
UNIT B5-A SCALE: 3/8" = 1'-0"

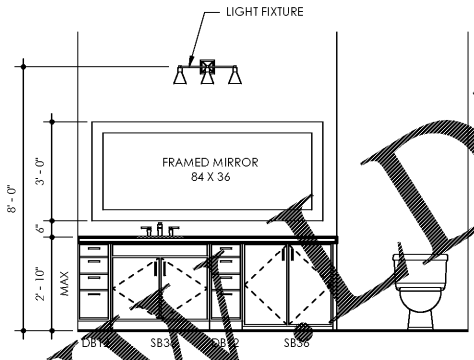

6 BATH
UNIT A4-A SCALE: 3/8" = 1'-0"

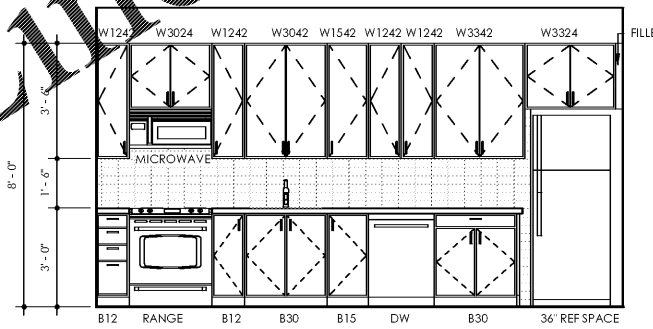

2 KITCHEN
UNIT S1-A SCALE: 3/8" = 1'-0"

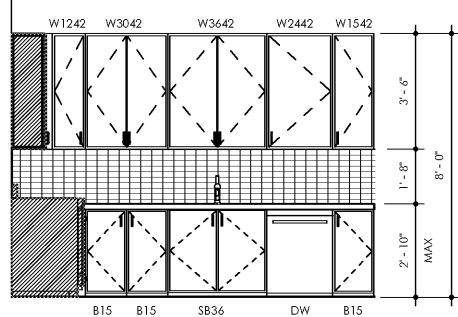

13 KITCHEN
UNIT C1-A SCALE: 3/8" = 1'-0"

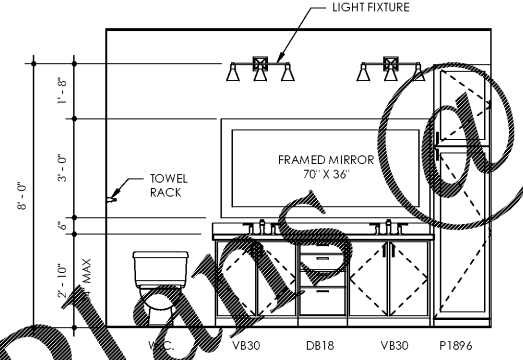

9 BATH
UNIT B5-A SCALE: 3/8" = 1'-0"

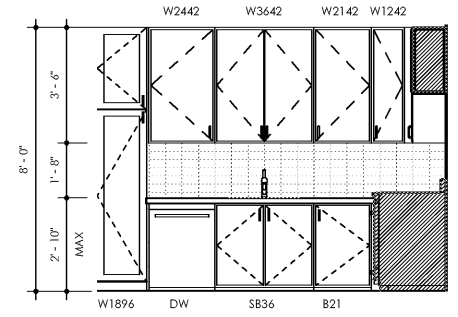

5 KITCHEN
UNIT A4-A SCALE: 3/8" = 1'-0"

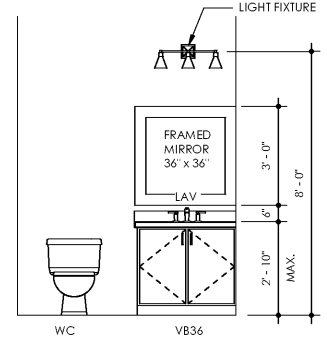

1 BATH
UNITS C3 SCALE: 3/8" = 1'-0"

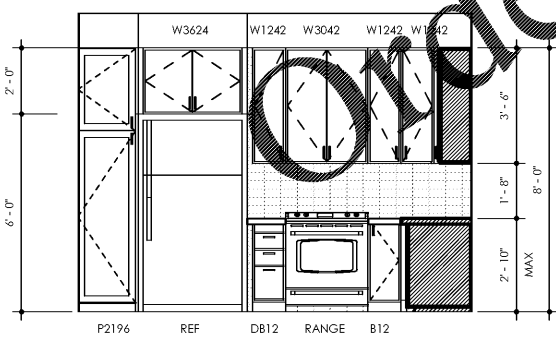

12 KITCHEN
UNIT C1-A SCALE: 3/8" = 1'-0"

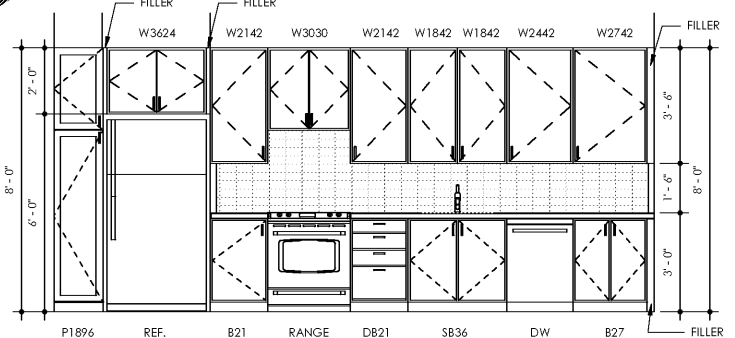

8 KITCHEN
UNIT B5-A SCALE: 3/8" = 1'-0"

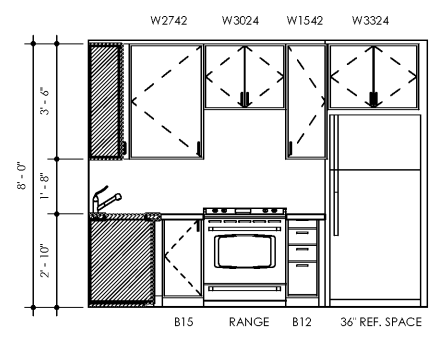

4 KITCHEN
UNIT A4-A SCALE: 3/8" = 1'-0"

GENERAL NOTES

- ALL APPLIANCES WILL BE SILVER FINISH
- ALL ACCESSIBLE OVENS/RANGES TO HAVE FRONTAL CONTROLS.
- MAXIMUM FILLER SIZE = 3"
- MICROWAVES IN ACCESSIBLE UNITS TO BE AT COUNTER LEVEL.
- 50% MINIMUM OF CABINETRY SHELVES IN ACCESSIBLE UNITS TO BE WITHIN REACH RANGE (48" HIGH MAX)

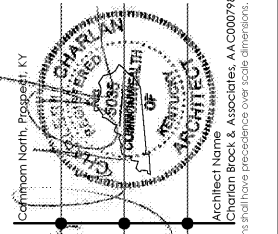

6-4-19

Lyric at Norton Commons
Prospect, Kentucky
Bristol Development Group
381 Mallory Station Rd, Suite 204
Franklin, TN 37067

charlan • brock
associates
architects • planners
1770 fennell street
maitland florida 32751-7208
407.660.8900 f:407.875.9948
www.cbarchitects.com

INTERIOR
ELEVATIONS UNIT
KITCHENS AND
BATH (TYPE A)

date: **06/04/2019**
job no: **3789.15**
drawn by: **EGR JAC, TQT**
reviewed by: **CBA**
issue history:
Δ Date

A4.95

6/4/2019 10:13:09 AM C:\Users\charlan\Documents\Projects\3789.15\Lyric_NortonCommons\B5-A\B5-A_S1-Bath_Plan.dwg