

11 BATH
UNITS A3, A3.1
SCALE: 3/8" = 1'-0"

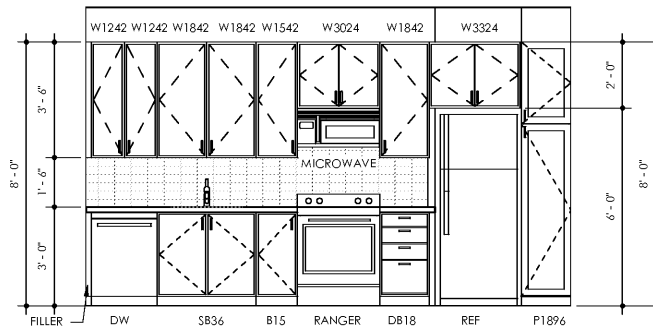

7 KITCHEN
UNITS A2
SCALE: 3/8" = 1'-0"

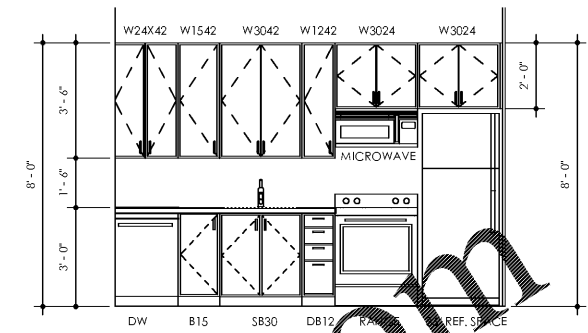

3 KITCHEN
UNIT S2
SCALE: 3/8" = 1'-0"

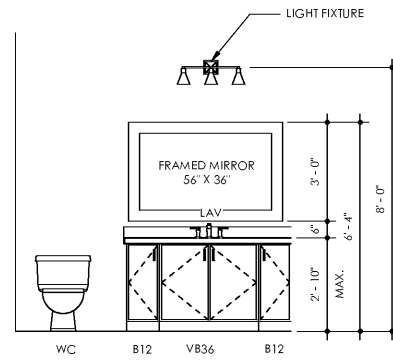

14 BATH
UNITS A4
SCALE: 3/8" = 1'-0"

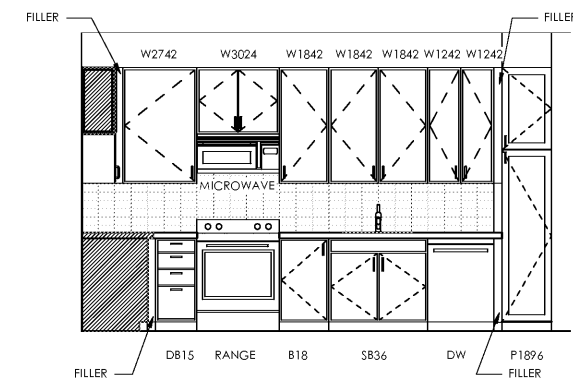

10 KITCHEN
UNITS A3, A3.1
SCALE: 3/8" = 1'-0"

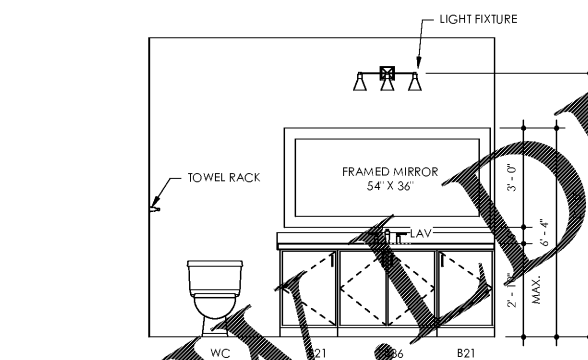

6 BATH
UNITS A1
SCALE: 3/8" = 1'-0"

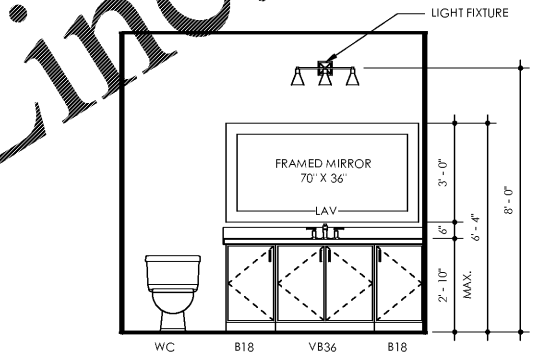

2 BATH
UNITS S1
SCALE: 3/8" = 1'-0"

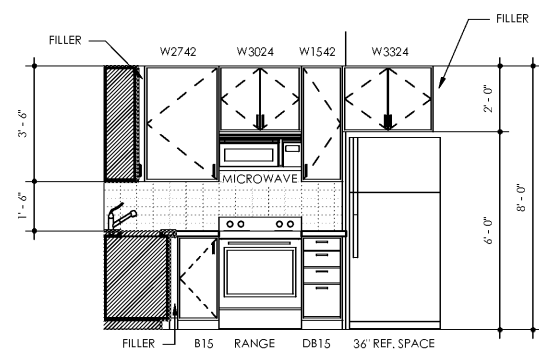

13 KITCHEN
UNITS A4
SCALE: 3/8" = 1'-0"

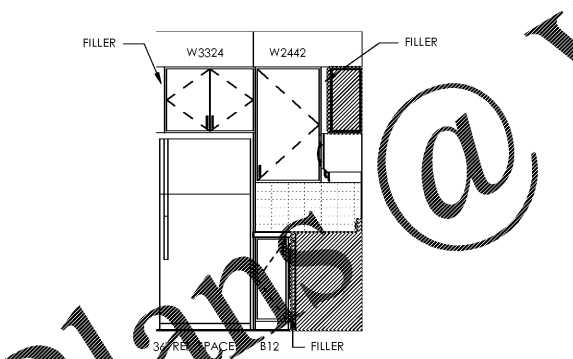

9 KITCHEN
UNITS A3, A3.1
SCALE: 3/8" = 1'-0"

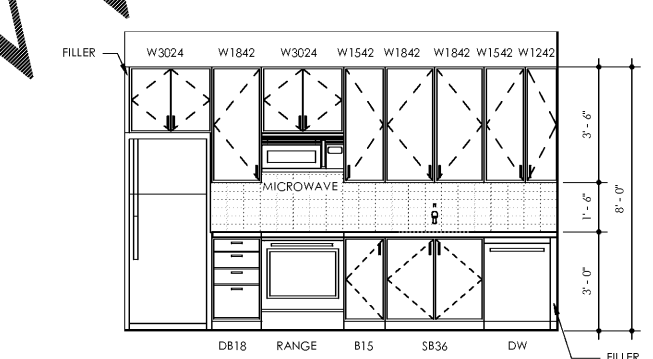

5 KITCHEN
UNITS A1
SCALE: 3/8" = 1'-0"

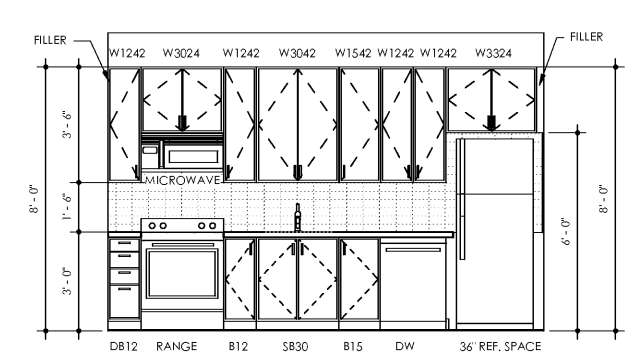

1 KITCHEN
UNITS S1
SCALE: 3/8" = 1'-0"

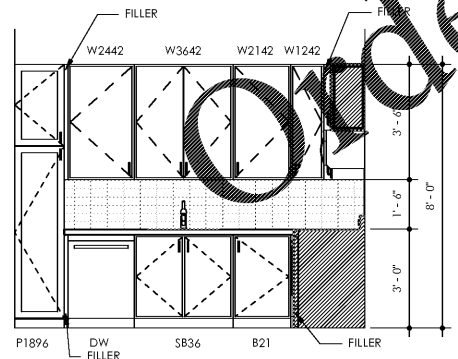

12 KITCHEN
UNITS A4
SCALE: 3/8" = 1'-0"

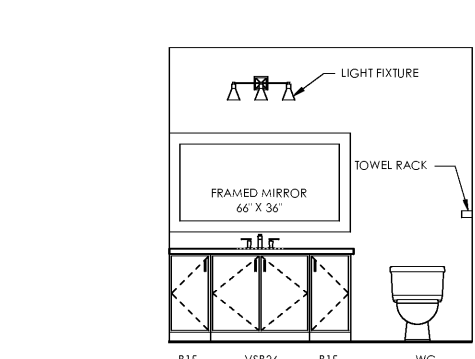

8 BATH
UNIT A2
SCALE: 3/8" = 1'-0"

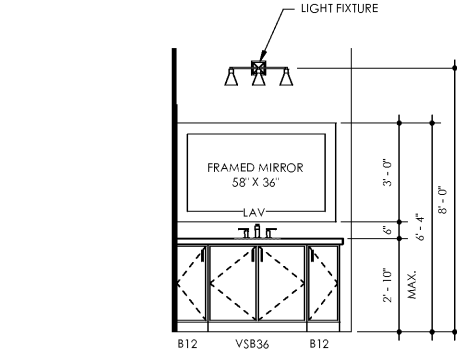

4 BATH
UNIT S2
SCALE: 3/8" = 1'-0"

- GENERAL NOTES**
1. ALL APPLIANCES WILL BE SILVER FINISH
 2. ALL ACCESSIBLE OVENS/RANGES TO HAVE FRONTAL CONTROLS.
 3. MAXIMUM FILLER SIZE = 3"
 4. MICROWAVES IN ACCESSIBLE UNITS TO BE AT COUNTER LEVEL.
 5. 50% MINIMUM OF CABINETRY SHELVES IN ACCESSIBLE UNITS TO BE WITHIN REACH RANGE (48" HIGH MAX)

date: 06/04/2019
job no: 3789.15
drawn by: EGR JAC, TQT
reviewed by: CBA
issue history:
Δ Date

Lyric at Norton Commons
Prospect, Kentucky
Bristol Development Group
381 Mallory Station Rd, Suite 204
Franklin, TN 37067

charlan • brock associates
architects • planners
1770 fennell street
maitland florida 32751-7208
407.660.8900 | f.407.875.9948
www.cbaarchitects.com

INTERIOR ELEVATIONS UNIT KITCHENS AND BATHS

A4.91

6/26/2019 2:17:42 AM C:\A\C\Custom\Revit\Projects\3789.15\REVIT\NORTON COMMONS_A4.91.dwg (s:\projects\3789.15\revit\3789.15.dwg) (s:\projects\3789.15\revit\3789.15.dwg)

