

Date:	06/04/19
Drawn by:	PC
Reviewed by:	RC/JW
Job Number:	21889.1
Revision:	Date:

GRILL DETAILS INDICATE DESIGN INTENT ONLY. ENCLOSURE MUST BE VENTED TO COMPLY WITH ALL REQUIRED BUILDING AND ANSI CODES. CONTRACTOR TO CONSULT DIRECTLY WITH THE MANUFACTURER FOR INSTALLATION INSTRUCTIONS AND SPECIFICATIONS.

NOTE:  
 -ALL CEDAR WOOD IS TO BE FINISHED WITH SIKKENS CETOL SRD, 1 COAT OF TRANSLUCENT STAIN #077 (CEDAR)  
 -CONTRACTOR TO PROVIDE MATERIAL AND FINISH SAMPLES FOR LANDSCAPE ARCHITECT REVIEW AND APPROVAL PRIOR TO FABRICATION  
 -SEE STRUCTURAL ENGINEER DRAWINGS FOR ALL STRUCTURAL DETAILING AND FURTHER INFORMATION  
 -ALL ATTACHMENT HARDWARE AND SCREWS TO BE STAINLESS STEEL  
 -SHOP DRAWINGS TO BE PROVIDED TO OWNER / LANDSCAPE ARCHITECT FOR REVIEW OF GRILL STATION PRIOR TO ALL FABRICATION  
 -PROVIDE HEAT TRACE FOR SINK WATER LINES (SEE M.E.P. DRAWINGS)

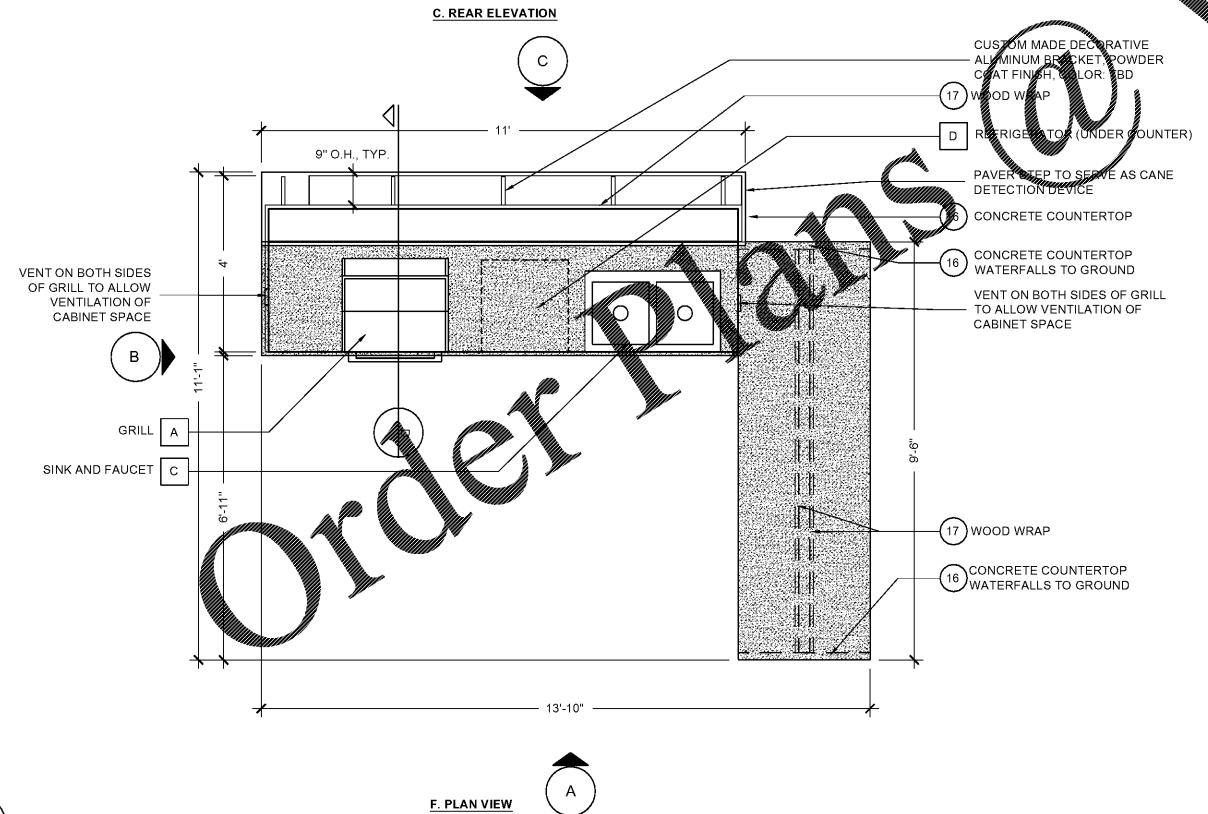
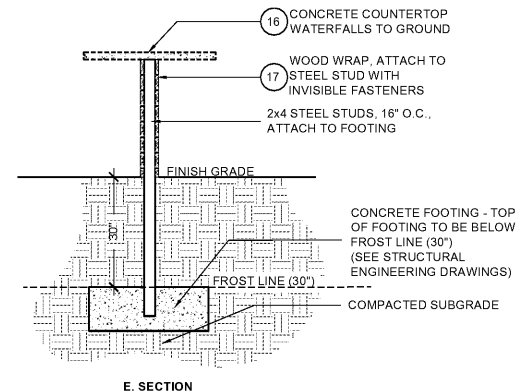
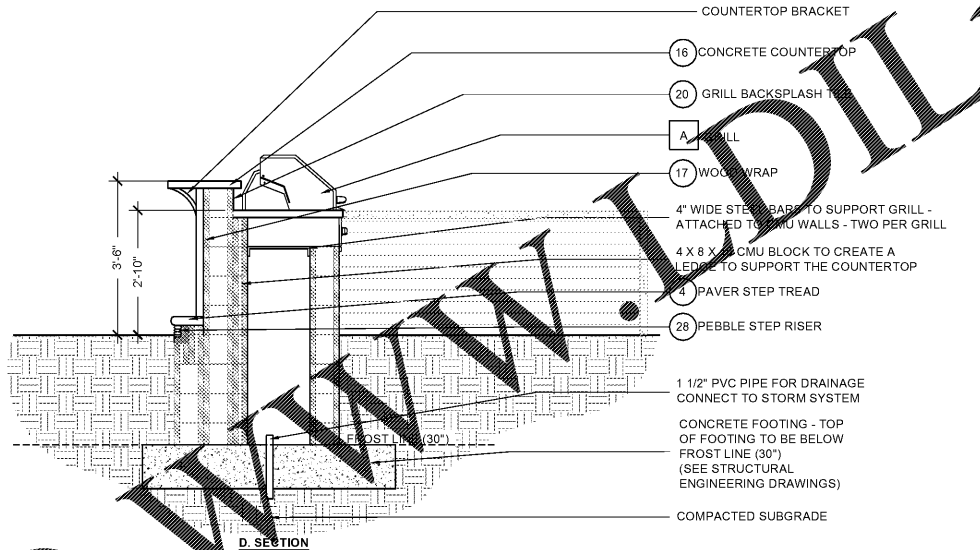
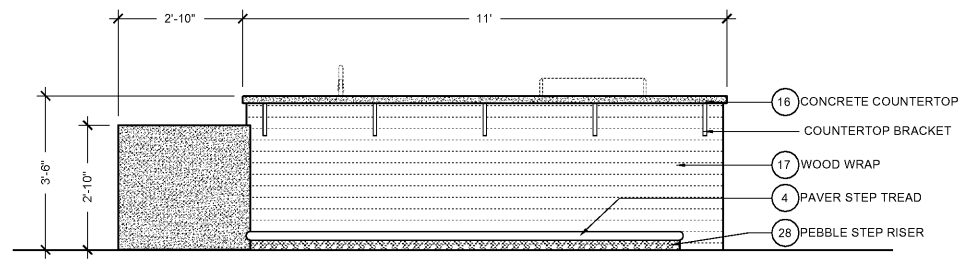
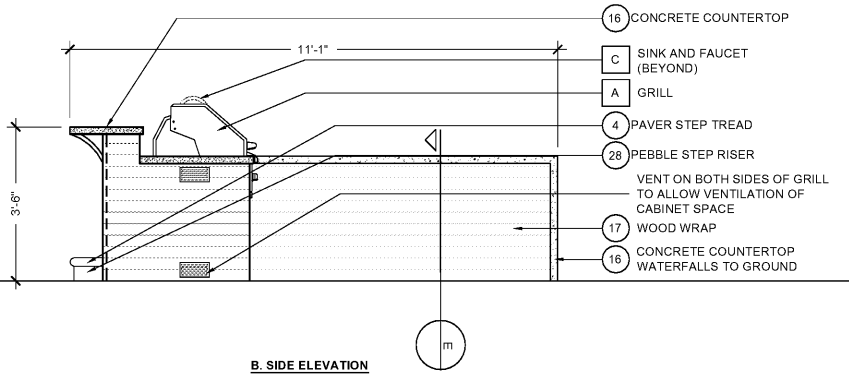
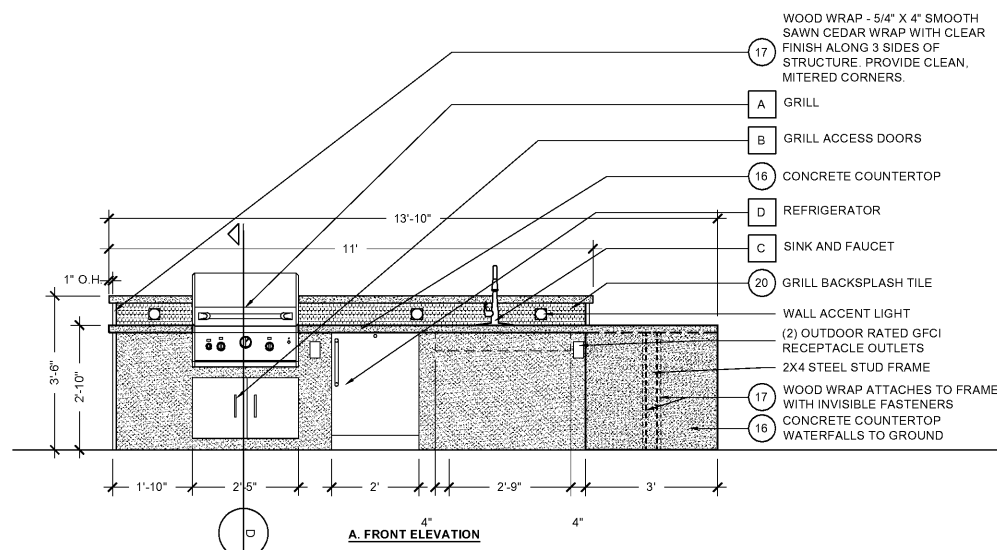

ITEM	QUANTITY	UNIT	DESCRIPTION
1	1	EA	GRILL
2	1	EA	REFRIGERATOR
3	1	EA	SINK AND FAUCET
4	1	EA	PAVER STEP TREAD
5	1	EA	PEBBLE STEP RISER
6	1	EA	WOOD WRAP
7	1	EA	CONCRETE COUNTERTOP
8	1	EA	GRILL BACKSPLASH TILE
9	1	EA	WALL ACCENT LIGHT
10	2	EA	OUTDOOR RATED GFCI RECEPTACLE OUTLETS
11	1	EA	2X4 STEEL STUD FRAME
12	1	EA	WOOD WRAP ATTACHES TO FRAME WITH INVISIBLE FASTENERS
13	1	EA	CONCRETE COUNTERTOP WATERFALLS TO GROUND
14	1	EA	CONCRETE COUNTERTOP WATERFALLS TO GROUND
15	1	EA	CONCRETE COUNTERTOP WATERFALLS TO GROUND
16	1	EA	CONCRETE COUNTERTOP WATERFALLS TO GROUND
17	1	EA	WOOD WRAP
18	1	EA	WOOD WRAP
19	1	EA	WOOD WRAP
20	1	EA	WOOD WRAP
21	1	EA	WOOD WRAP
22	1	EA	WOOD WRAP
23	1	EA	WOOD WRAP
24	1	EA	WOOD WRAP
25	1	EA	WOOD WRAP
26	1	EA	WOOD WRAP
27	1	EA	WOOD WRAP
28	1	EA	WOOD WRAP
29	1	EA	WOOD WRAP
30	1	EA	WOOD WRAP
31	1	EA	WOOD WRAP
32	1	EA	WOOD WRAP
33	1	EA	WOOD WRAP
34	1	EA	WOOD WRAP
35	1	EA	WOOD WRAP
36	1	EA	WOOD WRAP
37	1	EA	WOOD WRAP
38	1	EA	WOOD WRAP
39	1	EA	WOOD WRAP
40	1	EA	WOOD WRAP
41	1	EA	WOOD WRAP
42	1	EA	WOOD WRAP
43	1	EA	WOOD WRAP
44	1	EA	WOOD WRAP
45	1	EA	WOOD WRAP
46	1	EA	WOOD WRAP
47	1	EA	WOOD WRAP
48	1	EA	WOOD WRAP
49	1	EA	WOOD WRAP
50	1	EA	WOOD WRAP
51	1	EA	WOOD WRAP
52	1	EA	WOOD WRAP
53	1	EA	WOOD WRAP
54	1	EA	WOOD WRAP
55	1	EA	WOOD WRAP
56	1	EA	WOOD WRAP
57	1	EA	WOOD WRAP
58	1	EA	WOOD WRAP
59	1	EA	WOOD WRAP
60	1	EA	WOOD WRAP
61	1	EA	WOOD WRAP
62	1	EA	WOOD WRAP
63	1	EA	WOOD WRAP
64	1	EA	WOOD WRAP
65	1	EA	WOOD WRAP
66	1	EA	WOOD WRAP
67	1	EA	WOOD WRAP
68	1	EA	WOOD WRAP
69	1	EA	WOOD WRAP
70	1	EA	WOOD WRAP
71	1	EA	WOOD WRAP
72	1	EA	WOOD WRAP
73	1	EA	WOOD WRAP
74	1	EA	WOOD WRAP
75	1	EA	WOOD WRAP
76	1	EA	WOOD WRAP
77	1	EA	WOOD WRAP
78	1	EA	WOOD WRAP
79	1	EA	WOOD WRAP
80	1	EA	WOOD WRAP
81	1	EA	WOOD WRAP
82	1	EA	WOOD WRAP
83	1	EA	WOOD WRAP
84	1	EA	WOOD WRAP
85	1	EA	WOOD WRAP
86	1	EA	WOOD WRAP
87	1	EA	WOOD WRAP
88	1	EA	WOOD WRAP
89	1	EA	WOOD WRAP
90	1	EA	WOOD WRAP
91	1	EA	WOOD WRAP
92	1	EA	WOOD WRAP
93	1	EA	WOOD WRAP
94	1	EA	WOOD WRAP
95	1	EA	WOOD WRAP
96	1	EA	WOOD WRAP
97	1	EA	WOOD WRAP
98	1	EA	WOOD WRAP
99	1	EA	WOOD WRAP
100	1	EA	WOOD WRAP

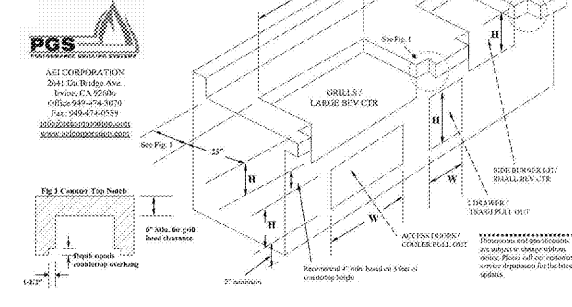

**SYMBOL LEGEND**

(B)	PLANTER POT SCHEDULE REFERENCE, SEE SHEET LA3.20
(1)	PAVING / MATERIALS SCHEDULE REFERENCE, SEE SHEET LA3.00
(A)	SITE FURNISHINGS SCHEDULE REFERENCE, SEE SHEET LA3.10

NOTE: ALL INFORMATION SHOWN IS FOR DESIGN INTENT / MATERIALITY PURPOSES ONLY. REFER TO CIVIL, STRUCTURAL, AND POOL ENGINEERING DRAWINGS FOR ADDITIONAL DETAILS.

**FABRICATION NOTES:**

- ALL DIMENSIONS TO BE FIELD VERIFIED PRIOR TO FABRICATION.
- CONTRACTOR TO SUBMIT SHOP DRAWINGS AND SAMPLES, INCLUDING FRAMING LAYOUT, TO LANDSCAPE ARCHITECT FOR REVIEW AND APPROVAL PRIOR TO FABRICATION.
- ALL COMPONENTS TO BE WELDED STRUCTURAL STEEL WITH NO MECHANICALLY FASTENED JOINTS UNLESS OTHERWISE NOTED.
- INFORMATION IS SHOWN FOR DESIGN INTENT PURPOSES ONLY. REFER TO CIVIL, STRUCTURAL AND POOL ENGINEERING DRAWINGS FOR ADDITIONAL SPECIFICATIONS, DETAILS AND MEMBER SIZING.

LYRIC AT NORTON COMMONS  
Prospect, Kentucky

Bristol Development Group  
380 Mallory Station Rd., #304, Franklin, TN 37064

DIX.HITE  
PARTNERS  
150 W. JESSUP AVENUE  
LONGWOOD, FLORIDA 32750  
TEL 407.667.1777

90% HARDSCAPE PLANS

GRILL DETAILS

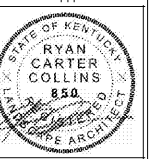

Sheet Number:  
**LA2.00**

01 GRILL 'A'  
LA2.00 SCALE: 1/2"=1'-0"

Order Plans @

WWW.DIXHITE.com