

14 HAND THERAPY - W
3/8" = 1'-0"

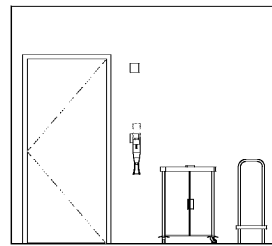

10 OT THERAPY TX RM - W
3/8" = 1'-0"

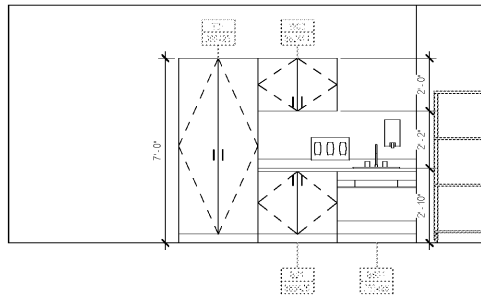

6 HYDROTHERAPY - S
3/8" = 1'-0"

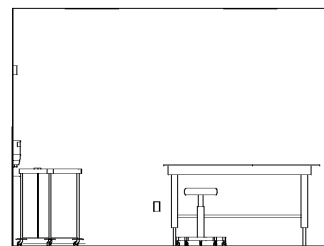

13 HAND THERAPY - S
3/8" = 1'-0"

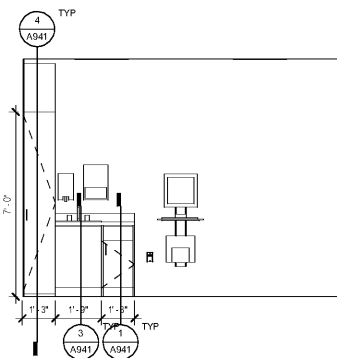

9 OT THERAPY TX RM - S
3/8" = 1'-0"

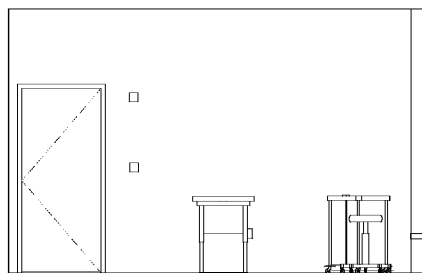

5 LYMPHEDEMA - S
3/8" = 1'-0"

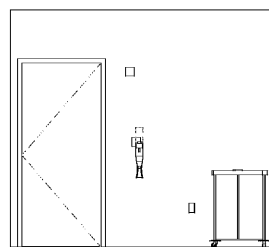

12 HAND THERAPY - E
3/8" = 1'-0"

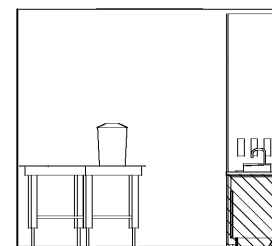

8 OT THERAPY TX RM - E
3/8" = 1'-0"

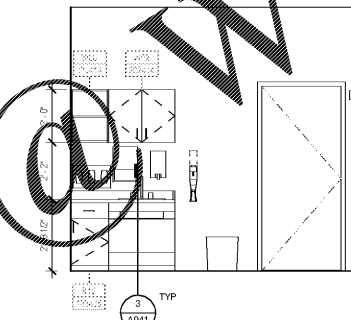

4 LYMPHEDEMA - E
3/8" = 1'-0"

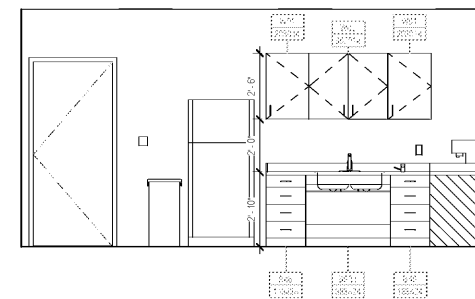

2 TPL ADL KITCHEN - S
3/8" = 1'-0"

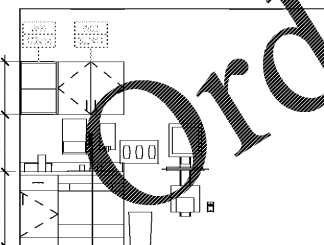

11 HAND THERAPY - N
3/8" = 1'-0"

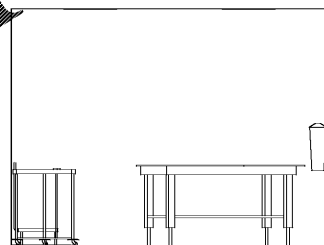

7 OT THERAPY TX RM - N
3/8" = 1'-0"

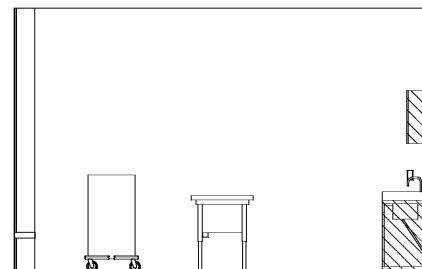

3 LYMPHEDEMA - N
3/8" = 1'-0"

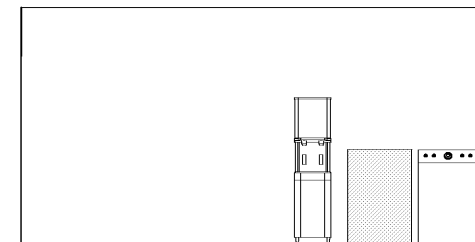

1 TYP ADL KITCHEN - N
3/8" = 1'-0"

SHEET SPECIFIC NOTES

- A. GENERAL NOTES:
1. TRUE NORTH USED FOR NORTH, EAST, SOUTH, AND WEST DESIGNATIONS. REFER TO NORTH ARROW ON FLOOR PLANS.
 2. EQUIPMENT IS SHOWN FOR SPACE PLANNING AND MOUNTING-HEIGHT PURPOSES ONLY. REFER TO MEDICAL EQUIPMENT DRAWINGS FOR QUANTITIES, DIMENSIONS, POWER REQUIREMENTS AND ADDITIONAL INFORMATION.
 3. ALL CASEWORK TO BE LOCKABLE, U.A.D.
 4. REFER TO ENLARGED PLANS, ELEVATIONS AND DETAILS FOR CLARIFICATION OF EXTENT OF FINISH MATERIALS AND ADDITIONAL INFORMATION.
 5. REFER TO A400 SERIES SHEETS FOR TYPICAL CASEWORK SECTIONS AND GENERAL NOTES.
 6. REFER TO A220 SERIES FINISH PLANS FOR FINISH & WALL PROTECTION SYSTEM EXTENTS AND INFORMATION.
 7. REFER TO A220.1, A220.2 FOR WALL PROTECTION SYSTEM LEGEND TO FINISH SCHEDULE.
 8. WHERE TRANSITIONS OF WALL PROTECTION OCCUR USE PLY REGLET TRANSITIONS PIECES AS FOLLOWS:
 - A. AT CORNER TRANSITIONS USE REGLET TP-125-217 CLEAR ANODIZED.
 - B. AT TRANSITION FROM WALL PROTECTION TO CASE, USE PLY REGLET WCTS TP-125-217 CLEAR ANODIZED.
 - C. AT TRANSITION FROM TRANSITION TO WALL PROTECTION USE WCTS TP-125-217 CLEAR ANODIZED.
 9. DETAILS:
 1. GIBB - GYPSPR WALL BOARD
 2. WALL PROTECTION SYSTEM.



Project
THE CENTER FOR
ADVANCED SURGICAL
SERVICES (CASS)
80 GILMER STREET SE
ATLANTA, GA 30303

Prepared For
GRADY HEALTH SYSTEM
80 JESSE HILL DR. SE
ATLANTA, GA 30303



Hok
Helmut, Obata & Kassabaum, Inc.
133 Peachtree Street, NE, Suite 4800
Atlanta, GA 30303 USA
1+1 404 439 9000 1+1 404 439 9001

All reproduction & intellectual property rights reserved ©
2019
In Association with

Key Plan

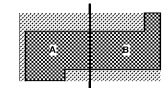

Professional Seal

NOT FOR
CONSTRUCTION

No.	Description	Date
1	DC - GMP	2019-07-03

Project No: 18.16013.00
Sheet Title

CLINICAL ELEVATIONS
- LEVEL 07

Original is 20 x 43. Do not scale contents of this drawing
Sheet Number

A647.0