

**StormTrap**  
1327 WINSTON PARKWAY  
 BUNNELLVILLE, GA 30428  
 PHONE: 911-4549 / 770-311-2100 FAX: 770-311-2247

**ENGINEER INFORMATION:**  
 EBERLY & ASSOCIATES  
 2951 FLOWERS RD S  
 SUITE 119  
 ATLANTA, GA  
 770-452-7849

**PROJECT INFORMATION:**  
 GRADY CASS  
 NORTH BASIN 1  
 ATLANTA, GA

**CURRENT ISSUE DATE:**  
 5/23/2019

**ISSUED FOR:**  
 PRELIMINARY

**REV. DATE: ISSUED FOR: DRAWN BY:**

**SCALE:**  
 AS SHOWN

**SHEET TITLE:**  
 DOUBLETRAP INSTALLATION SPECIFICATIONS

**SHEET NUMBER:**  
**3.1**

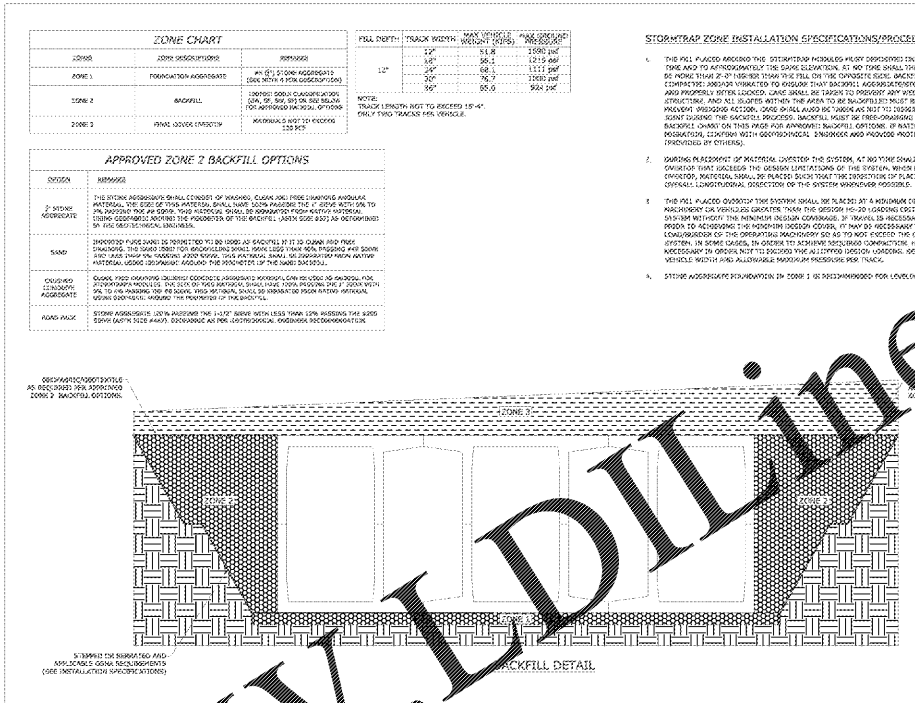

**StormTrap**  
1327 WINSTON PARKWAY  
 BUNNELLVILLE, GA 30428  
 PHONE: 911-4549 / 770-311-2100 FAX: 770-311-2247

**ENGINEER INFORMATION:**  
 EBERLY & ASSOCIATES  
 2951 FLOWERS RD S  
 SUITE 119  
 ATLANTA, GA  
 770-452-7849

**PROJECT INFORMATION:**  
 GRADY CASS  
 NORTH BASIN 1  
 ATLANTA, GA

**CURRENT ISSUE DATE:**  
 5/23/2019

**ISSUED FOR:**  
 PRELIMINARY

**REV. DATE: ISSUED FOR: DRAWN BY:**

**SCALE:**  
 AS SHOWN

**SHEET TITLE:**  
 DOUBLETRAP BACKFILL SPECIFICATIONS

**SHEET NUMBER:**  
**4.0**

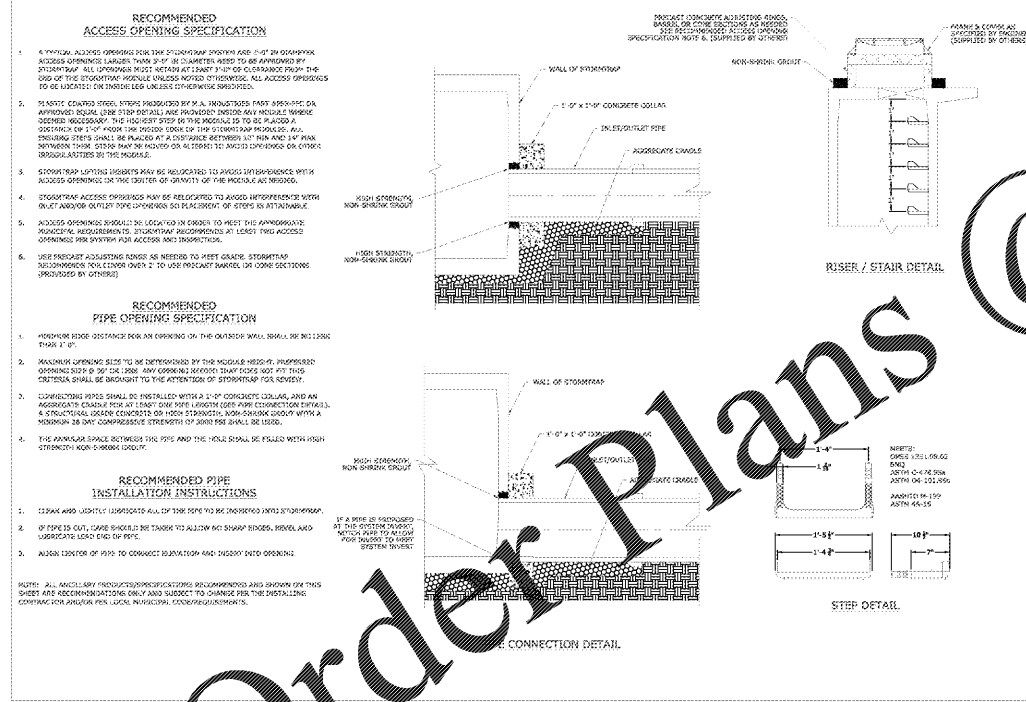

**StormTrap**  
1327 WINSTON PARKWAY  
 BUNNELLVILLE, GA 30428  
 PHONE: 911-4549 / 770-311-2100 FAX: 770-311-2247

**ENGINEER INFORMATION:**  
 EBERLY & ASSOCIATES  
 2951 FLOWERS RD S  
 SUITE 119  
 ATLANTA, GA  
 770-452-7849

**PROJECT INFORMATION:**  
 GRADY CASS  
 NORTH BASIN 1  
 ATLANTA, GA

**CURRENT ISSUE DATE:**  
 5/23/2019

**ISSUED FOR:**  
 PRELIMINARY

**REV. DATE: ISSUED FOR: DRAWN BY:**

**SCALE:**  
 AS SHOWN

**SHEET TITLE:**  
 RECOMMENDED PIPE / ACCESS OPENING SPECIFICATIONS

**SHEET NUMBER:**  
**5.0**

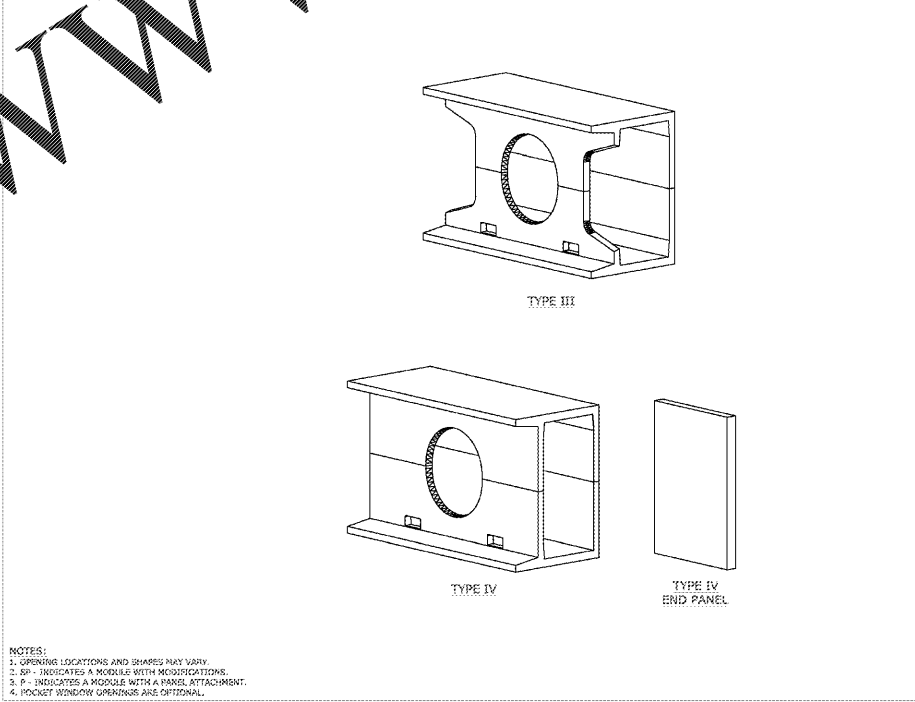

**StormTrap**  
1327 WINSTON PARKWAY  
 BUNNELLVILLE, GA 30428  
 PHONE: 911-4549 / 770-311-2100 FAX: 770-311-2247

**ENGINEER INFORMATION:**  
 EBERLY & ASSOCIATES  
 2951 FLOWERS RD S  
 SUITE 119  
 ATLANTA, GA  
 770-452-7849

**PROJECT INFORMATION:**  
 GRADY CASS  
 NORTH BASIN 1  
 ATLANTA, GA

**CURRENT ISSUE DATE:**  
 5/23/2019

**ISSUED FOR:**  
 PRELIMINARY

**REV. DATE: ISSUED FOR: DRAWN BY:**

**SCALE:**  
 AS SHOWN

**SHEET TITLE:**  
 DOUBLETRAP MODULE TYPES

**SHEET NUMBER:**  
**6.0**

Project  
**THE CENTER FOR ADVANCED SURGICAL SERVICES (CASS)**  
 80 GILMER STREET SE  
 ATLANTA, GA 30303

Prepared For  
**GRADY HEALTH SYSTEM**  
 80 JESSE HILL DR. SE  
 ATLANTA, GA 30303

**h+k**  
 Hellmuth, Obata & Kassabaum, Inc.  
 133 Peachtree Street, NE, Suite 4800  
 Atlanta, GA 30303 USA  
 t+1 404 439 9000 f+1 404 439 9001

All reproduction & intellectual property rights reserved © 2019  
 In Association with

Eberly & Associates, Inc.  
 CIVIL ENGINEERING  
 2951 Flowers Road South, Suite 119  
 Atlanta, GA 30341

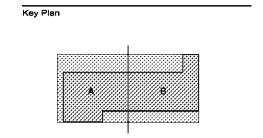

**NOT FOR CONSTRUCTION**

No.	Description	Date
1	DD - GMP	2019-07-01

Project No: **18-16013.00**  
 Sheet Title  
**CONSTRUCTION DETAILS**