

4 GR - DOUBLE QUEEN_powerplan
3/8" = 1'-0"

5 GR - DOUBLE QUEEN_FINPLAN
3/8" = 1'-0"

3 GR - DQ RCP
3/8" = 1'-0"

2 GR - DOUBLE QUEEN
3/8" = 1'-0"

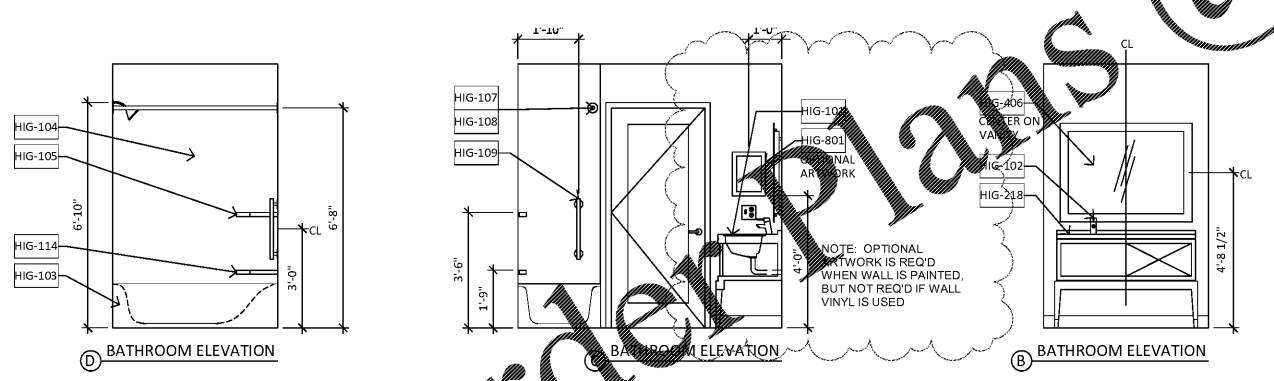

D BATHROOM ELEVATION

B BATHROOM ELEVATION

B BATHROOM ELEVATION

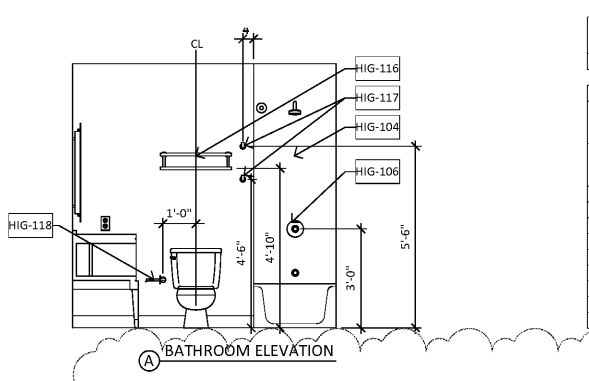

A BATHROOM ELEVATION

GUESTROOM - GENERAL NOTES	
NOTE	
1	PATCH AND REPAIR ALL EXISTING PARTITIONS, DOORS, AND FRAMES. MATCH EXISTING CONSTRUCTION UNO
2	PROVIDE BACKING SUPPORT FOR ALL WALL-MOUNTED CABINETS AND WALL-HUNG FURNITURE UNITS. COORDINATE LOCATIONS AND BACKING SUPPORT MOUNTING HEIGHTS WITH CASEWORK SUBCONTRACTOR AND FURNITURE MANUFACTURER PRIOR TO CONSTRUCTION
3	ALL POWER AND COMMUNICATION RECEPTACLES SHOWN ON PLAN ARE EXISTING BASED ON THE CURRENT PROTOTYPE. UNO. THE ARCHITECT OF RECORD SHALL UPDATE RECEPTACLE LOCATIONS BASED ON THE SPECIFIC PROPERTY AND COORDINATE AS REQUIRED
4	REFER TO ELEVATIONS FOR SCONCE AND MIRROR MOUNTING HEIGHTS
5	ALL MOUNTING HEIGHTS ARE FROM FINISH FLOOR TO CENTER OF PLATE, UNO
6	ALL RECEPTACLES SHOWN IN ELEVATION ARE FOR CLARIFICATION AND COORDINATION WITH FF&E
7	THE FINISH PLAN SHOULD BE USED IN CONJUNCTION WITH THE SET OF CONSTRUCTION DRAWINGS AND WRITTEN SPECIFICATIONS
8	ALL FLOORING TO BE INSTALLED IN ACCORDANCE WITH MANUFACTURER'S RECOMMENDATIONS FOR INSTALLATION. UNO
9	PAINT WALLS PT01 UNO
10	PAINT DOORS AND FRAMES TO MATCH ADJACENT WALL UNO
11	PAINT GUESTROOM ENTRY DOOR FRAME PT05
12	VERIFY OUTLET ROUGH-IN LOCATION W/ OWNER & IHG

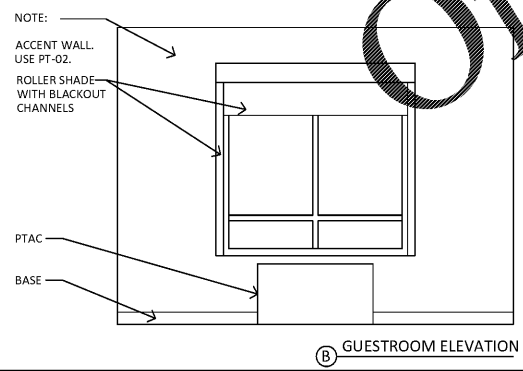

B GUESTROOM ELEVATION

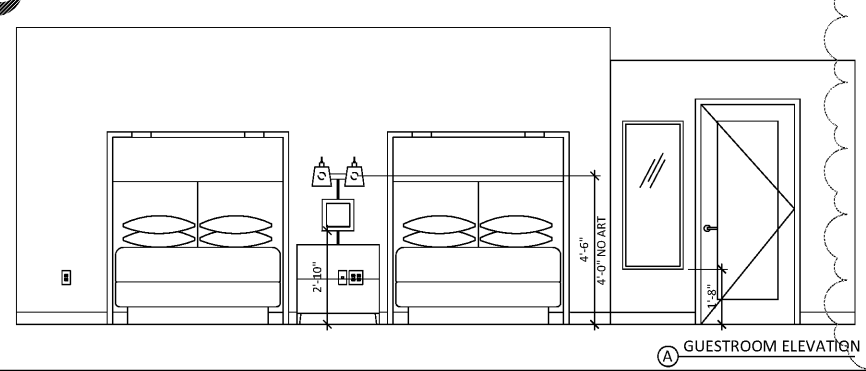

A GUESTROOM ELEVATION

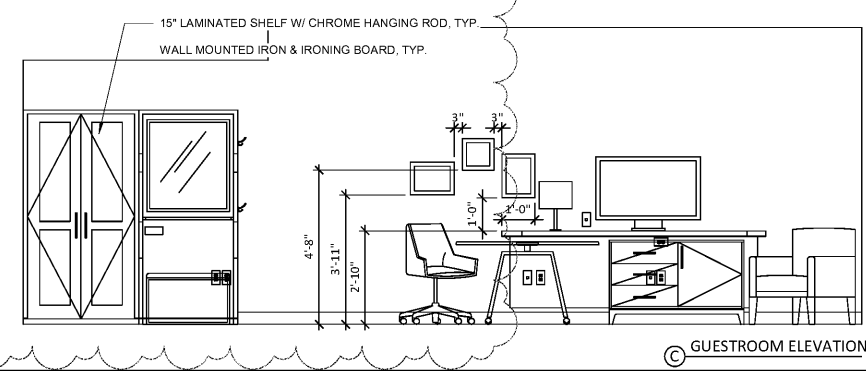

C GUESTROOM ELEVATION

THESE DRAWINGS ARE PRELIMINARY IN NATURE AND INTENDED FOR REVIEW AND PERMITTING. DRAWINGS ARE NOT TO BE USED FOR CONSTRUCTION WITHOUT ARCHITECT'S AND ENGINEER'S SIGNATURE AND THEIR DATE OF ISSUE FOR CONSTRUCTION.

RECORD

JSA ARCHITECTS
 9726 E. 42nd St. SUITE 153
 TULSA, OK 74146
 918.640.6800
 JHNSANFORD@AOL.COM

Copyright 2019 John Sanford
 JOHN SANFORD,
 AIA, NCARB
 TN LICENSE #106056

4/4/2019
 2:04:01 PM

John Sanford

NOT VALID FOR CONSTRUCTION UNLESS SIGNED IN THIS BLOCK

PROPOSED HOLIDAY INN LI 9383
 215 CRACKER BARREL DR., CLARKSVILLE
 MONTGOMERY COUNTY, TENNESSEE

PERMIT NO:

4/4/2019
 2:04:01 PM

No.	Description	Date
A	IHG Review	2.20.19

SHEET

A412
 DOUBLE QUEEN