

1 TYPICAL DECK PARALLEL TO EDGE BEAM (w/ JOISTS)  
S01-02

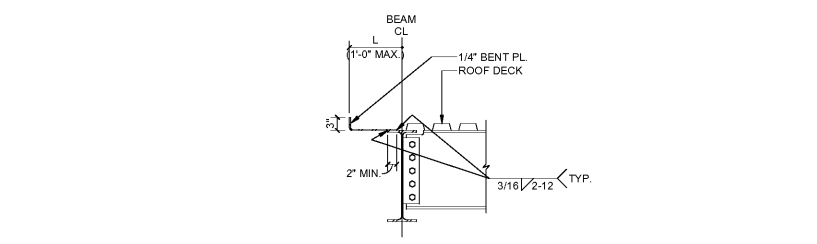

2 TYPICAL DECK PARALLEL TO EDGE BEAM (NO JOISTS)  
S01-02

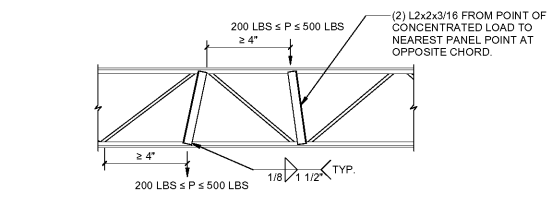

3 TYPICAL STEEL JOIST REINF. FOR CONCENTRATED LOADS  
S01-02

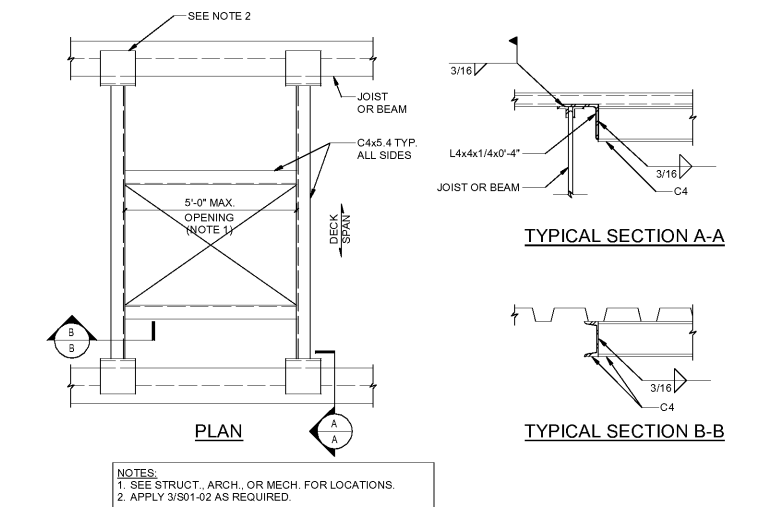

4 TYPICAL FRAMED ROOF OPENING  
S01-02

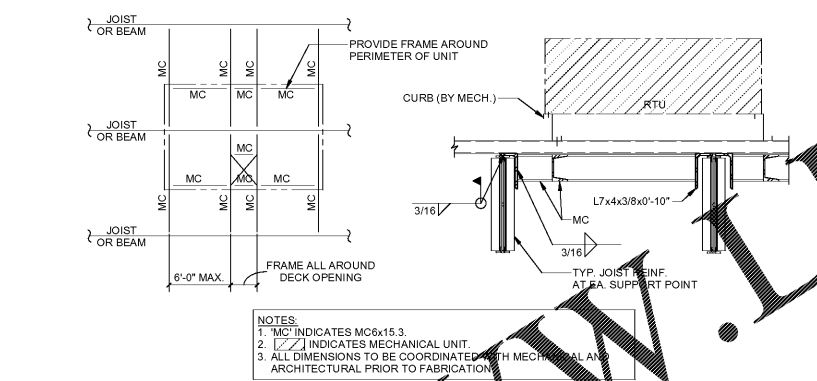

5 TYPICAL RTU FRAME  
S01-02

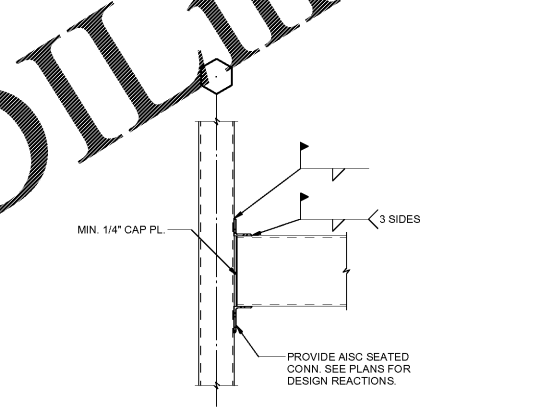

6 TYPICAL HSS BEAM TO COLUMN CONNECTION  
S01-02

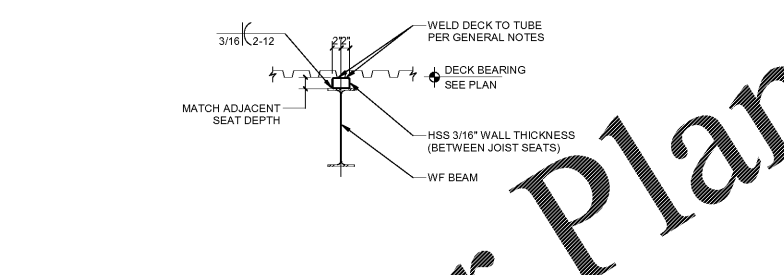

7 TYPICAL SECTION AT DRAG STREET  
S01-02

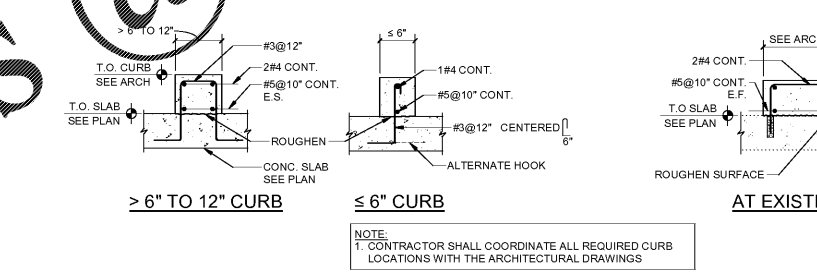

8 TYPICAL SECTION THROUGH CONCRETE CURB  
S01-02

Order Plans @ WWW.LDILine.com

DATE	ISSUE	DATE
18220	ZZ	
SG		
JH		

TYPICAL DETAILS

SHEET NUMBER

**S01-02**