

ACCESSIBLE PARKING REQUIREMENTS

TOTAL PARKING SPACES PROVIDED	MINIMUM NUMBER OF ACCESSIBLE SPACES REQUIRED	MINIMUM NUMBER OF ACCESSIBLE SPACES REQUIRED TO BE VAN ACCESSIBLE
1 TO 25	1	1
26 TO 50	2	1
51 TO 75	3	1
76 TO 100	4	1
101 TO 150	5	1
151 TO 200	6	1
201 TO 300	7	1
301 TO 400	8	1
401 TO 500	9	2
501 TO 1000	2% OF TOTAL	1 IN EVERY 8 ACCESSIBLE SPACES
1001 AND OVER	2% PLUS 1 FOR EACH 100 OVER 1000	1 IN EVERY 8 ACCESSIBLE SPACES

SECTION 4.1.2 (5) OF THE AMERICANS WITH DISABILITIES ACT (ADA), SEE 4.1.2(5) (6) FOR MEDICAL CARE FACILITIES

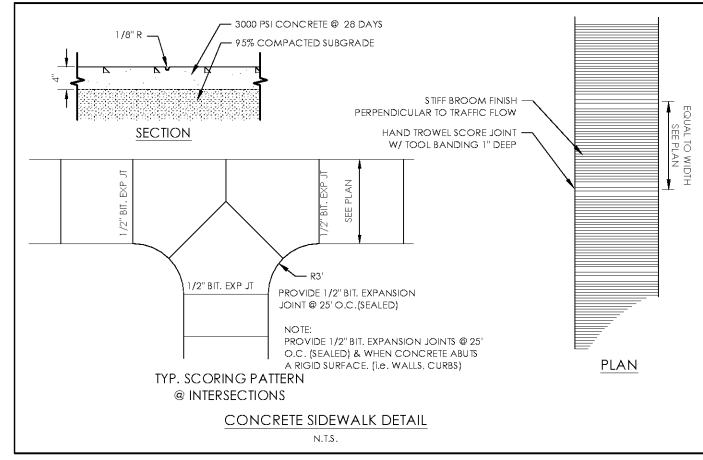
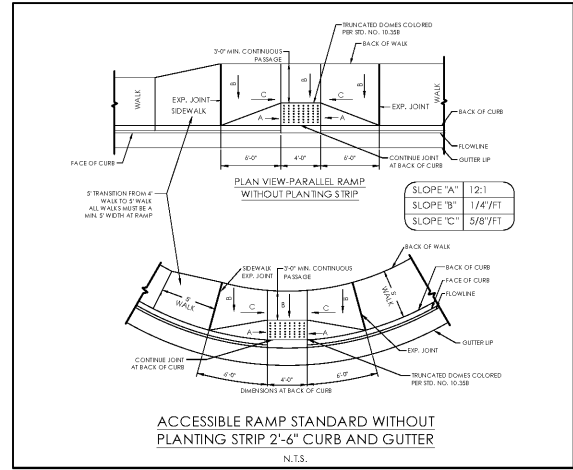
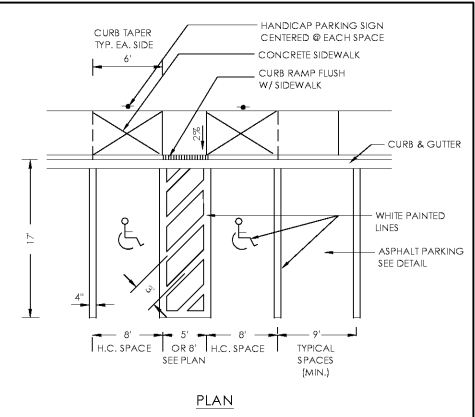

- NOTES:**
- ALL 12x18" ACCESSIBLE SIGNS (RP-80 & RP-11) SHALL BE MOUNTED AT 7 FEET FROM MOUNTING HEIGHT CAN BE REDUCED TO GRADE TO BOTTOM EDGE OF SIGN FACE (MUTCD 5.9) IF PLACED IN AN AREA BETWEEN SIDEWALK AND BUILDING FACE IN WHICH PEDESTRIANS ARE NOT EXPECTED TO USE.
 - REFER TO MANUAL ON UNIFORM TRAFFIC CONTROL DEVICES (MUTCD) U.S. DEPARTMENT OF TRANSPORTATION AND CITY / COUNTY / STATE DEPARTMENT OF TRANSPORTATION SUPPLEMENTS.
 - IF ACCESSIBLE ROUTE IS A RAISED SIDEWALK AREA, THEN RAMPS ARE REQUIRED AT LOADING ZONE AREA.

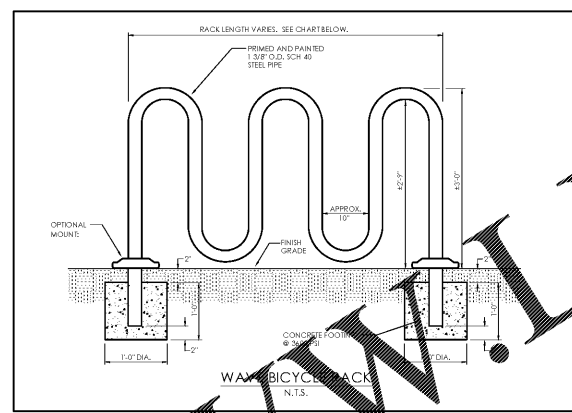
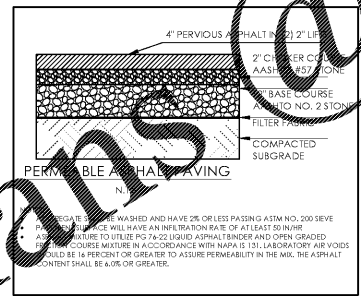
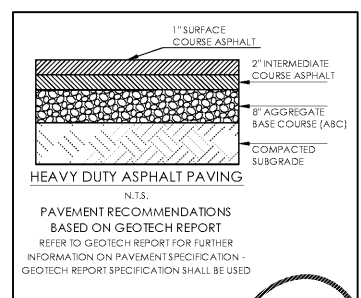
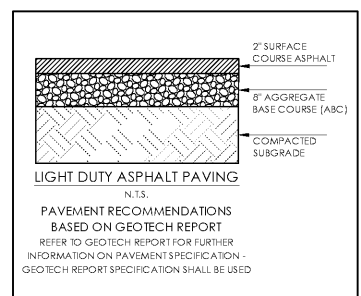
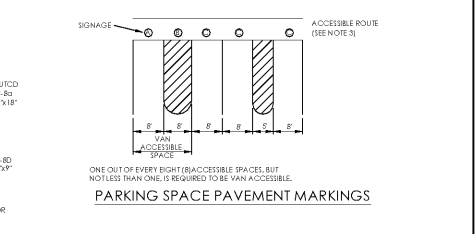
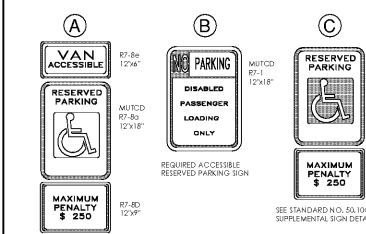

Order Plans @ WWW.LDILine.com

- CALL ULOCO BEFORE YOU DIG
-
- CONTRACTOR IS FULLY RESPONSIBLE FOR CONTACTING APPROPRIATE PARTIES AND ASSURING THAT EXISTING UTILITIES ARE LOCATED PRIOR TO BEGINNING CONSTRUCTION.
 - CONTRACTOR IS RESPONSIBLE FOR PLACING BARRICADES USING FLAGMEN ETC., AS NECESSARY TO INSURE SAFETY TO THE PUBLIC.
 - ALL PAVEMENT CUTS, CONCRETE OR ASPHALT ARE TO BE REPLACED ACCORDING TO STANDARDS OF THE NORTH CAROLINA DEPARTMENT OF TRANSPORTATION.
 - SHORING WILL BE ACCORDING TO OSHA TRENCHING STANDARDS PART 1926 SUBPART P, OR AS AMENDED.
- 1-800-652-4949
AVOID UTILITY DAMAGE

HensonFoley
Landscape Architecture | Civil Engineering | Surveying
8712 Lindholm Dr Suite 202A, Huntersville, NC 28078
P: 704.875.1615 | www.hensonfoley.com
NC ARCHITECTURE BOARD LICENSE # C-378
NC ENGINEERING BOARD LICENSE # E-399
NC LAND SURVEYING BOARD LICENSE # L-386

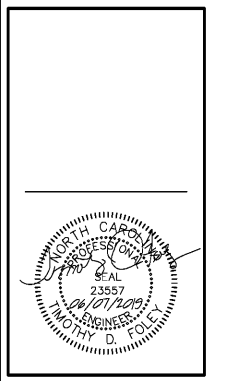

HOME2 SUITES BELMONT
3595444233, 35954443246, 3595442340, 3595441343, 3595440335
HAWLEY AVE, BELMONT, NORTH CAROLINA 28012

PROJECT DETAILS

REVISIONS:

REV1 - ISSUE FOR BID 2019-06-07

C10 - DETAILS.DWG
PROJECT NUMBER: 217090
DATE: 03/12/2019 DRAWN BY: JDC
C10 OF 15 SHEET