

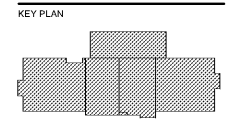

HOME 2 SUITES BELMONT
HAWLEY AVE
BELMONT, NC 28012



Revisions		
#	Date	Description

Project Number: 18021
Issued for: CONSTRUCTION
Issue Date: 2019-06-07

DRAWING TITLE
CASEWORK - MEETING ROOM

SHEET NUMBER
ID.479

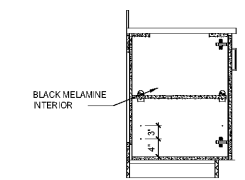

- NOTES:**
- ALL EXPOSED CABINET SURFACES PLUS LAMINATE PER SPECIFICATIONS WITH 1/8" EDGE BAND TO MATCH
 - BLACK MELAMINE CONCEALED CAB SURFACES
 - FILLERS TO BE USED TO COMPLETE BASED ON FIELD DIMENSIONS

13K SECTION
SCALE: 1/4" = 1'-0"

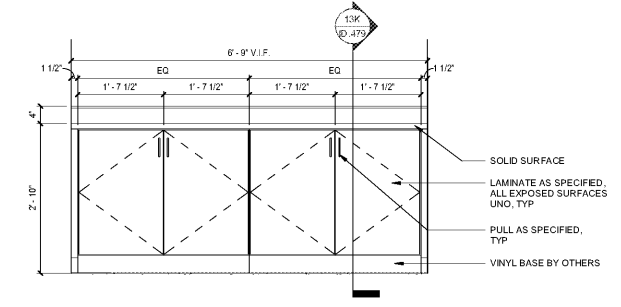

13E ELEVATION
SCALE: 3/4" = 1'-0"

SPECIFICATIONS:
REFER TO FF&E SPECIFICATIONS F-309 FOR BALANCE OF INFORMATION

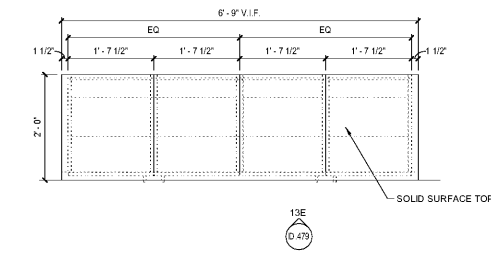

13A PLAN - BOARD ROOM
SCALE: 3/4" = 1'-0"

Order Plans @ www.LDILine.com