

PHILLIPS
architects + engineers

770.394.1616

CONSULTANT

SEAL

ISSUE & REVISION RECORD

#	DATE	DESCRIPTION
1	05/30/2019	PERMIT SUBMITTAL

TENANT

PROJECT

THE PROMENADE

D'BERVILLE, MS.

CLIENT

CBL
CBL PROPERTIES

136 Conroy Ave. #1000, Dunwoody, GA 30328-4000, Tel: 770-400-5000, Fax: 770-400-5001, www.cblproperties.com

PHILLIPS JOB NUMBER: 1925401

ISSUE DATE: 05/30/2019

DRAWN BY/CHECKED BY: MT/GC

DRAWING TITLE: TYPICAL DETAILS

SHEET NUMBER

A-9.2

THE PALISADES
5901 PEACHTREE DUNWOODY RD.
BUILDING A, SUITE 450
ATLANTA, GEORGIA 30328

NOTE:
ALL COMPONENTS OF THE ROOF ASSEMBLIES INVOLVING THE ROOF DECK AND ALL COVERINGS ABOVE THE ROOF SHALL HAVE THE FM APPROVAL STAMP, CONFORM TO THE 2018 IBC HIGH-VELOCITY HURRICANE ZONES, AND BE INSTALLED PER PRODUCT APPROVAL TESTED ASSEMBLY

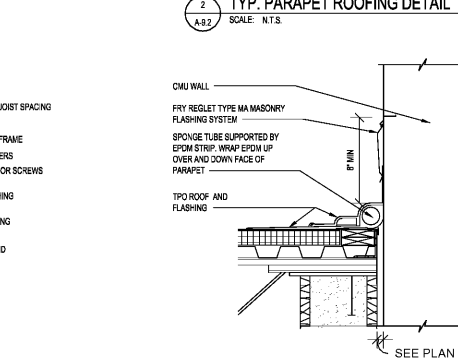
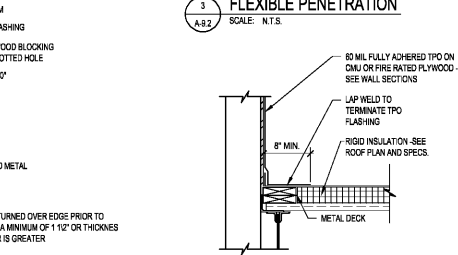
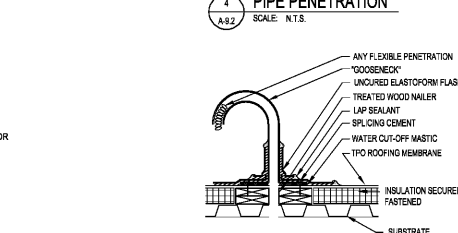
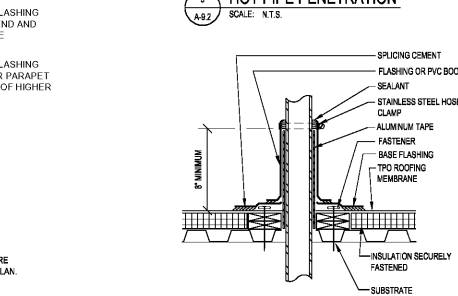
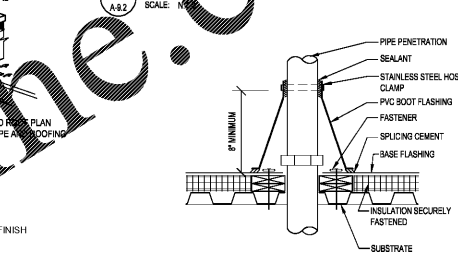
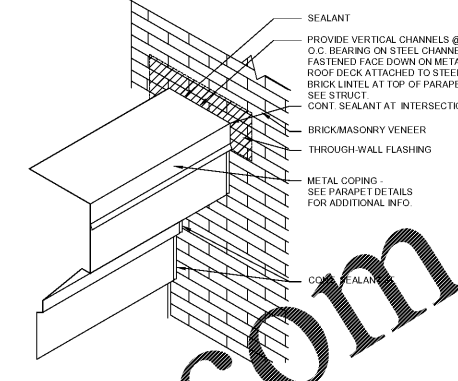
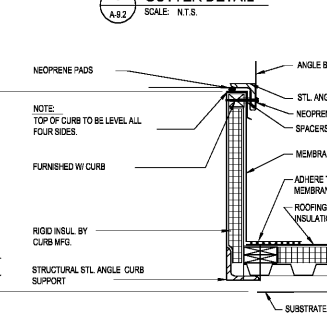
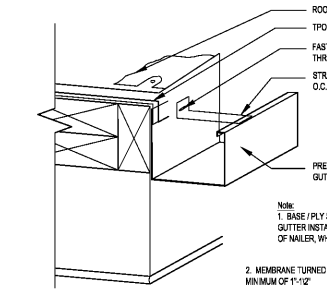
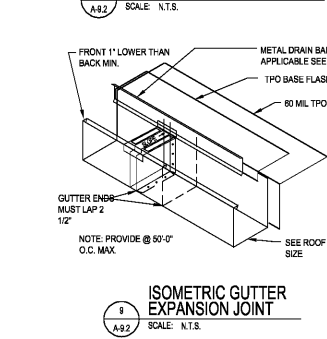
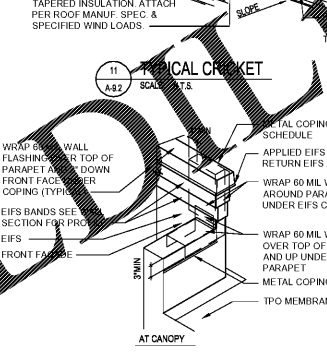
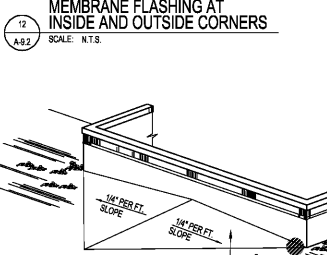
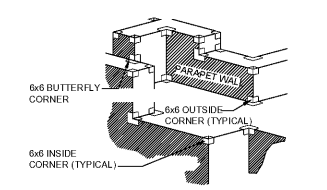
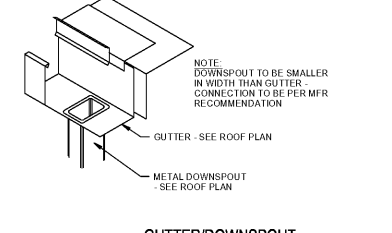
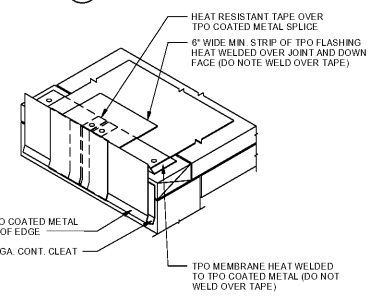
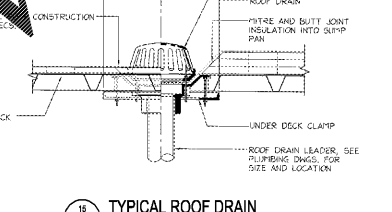
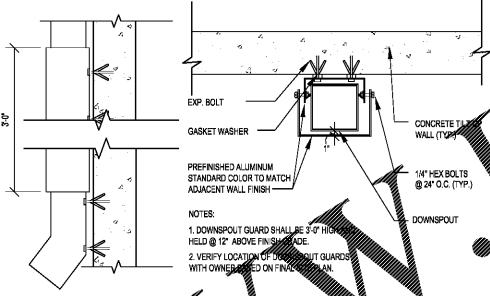
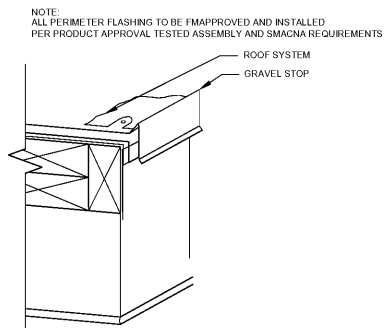
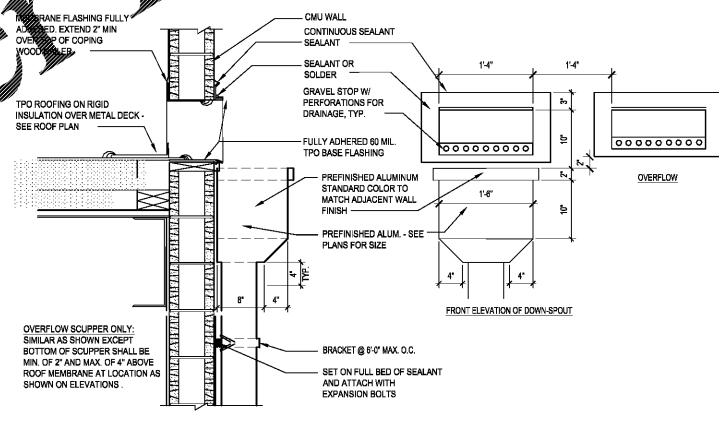
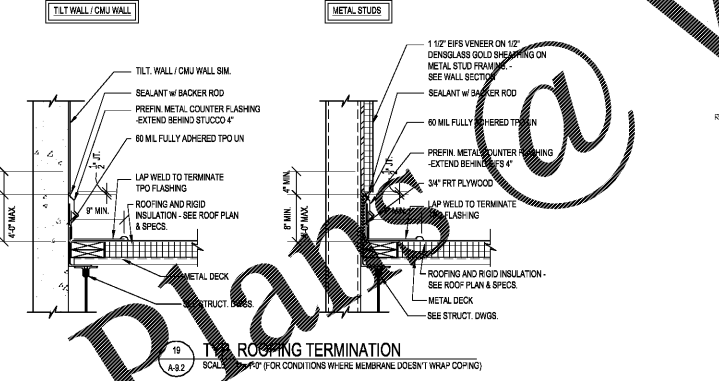
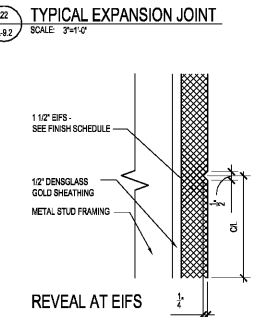
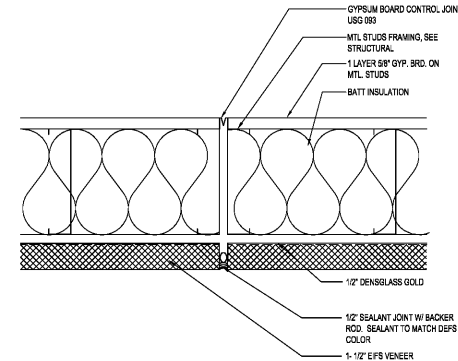
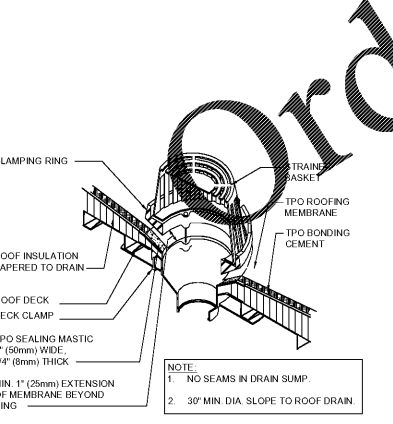
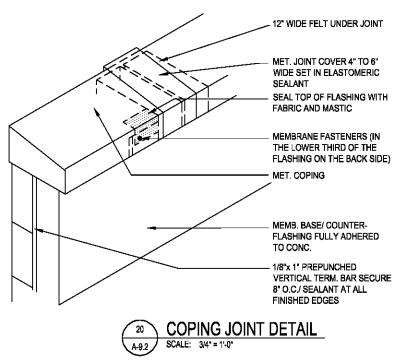
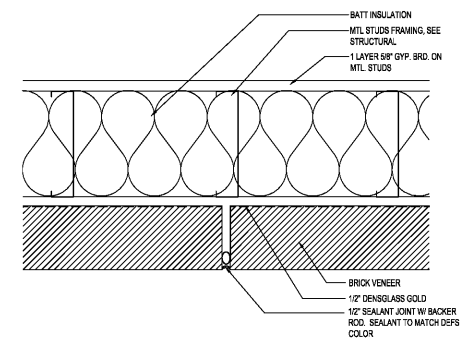
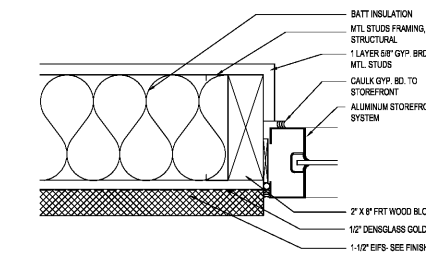
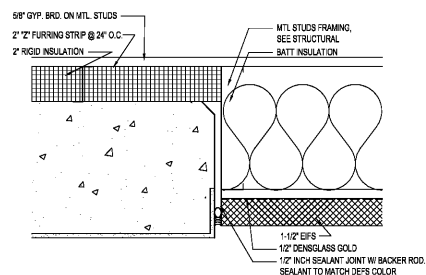

Order Plans @