

01 | 1002 & 1003- MEETING ROOMS A & B

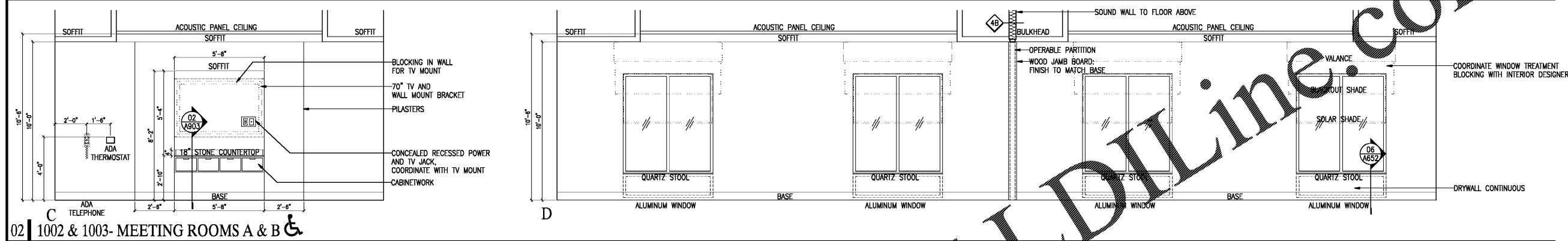

02 | 1002 & 1003- MEETING ROOMS A & B

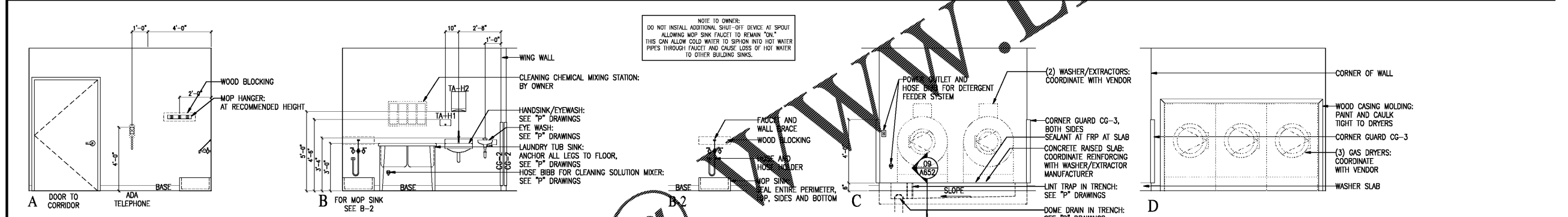

03 | 1008- LAUNDRY [ALL WALLS FRP]

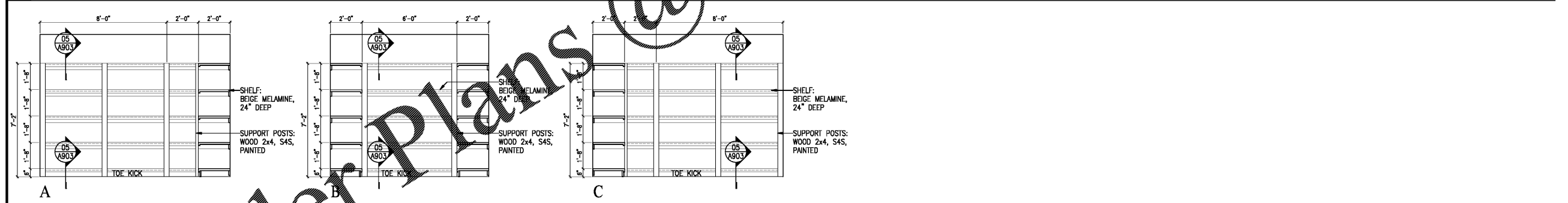

04 | 1009- LAUNDRY STORAGE

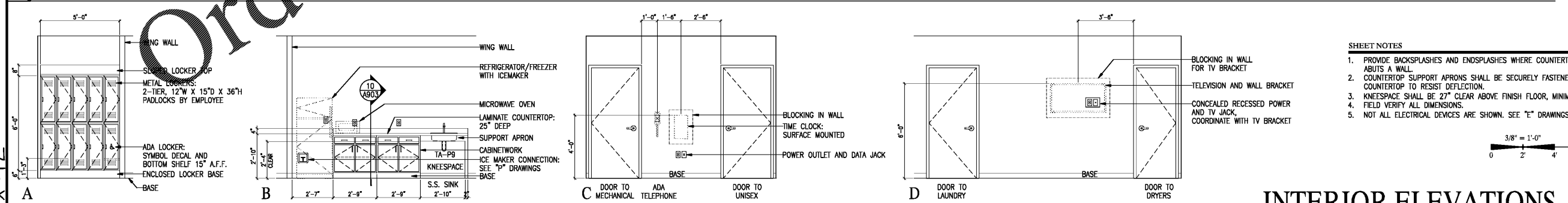

05 | 1011- BREAK

WWW.LDLINE.COM

Order Plans @

- SHEET NOTES**
1. PROVIDE BACKSPASHES AND ENDSPLASHES WHERE COUNTERTOP ABUTS A WALL.
 2. COUNTERTOP SUPPORT APRONS SHALL BE SECURELY FASTENED TO COUNTERTOP TO RESIST DEFLECTION.
 3. KNEESPACE SHALL BE 27" CLEAR ABOVE FINISH FLOOR, MINIMUM.
 4. FIELD VERIFY ALL DIMENSIONS.
 5. NOT ALL ELECTRICAL DEVICES ARE SHOWN. SEE "E" DRAWINGS.

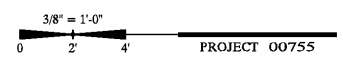

HAMPTON INN
NEW HOTEL
ASHLAND CITY, TENNESSEE
WWW.DAVIDRCARTER.NET
DAVID R. CARTER AND ASSOCIATES



INTERIOR ELEVATIONS A705

30 x 42