

FIXTURE / EGRESS PLAN
SCALE: 1/8" = 1'-0"

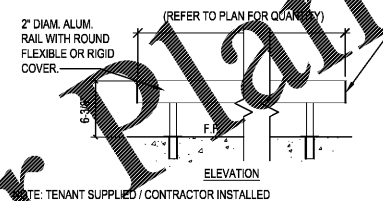

- NOTES:**
- NO GONDOLA UNITS, FIXTURES, OR PALLETS SHALL BE OVER 8'-0" AW.
 - FIXTURE PLAN IS FOR REFERENCE ONLY. CONTRACTOR SHALL CONTACT DOLLAR TREE FOR FINAL APPROVED LAYOUT.
 - MAXIMUM TRAVEL DISTANCE SHALL BE 200'-0". ACTUAL TRAVEL DISTANCE AS SHOWN: ()
 - CHECKOUTS ARE NOT ATTACHED TO FLOOR.



SHOPPING CART BUMPER DETAIL
SCALE: 1 1/2" = 1'-0"

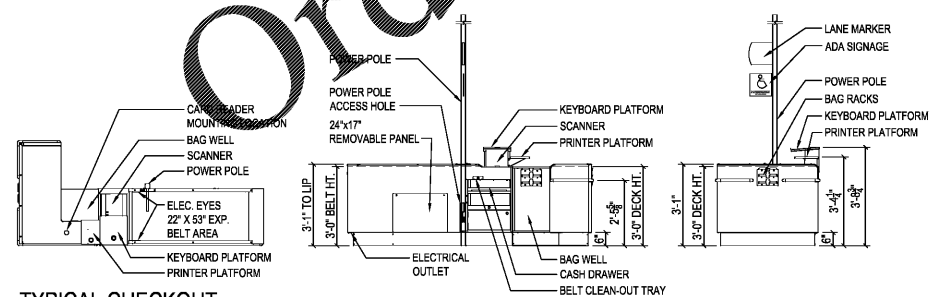

TYPICAL CHECKOUT
SCALE: NTS

- NOTE:**
- CHECKOUTS AND POWER POLES ARE TENANT SUPPLIED / CONTRACTOR INSTALLED.
 - CHECKOUT AISLES SHALL COMPLY WITH 2012 INTERNATIONAL BUILDING CODE SECTION 1109.12.2 (PROVIDE 2 when 3 or more)
 - PROVIDE SIGN DISPLAYING THE INTERNATIONAL SYMBOL OF ACCESSIBILITY IN BLUE AND WHITE ABOVE EACH CHECKOUT AISLE IN THE SAME LOCATION AS THE CHECKOUT NUMBER OR TYPE OF CHECKOUT IDENTIFICATION.

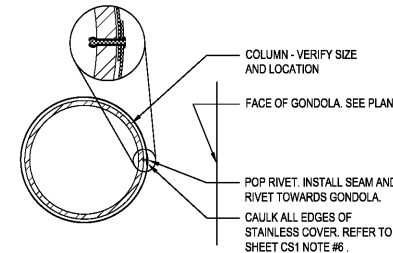

3 COLUMN DETAIL
SCALE: 1 1/2" = 1'-0"

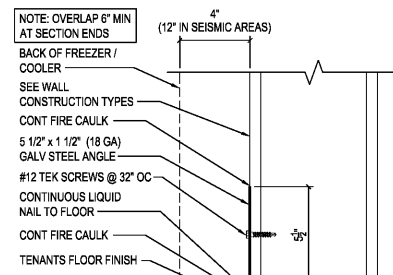

4 DETAIL
SCALE: 3" = 1'-0"

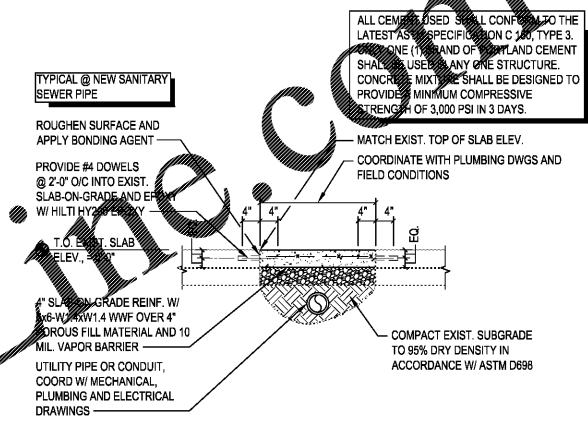

1 SLAB IN-FILL DETAIL
SCALE: 3/4" = 1'-0"

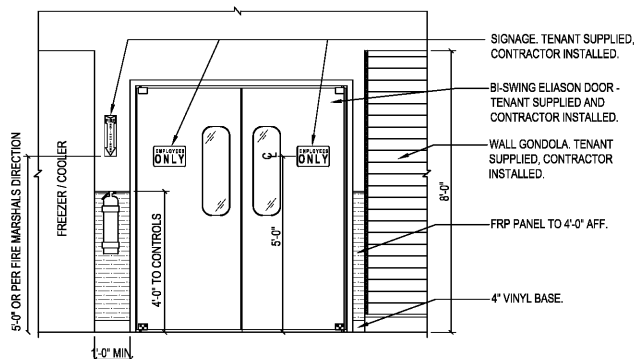

A SALES / STOCKROOM DOOR ELEVATION
SCALE: 1/2" = 1'-0"

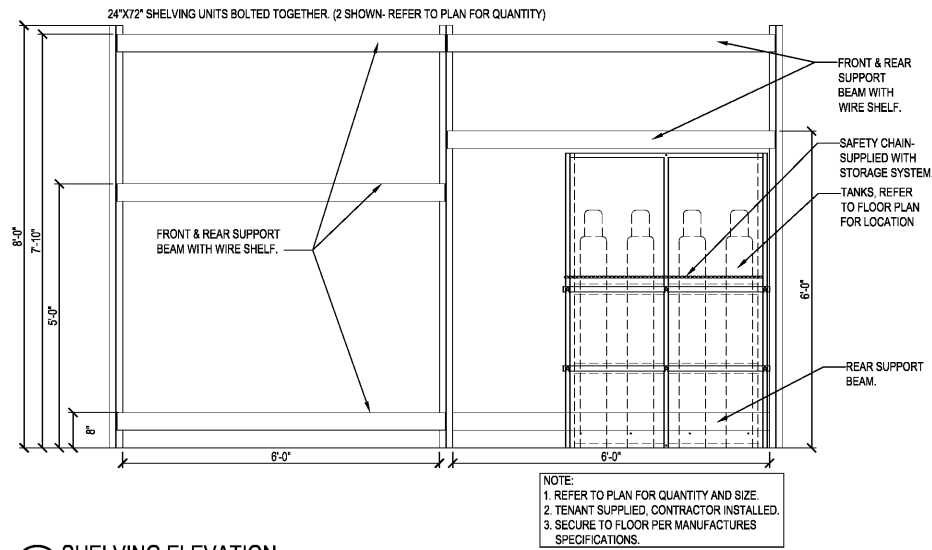

B SHELVING ELEVATION
SCALE: 3/4" = 1'-0"

description	
by	
date	revisions
5/10/2011	CSC
11/16/11	CSC
date	checked
project	drawn
designed	check
5/10/2011	RSB / DMH
11/16/11	RSB / DMH
RRMM ARCHITECTS, P.C. Robert S Berz, Jr, Architect Duane M Harver, Architect 1317 Executive Blvd, Suite 200 Chesapeake, VA 23320 (757) 622-2828 / fax (757) 622-6883	
project	drawing
DOLLAR TREE ROCKDALE PLAZA - DEAL # 11733 CONYERS, GA FIXTURE / EGRESS PLAN, DETAILS AND ELEVATIONS	
sheet	
A1.2	