

SECTION AA

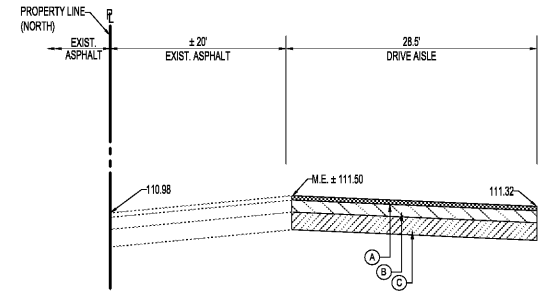

SECTION B-B

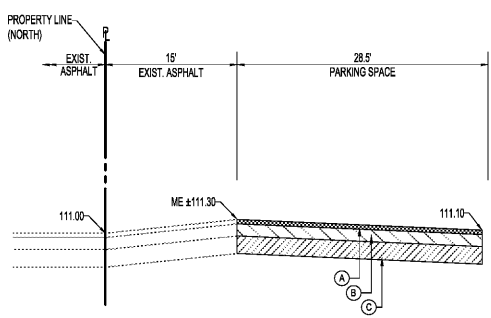
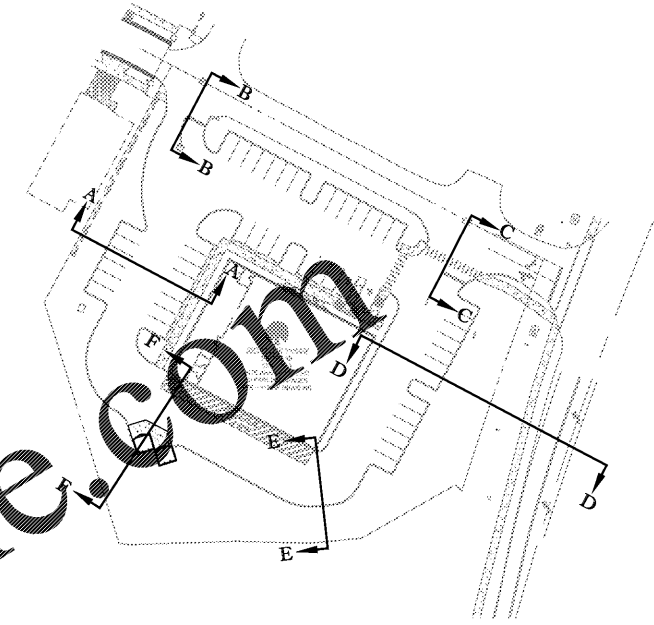
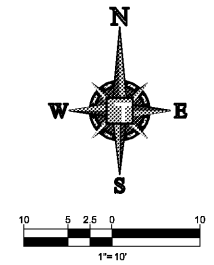

SECTION C-C

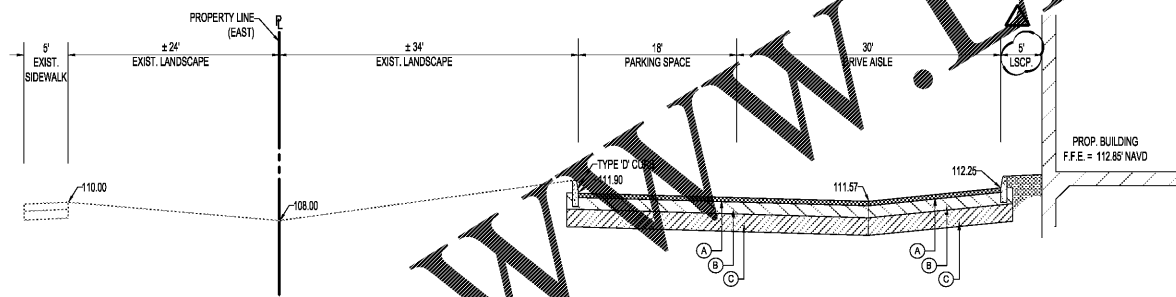

SECTION D-D

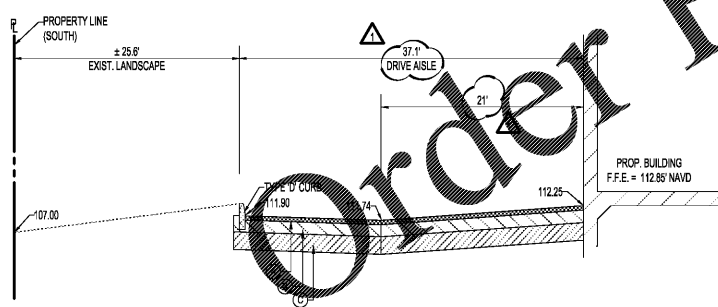

SECTION E-E

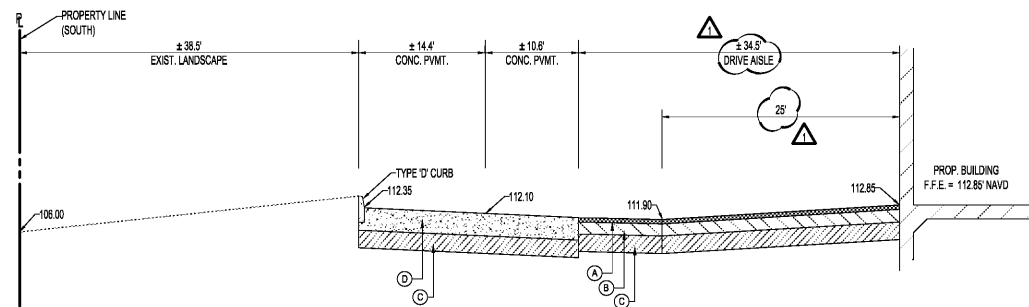

SECTION F-F

PAVEMENT LEGEND

- (A) WEARING SURFACE: (ASPHALT AREAS ONLY)
2-INCHES OF SP-9.5 FINE MIX ASPHALTIC CONCRETE (2 LIFTS). BITUMINOUS ASPHALT COARSE MAY BE INSTALLED IN SEPARATE 0.75" FIRST LIFT TO ALLOW MOBILIZATION OF EQUIPMENT. THE SECOND LIFT OF ASPHALT SHALL NOT BE PLACED UNTIL ALL OTHER WORK ON THE SITE HAS BEEN COMPLETED. UPON COMPLETION OF SECOND LIFT OF ASPHALT, ANY SCRATCHES GOUGES, OR LOSS OF AGGREGATE WILL NOT BE ACCEPTED. CONTRACTOR TO REMEDY ALL HOLES, BLEMISHES, ETC. PRIOR TO THE UNIFORM INSTALLATION OF SECOND LIFT. AFTER SECOND LIFT OF ASPHALT IS INSTALLED, TRAFFIC ROLLING IS REQUIRED.
- (B) LIME ROCK BASE: (ASPHALT, VEHICULAR PAVERS AREAS)
LIME ROCK BASE COURSE MATERIAL FOR PAVED AREAS SHALL BE A MINIMUM 10" THICKNESS AND COMPACTED TO 98% MAXIMUM DRY DENSITY PER AASHTO T-180 (LBR 100). OTHER SUBSTITUTES SHALL BE PER FDOT SPECIFICATIONS AND PROVIDE EQUIVALENT STRUCTURAL NUMBER AS ABOVE (MIN LBR 100) WITH ENGINEER'S APPROVAL.
- (C) SUB-BASE: 12" STABILIZED SUB-BASE COMPACTED TO 98% OF MAX. DRY DENSITY PER AASHTO T-180 (MIN LBR 40).
- (D) CONCRETE PAVEMENT:
6" THICK 4000 P.S.I. CONCRETE FOR VEHICULAR USE AREAS (VUA) AND 4" THICK FOR NON VUA SIDEWALK

Order Plans @ WWW.LDILine.com

<p>THOMAS ENGINEERING GROUP</p> <p>4950 W. KENNEDY BLVD, SUITE 600 TAMPA, FLORIDA 33609 Phone: (813) 378-4100 Fax: (813) 378-4040 ThomasEngineeringGroup.com</p>	<table border="1" style="width: 100%; border-collapse: collapse;"> <tr><td>REV</td><td>DATE</td><td>DRN</td><td>CHK</td></tr> <tr><td>▲</td><td>05/15/2019</td><td>CTD</td><td>CTD</td></tr> <tr><td>▲</td><td>01/17/2019</td><td>AG</td><td>CTD</td></tr> </table>	REV	DATE	DRN	CHK	▲	05/15/2019	CTD	CTD	▲	01/17/2019	AG	CTD	<table border="1" style="width: 100%; border-collapse: collapse;"> <tr><td>PER CITY OF OCOEE COMMENTS 5/13/19</td></tr> <tr><td>PER CITY OF OCOEE COMMENTS 3/29/19</td></tr> <tr><td>DESCRIPTION</td></tr> <tr><td>DOCUMENT CONTROL</td></tr> </table>	PER CITY OF OCOEE COMMENTS 5/13/19	PER CITY OF OCOEE COMMENTS 3/29/19	DESCRIPTION	DOCUMENT CONTROL	<p>DARREN J. PYPER, P.E. FLORIDA LICENSE NO. 77690 FLORIDA BUSINESS CERT. OF AUTH. NO. 27282</p>	<p>DOLLAR TREE</p> <p>OCOEE, FL CROSS SECTIONS</p> <p>PROJ. NO. FT180066 DWG. NO. C-9.0</p>
REV	DATE	DRN	CHK																	
▲	05/15/2019	CTD	CTD																	
▲	01/17/2019	AG	CTD																	
PER CITY OF OCOEE COMMENTS 5/13/19																				
PER CITY OF OCOEE COMMENTS 3/29/19																				
DESCRIPTION																				
DOCUMENT CONTROL																				