

UL E60485  
 UL E60486  
 UL E60487  
 UL E60488  
 UL E60489  
 UL E60490  
 UL E60491  
 UL E60492  
 UL E60493  
 UL E60494  
 UL E60495  
 UL E60496  
 UL E60497  
 UL E60498  
 UL E60499  
 UL E60500



ISSUE/REVISION RECORD

DATE	DESCRIPTION
07/28/19	COORDINATION SET
08/23/19	HEALTH SUBMITTAL
09/23/19	HEALTH RESPONSE
05/03/19	PERMIT/301 SET

ITEM #50 PREP /OVEN

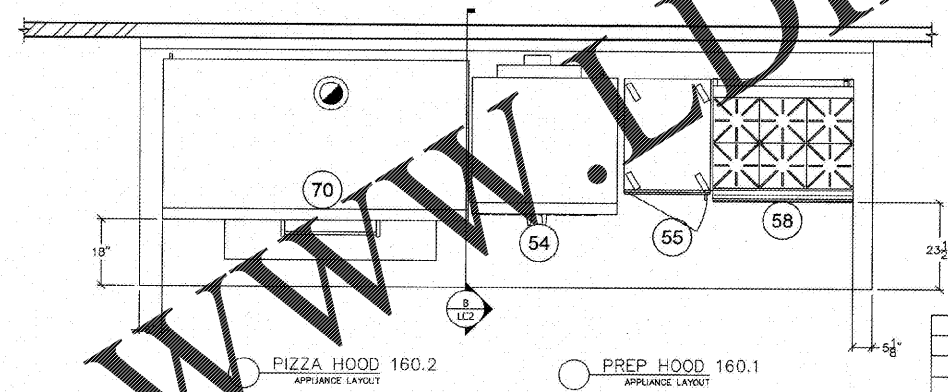
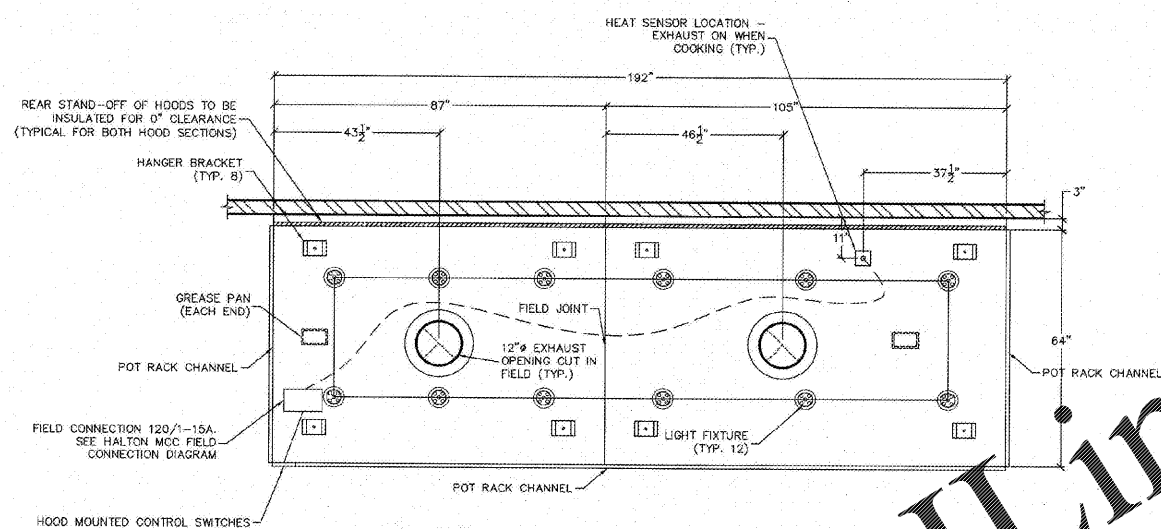

ITEM	DESCRIPTION
54	DOUBLE STACK CONVECTION OVEN
55	SMOKER OVEN
58	36" GAS RANGE
70	DOUBLE STACK PIZZA OVEN

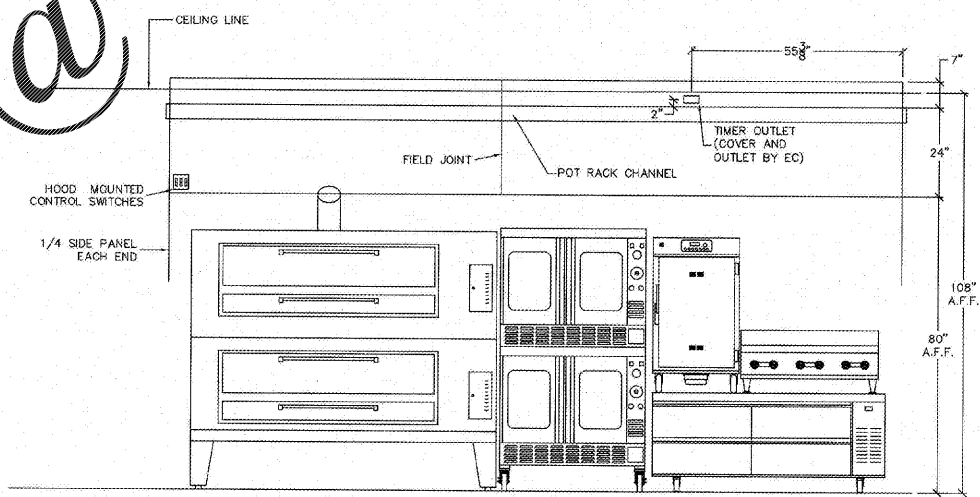
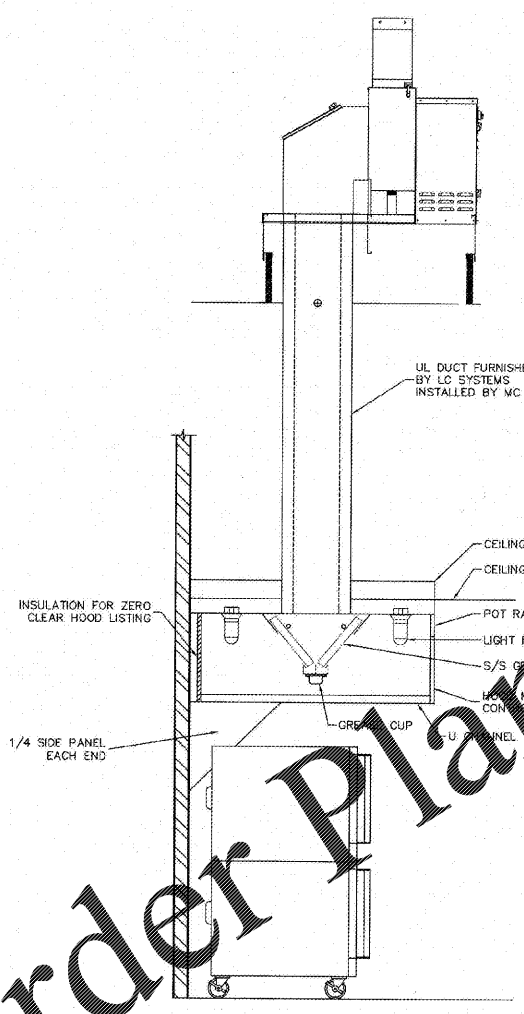

Order Plans @

WWW.DIline.com

- Review is for conformance with information given and referenced code and the design concept expressed in the contract documents.
- Conformance with contract documents remains the contractor's and supplier's responsibility.
- Plans are complete.
- Plans are in compliance with enforced codes of A.H.L.

Vaughn R. Hill, P.E.  
 Date Signed: 05/01/19  
 N. Carolina Reg. No. 015296  
 Exp. Date: 12/31/19

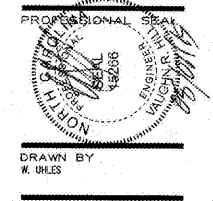

DRAWN BY  
 W. WILDS



GASTONIA  
 NORTH CAROLINA  
 EAST FRANKLIN BOULEVARD  
 & ARMSTRONG PARK ROAD

PROJECT NUMBER  
 20181046.0  
 SHEET TITLE  
 PREP HOOD  
 U19-070-02  
 SHEET NUMBER

C2