

COPYRIGHT NOTICE:
This drawing is the property of the above
mentioned professional and is not to be used
for any purpose other than the specific
project and site named herein, and cannot
be reproduced in any manner without the
express written permission from the professional.

ISSUE/REVISION RECORD	
DATE	DESCRIPTION
05/28/19	COORDINATION SET
02/20/19	HEALTH SUBMITTAL
04/24/19	HEALTH RESPONSE
05/03/19	PERMIT/BD SET

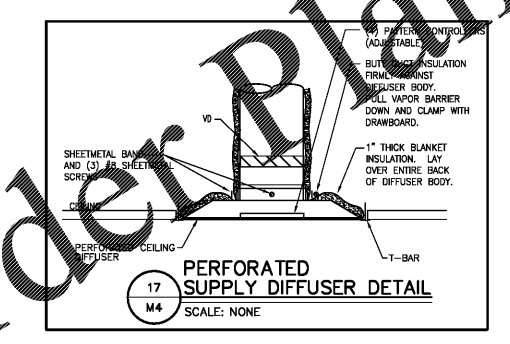
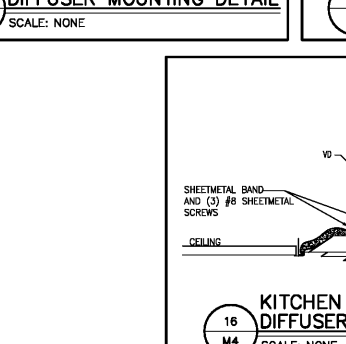
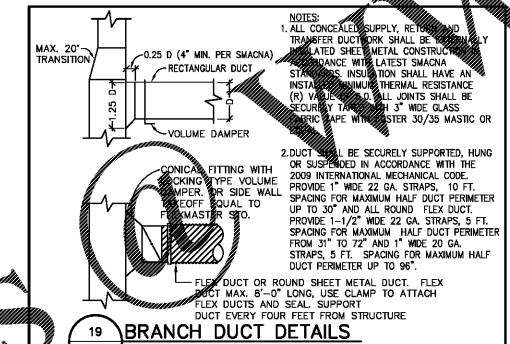
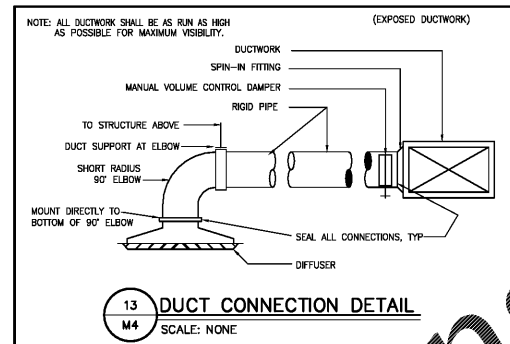
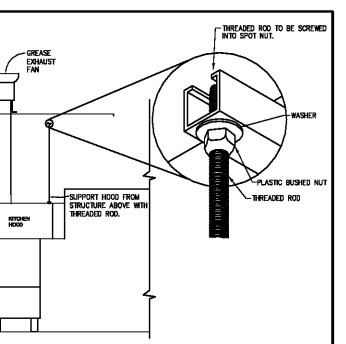
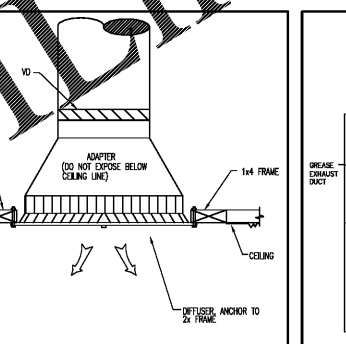
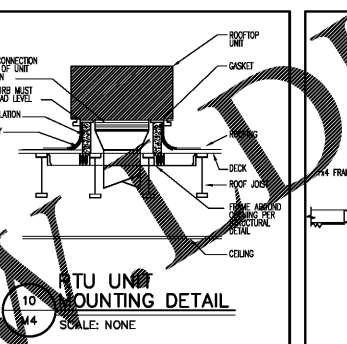
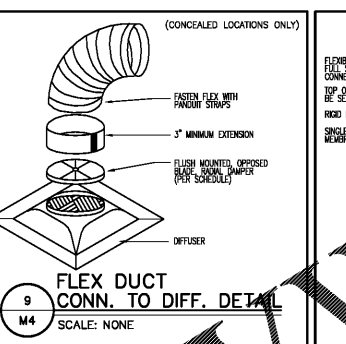
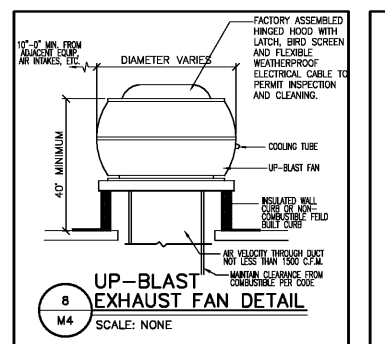
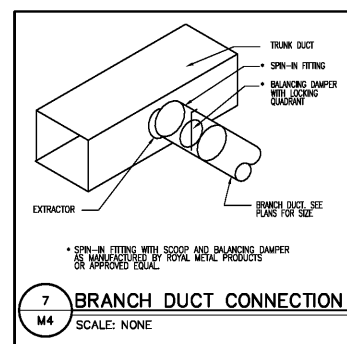
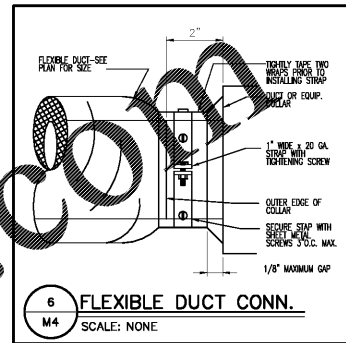
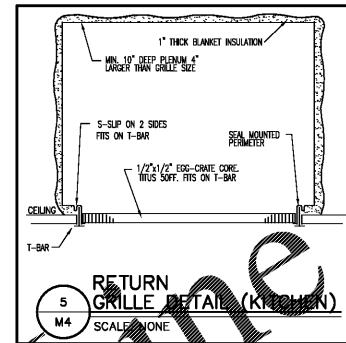
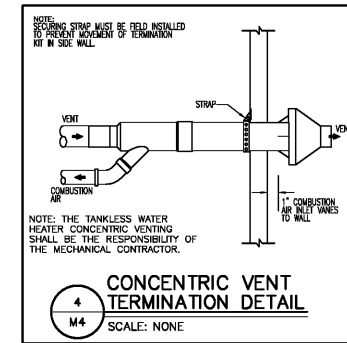
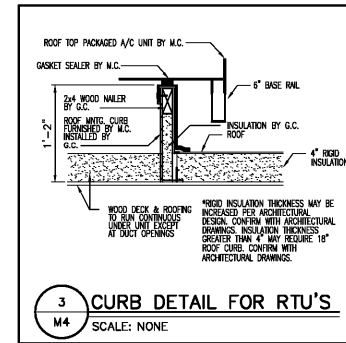
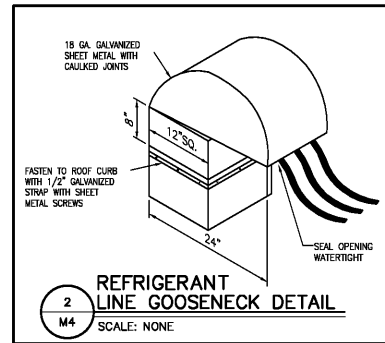
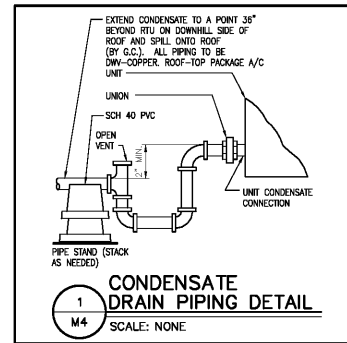

PROFESSIONAL SEAL

PROFESSIONAL IN CHARGE
R. SMITH
PROJECT MANAGER
A. HADLOW
QUALITY CONTROL
A. HADLOW
DRAWN BY
Y. YANG

PROJECT NAME
BUBBA'S 33

GASTONIA
NORTH CAROLINA
3287 E. FRANKLIN BLDVD.



PROJECT NUMBER
20181046.0

SHEET TITLE
**MECHANICAL
DETAILS**

SHEET NUMBER
M4

Order Plans