

ISSUE/REVISION RECORD

DATE	DESCRIPTION
03/28/19	COORDINATION SET
02/20/19	HEALTH SUBMITAL
04/24/19	HEALTH RESPONSE
05/03/19	PERMIT/BD SET

PROFESSIONAL SEAL

PROFESSIONAL IN CHARGE
B. BORNHORN
PROJECT MANAGER
M. HWS
QUALITY CONTROL
M. HWS
DRAWN BY
C. YEA

PROJECT NAME
BUBBA'S 33

PROJECT LOCATION
GASTONIA NORTH CAROLINA

PROJECT ADDRESS
3287 E. FRANKLIN BLVD

PROJECT NUMBER
20181046.0

SHEET TITLE
ROOF FRAMING DETAILS

SHEET NUMBER
S7

ORDER PLANS @ WWW.WLDLINE.COM

FOR FINISHES & ADDITIONAL INFO SEE ARCH. DWGS.

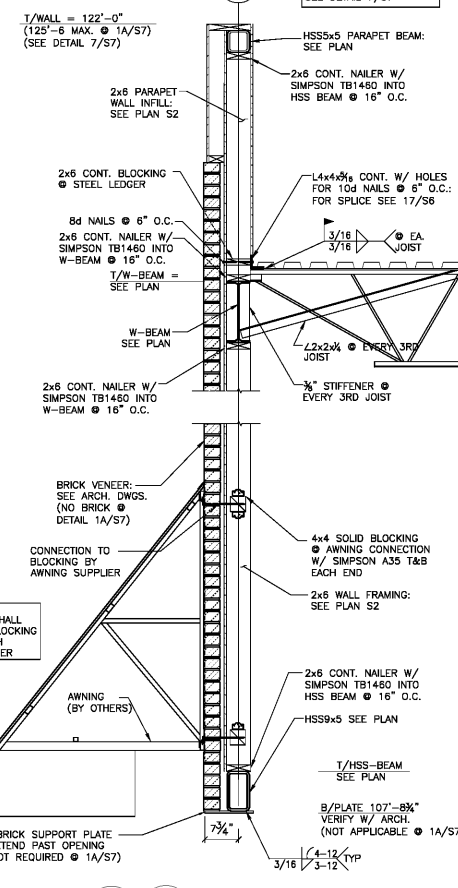

FOR FINISHES & ADDITIONAL INFO SEE ARCH. DWGS.

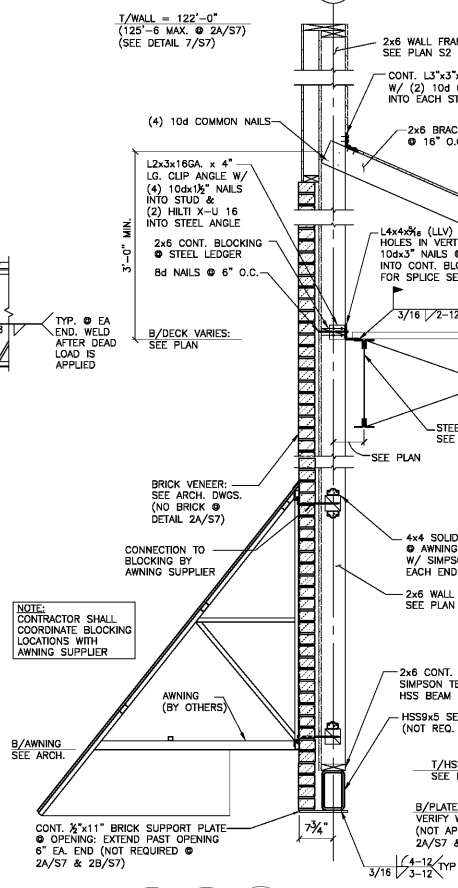

FOR FINISHES & ADDITIONAL INFO SEE ARCH. DWGS.

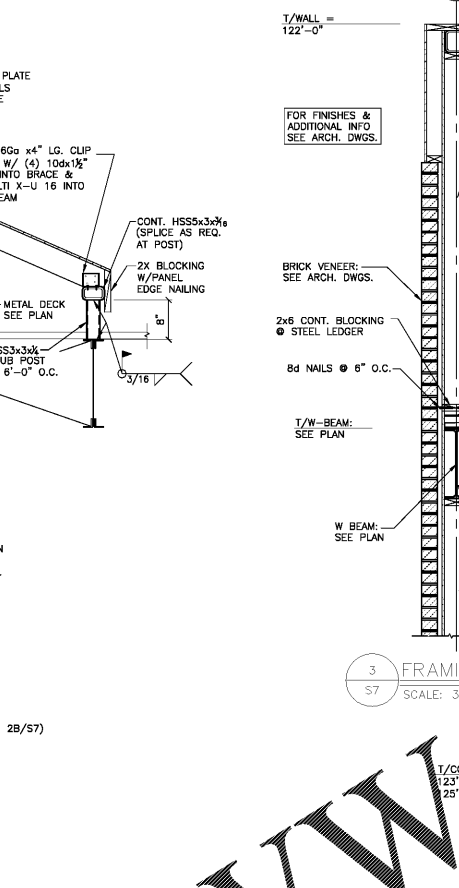

FOR FINISHES & ADDITIONAL INFO SEE ARCH. DWGS.

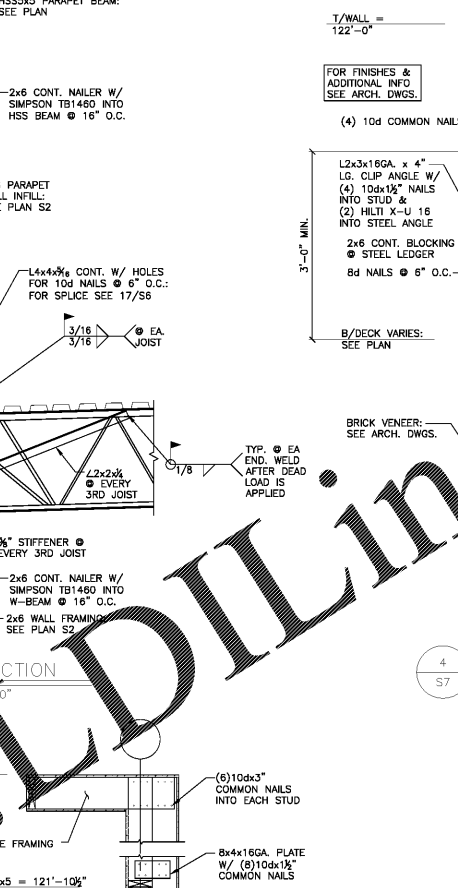

FOR FINISHES & ADDITIONAL INFO SEE ARCH. DWGS.

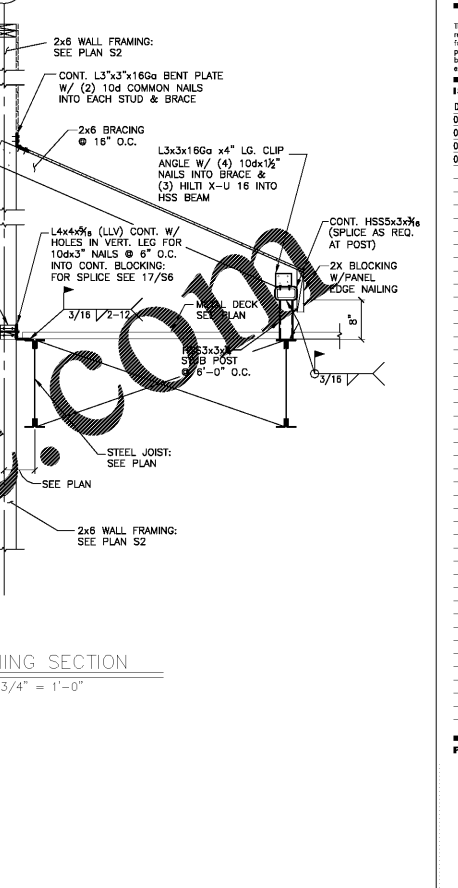

1
S7
SCALE: 3/4" = 1'-0"

2
S7
SCALE: 3/4" = 1'-0"

3
S7
SCALE: 3/4" = 1'-0"

4
S7
SCALE: 3/4" = 1'-0"

5
S7
SCALE: 3/4" = 1'-0"

1A
S7
SCALE: 3/4" = 1'-0"

2A
S7
SCALE: 3/4" = 1'-0"

3A
S7
SCALE: 3/4" = 1'-0"

4A
S7
SCALE: 3/4" = 1'-0"

5A
S7
SCALE: 3/4" = 1'-0"

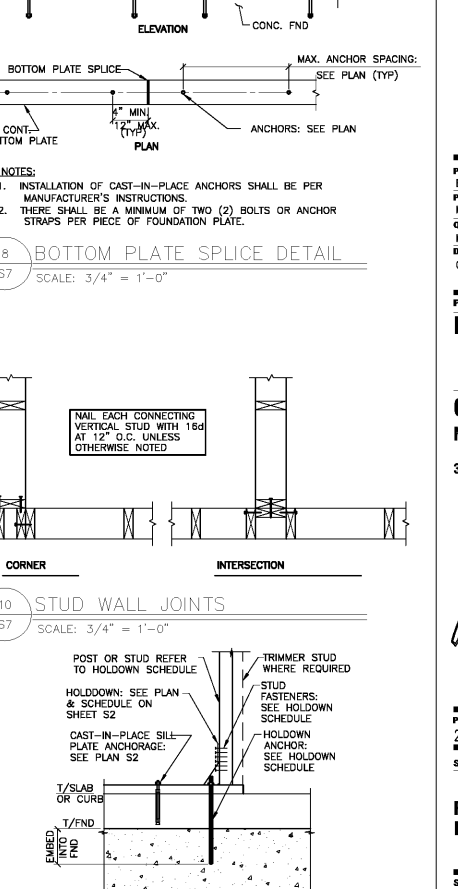
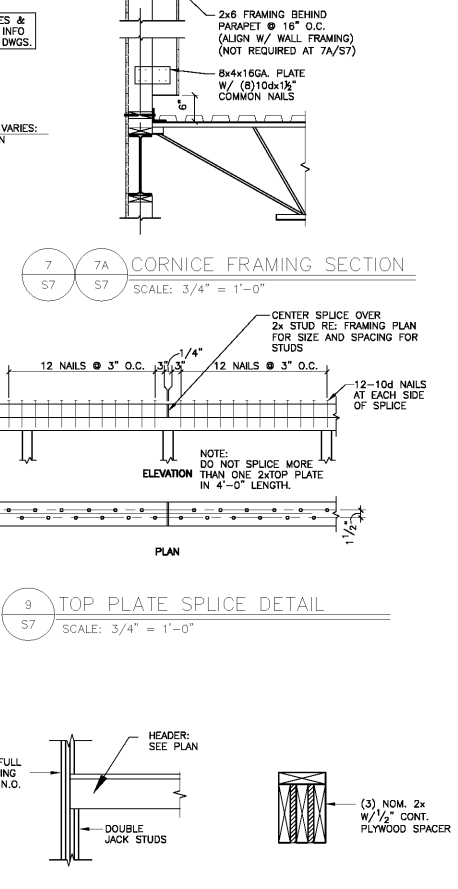
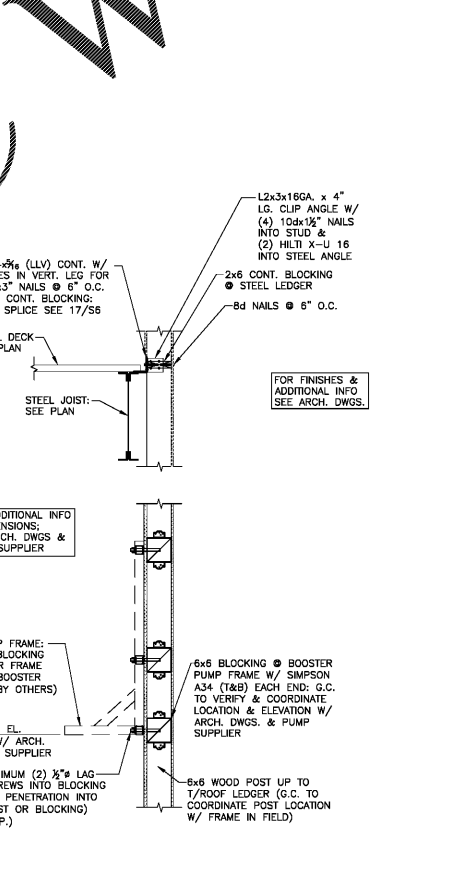
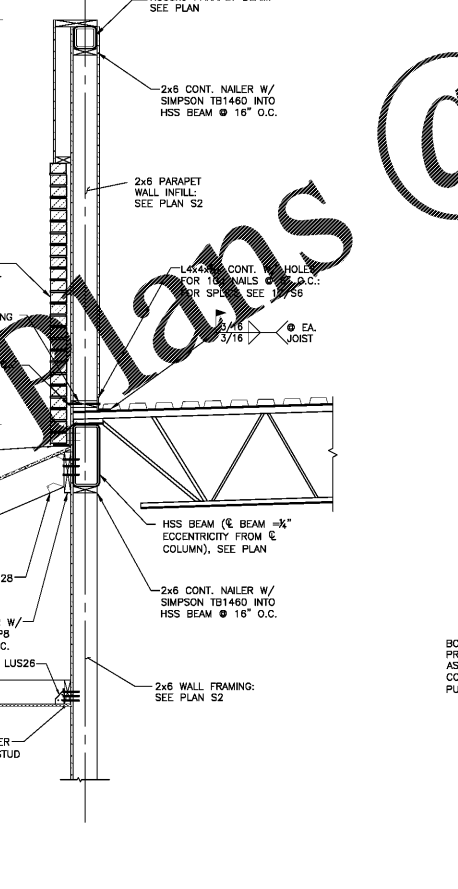
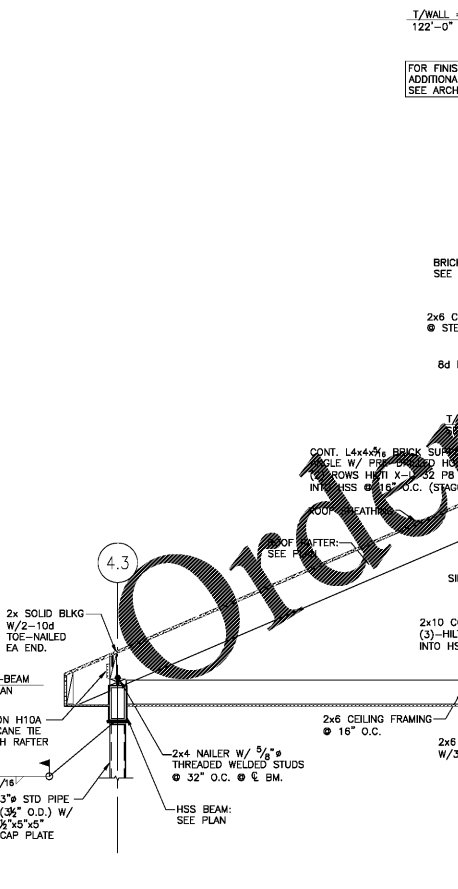

6
S7
SCALE: 3/4" = 1'-0"

7
S7
SCALE: 3/4" = 1'-0"

8
S7
SCALE: 3/4" = 1'-0"

9
S7
SCALE: 3/4" = 1'-0"

10
S7
SCALE: 3/4" = 1'-0"

11
S7
SCALE: 3/4" = 1'-0"

12
S7
SCALE: 3/4" = 1'-0"

13
S7
SCALE: 3/4" = 1'-0"

14
S7
SCALE: 3/4" = 1'-0"

15
S7
SCALE: 3/4" = 1'-0"