

CAUTION
 Vehicular traffic on other side of door. Open door slowly.

NOTE:
 1. SIGN FURNISHED BY WAWA, INSTALLED BY GC.
 2. POST AT ALL GATES AND DOORS FACING TRAFFIC LANES.

6 SIGN AT DOORS AND GATES
 A10 3/4" x 1'-0"

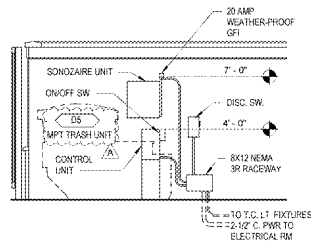

12 PARTIAL INT. ELEV.
 A10 1/4" x 1'-0"

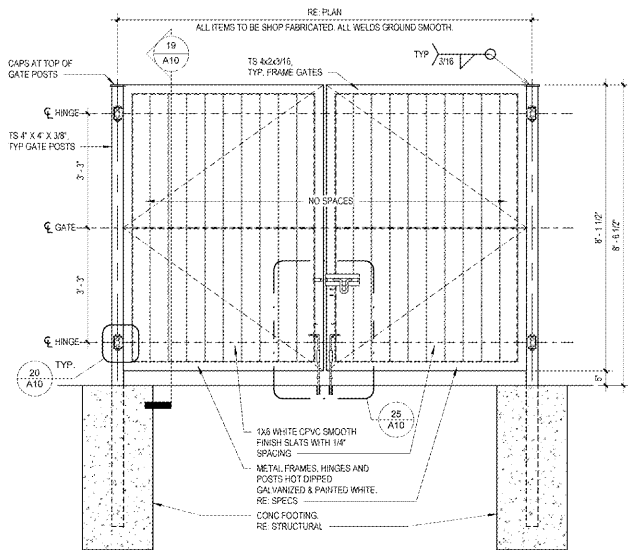

11 GATE ELEVATION
 A10 1/2" x 1'-0"

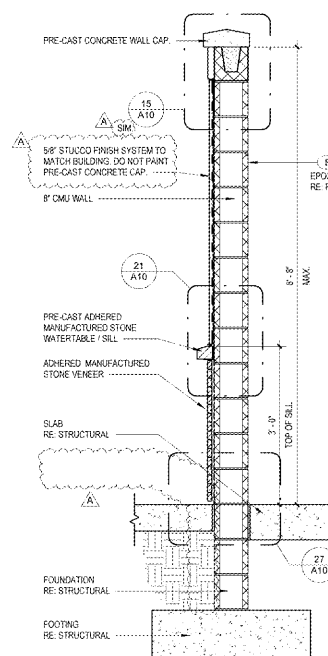

9 WALL SECTION
 A10 3/4" x 1'-0"

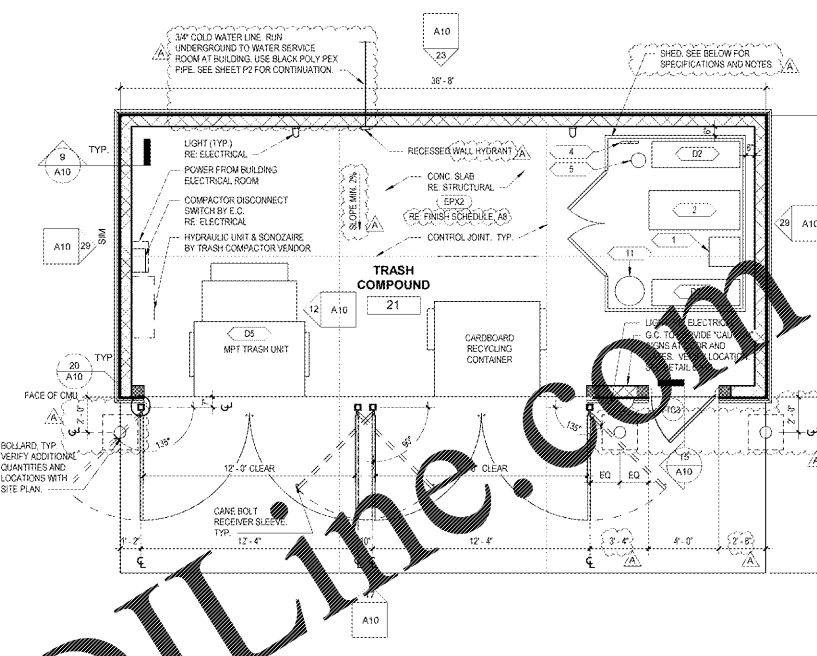

8 TRASH COMPOUND FLOOR PLAN
 A10 1/4" x 1'-0"

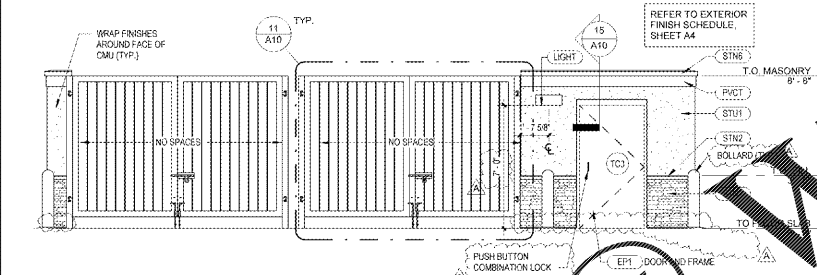

17 FRONT ELEVATION
 A10 1/4" x 1'-0"

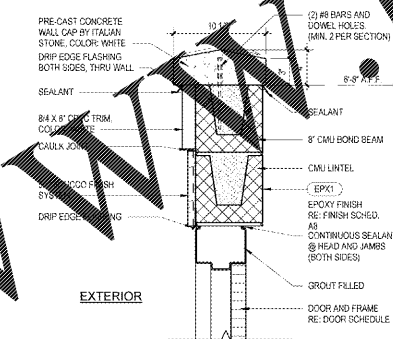

15 HEAD DETAIL
 A10 1 1/2" x 1'-0"

DOOR SCHEDULE									
#	W	HT	TH	TYPE	MATL	FRAME	THR	HDW	REMARKS
T03	3'-8"	7'-0"	1 3/4"	B	HM	HM	B	17.3	1" HEAD, SEE SHEET A1 FOR DOOR NOTES, REFER TO HARDWARE SCHEDULE IN SPECIFICATIONS MANUAL.

EQUIPMENT SCHEDULE		
EQ#	DESCRIPTION	INSTALLED BY
D	BACK OF HOUSE	
D2	STORAGE SHELVING	WAWA
D5	MPT TRASH UNIT	WAWA
Z	EXTERIOR EQUIPMENT	
1	PORTABLE POWER WASH (FUTURE)	
2	BILLY GOAT	
4	SHOVEL	
9	TRUCK CAN	
11	SPILL BUCKET	

SHED SPECIFICATIONS
 MAKE: SUPERIOR SHEDS, INC.
 MODEL: 19x7 (WIDTH) X 9-0 (DEPTH) VENTED SHED
 PLAN TRACKING #0174 (IFB 6TH EDITION - 2017)
 AGENCY PLAN #SS-B-180CR1 (IFB 6TH EDITION - 2017)
 COLOR: WHITE
 NOTES: FURNISHED AND INSTALLED BY GC UNDER SEPARATE PERMIT

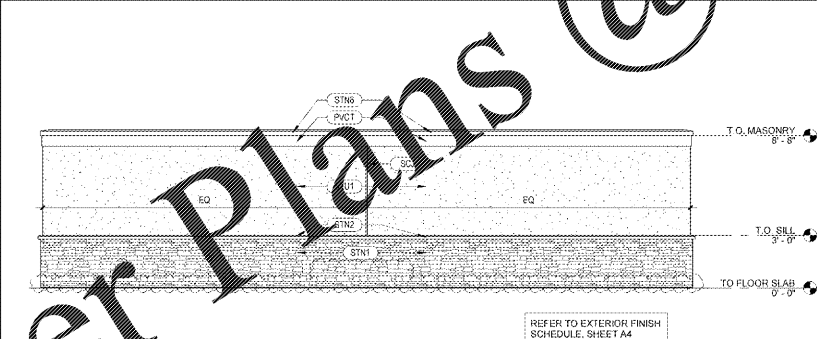

23 SIDE ELEVATION
 A10 1/4" x 1'-0"

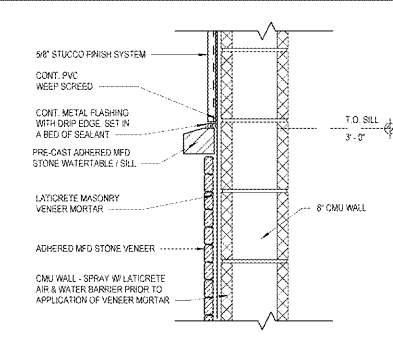

21 WALL DETAIL
 A10 1 1/2" x 1'-0"

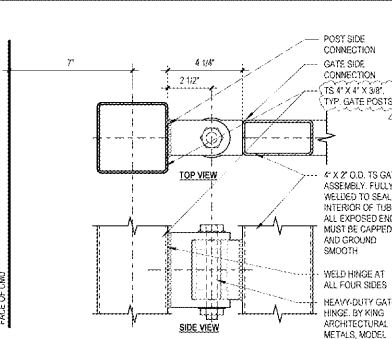

20 HINGE DETAIL
 A10 3\"/>

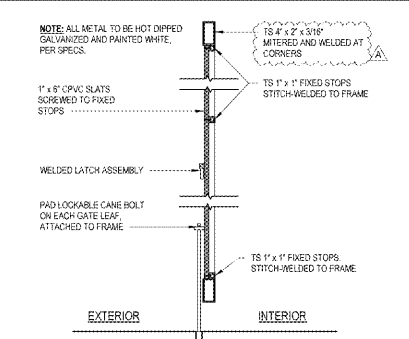

19 GATE DETAIL
 A10 1\"/>

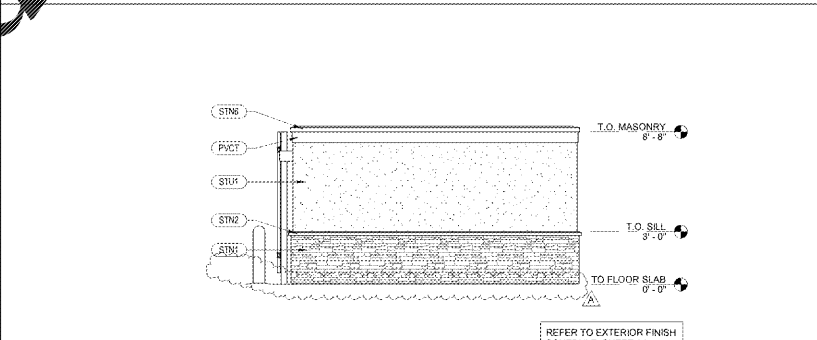

29 SIDE ELEVATION, TYP.
 A10 1/4" x 1'-0"

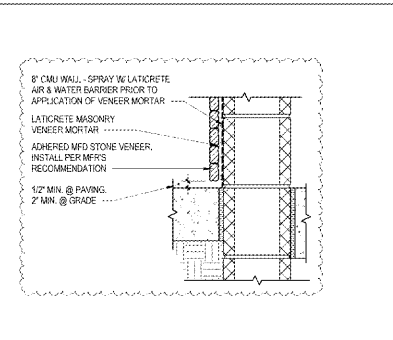

27 BASE DETAIL
 A10 1 1/2" x 1'-0"

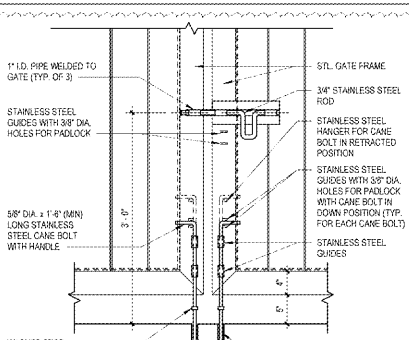

25 CANE BOLT & LATCH DETAIL
 A10 1 1/2" x 1'-0"

Order Plans @

Revision Schedule	
No.	Description
1	ISSUE FOR PERMIT
2	PRELIMINARY REVIEW
3	SET
4	REVISED SET
5	REVISED SET