

1 BUILDING SECTION  
1/8" = 1'-0"

NOTE: ALL EXTERIOR WALLS TO HAVE R-30 INSULATION

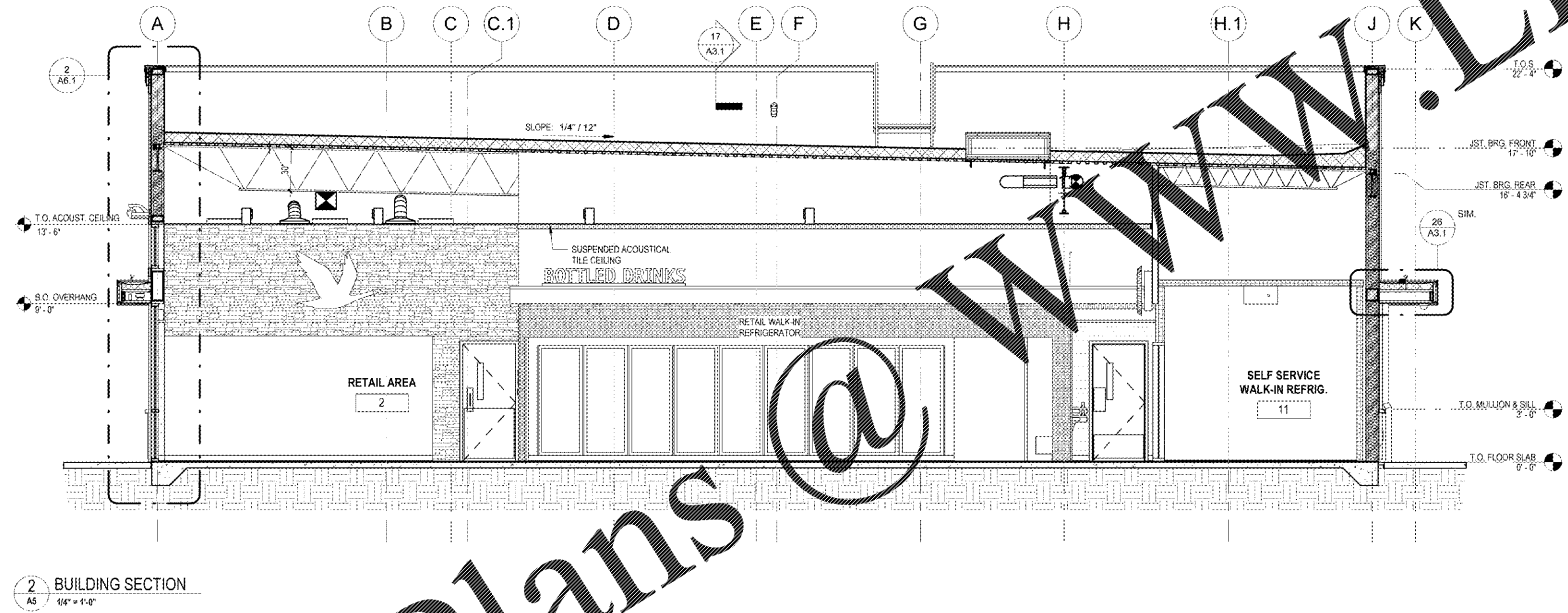

2 BUILDING SECTION  
1/8" = 1'-0"

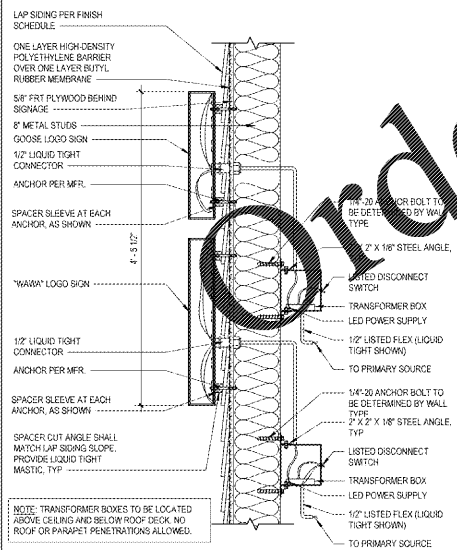

3 SIGNAGE DETAIL @ LAP SIDING (IF REQ'D)  
1" = 1'-0"

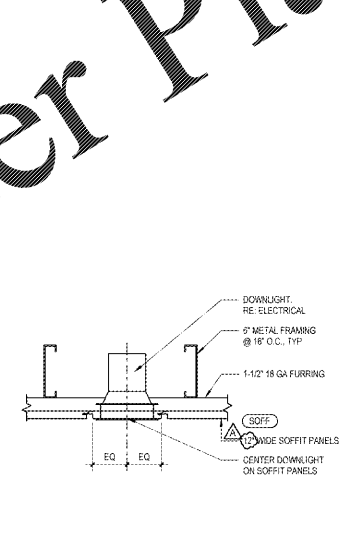

4 PORCH/ENTRY SOFFIT  
1 1/2" = 1'-0"

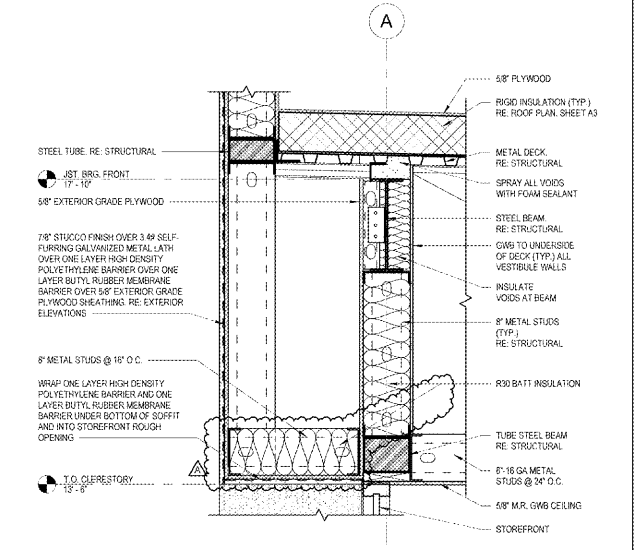

5 SOFFIT DETAIL @ FRONT ENTRY  
1" = 1'-0"

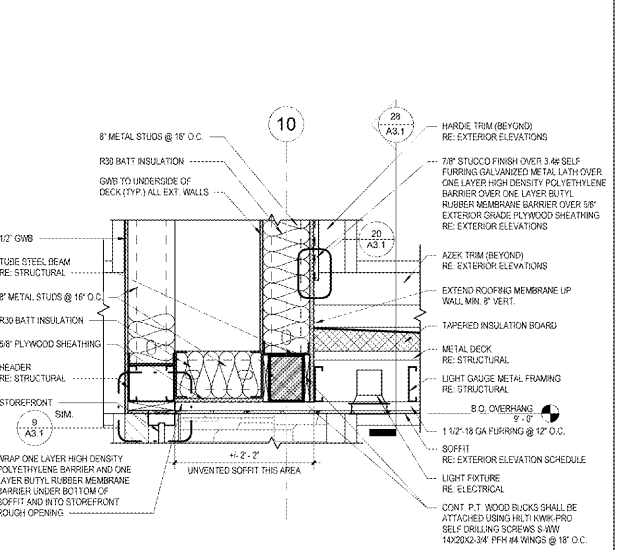

6 SOFFIT DETAIL @ SIDE ENTRY  
1" = 1'-0"

1925 Prospect Ave.  
Orlando, FL 32814  
P (407) 661-9100  
F (407) 661-9101  
www.epi.com

**Chao & Peterson**  
Architects Engineers Planners

CLIENT NAME  
**WAWA**  
280 WEST BALTIMORE PIKE  
WAWA, PENNSYLVANIA 19063

PROJECT NAME  
**WAWA F85FB 2019.01 STORE #5357-DOR**  
NW 87TH AVE. & NW 33RD ST.  
DORAL, FLORIDA

BUILDING SECTIONS

SHEET TITLE

No.	Description	Date
1	PRELIMINARY SET	08/17/2019
2	REVISED SET	08/20/2019
3	REVISED SET	08/20/2019
4	REVISED SET	08/20/2019
5	REVISED SET	08/20/2019
6	REVISED SET	08/20/2019

PROJECT NO. 271108  
DATE 08/20/19  
DRAWN WAWA  
CHECKED DU

1925 PROSPECT AVE.  
ORLANDO, FL 32814  
P (407) 661-9100  
F (407) 661-9101  
WWW.EPI.COM

A5