

- NOTES
1. CONTRACTOR TO INSTALL AND MAINTAIN ORANGE BARRIER PER PLAN, PER AROUND EXISTING TREES WHERE DELINEATED ON PLAN.
  2. NO PART OF EQUIPMENT OR MATERIALS SHALL BE PERMITTED INSIDE THIS AREA.
  3. MAINTAIN BARRIER DURING THROUGH CONSTRUCTION. REMOVE BARRIER UPON COMPLETION OF PROJECT.
  4. REFER TO MCDNR STANDARDS FOR GENERAL SPECIFICATIONS FOR TREE PROTECTION.  
6" MIN. WIDTH FOR 2" CAL. TREES OR SMALLER.  
ONE FOOT OF LINEAR DISTANCE FROM THE TREE TRUNK FOR EACH INCH OF TRUNK DIAMETER, OR 1/2 HEIGHT OF THE TREE WHICHEVER IS GREATER UNLESS OTHERWISE SHOWN ON PLAN.

4 Temporary Tree Protection Barricade  
N.T.S.

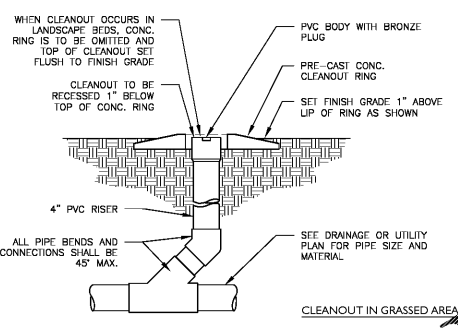
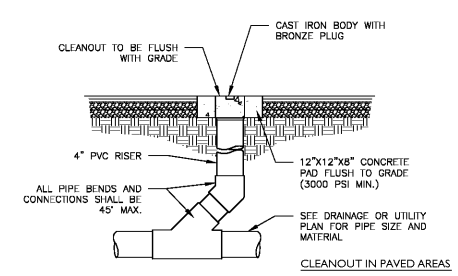

NOTE: ENGRAVE "SS" IN SANITARY SEWER PLUG AND ENGRAVE "SD" IN STORM DRAIN PLUG.

3 Cleanout  
N.T.S.

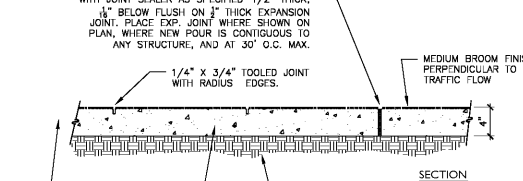
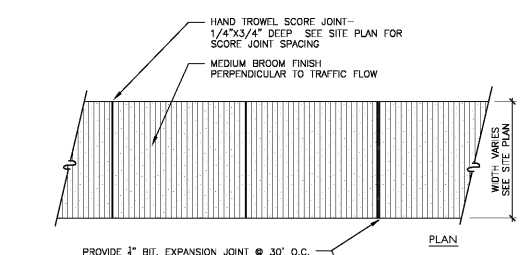

2 Concrete Sidewalk Detail  
N.T.S.

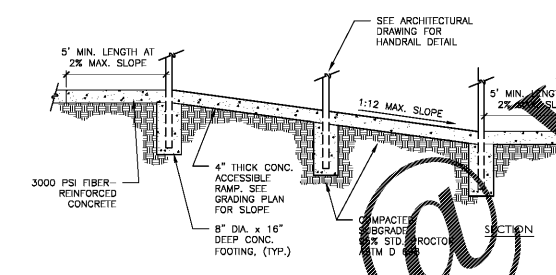

6 Accessible Ramp with Handrail Detail  
N.T.S.

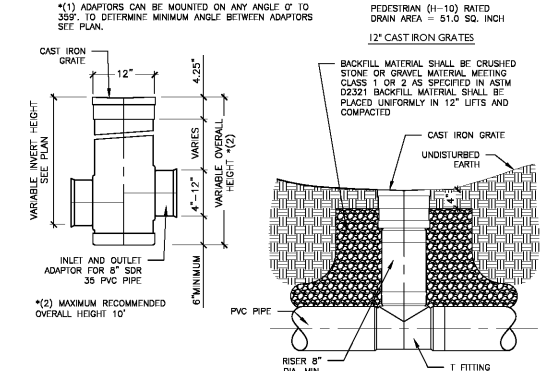
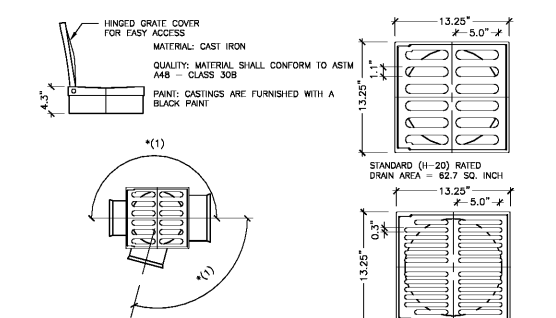

1 Area Inlet Detail  
N.T.S.

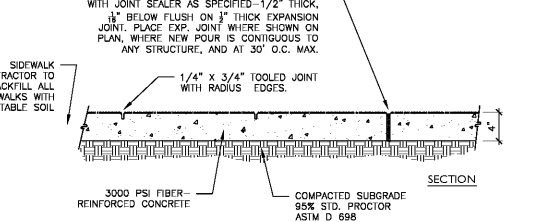
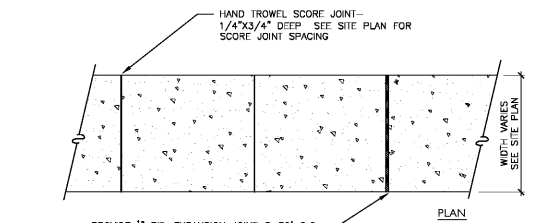

5 Exposed Aggregate Concrete Sidewalk Detail  
N.T.S.

Order Plans



SCO #16-15889-02A

RICHMOND  
COMMUNITY  
COLLEGE

LEE BUILDING  
STUDENT SERVICES &  
CAREER CENTER  
VOL.2

BID DOCUMENTS

SITE  
CONSTRUCTION  
DETAILS

DATE 04.05.2019  
PROJECT NO 16063

REVISIONS

NO	DATE	DESCRIPTION

THIS DRAWING IS THE PROPERTY OF ADW ARCHITECTS, PA AND SHALL NOT BE REPRODUCED OR COPIED IN WHOLE OR IN PART. IT SHALL NOT BE USED ON ANY OTHER PROJECT OR GIVEN TO ANY OTHER COMPANY OR AGENCY WITHOUT THE CONSENT OF ADW ARCHITECTS, PA.



SEAL 4/5/19

SHEET NUMBER C501