

7 INTERIOR ELEVATION  
SCALE: 3/16" = 1'-0"

8 INTERIOR ELEVATION  
SCALE: 3/16" = 1'-0"

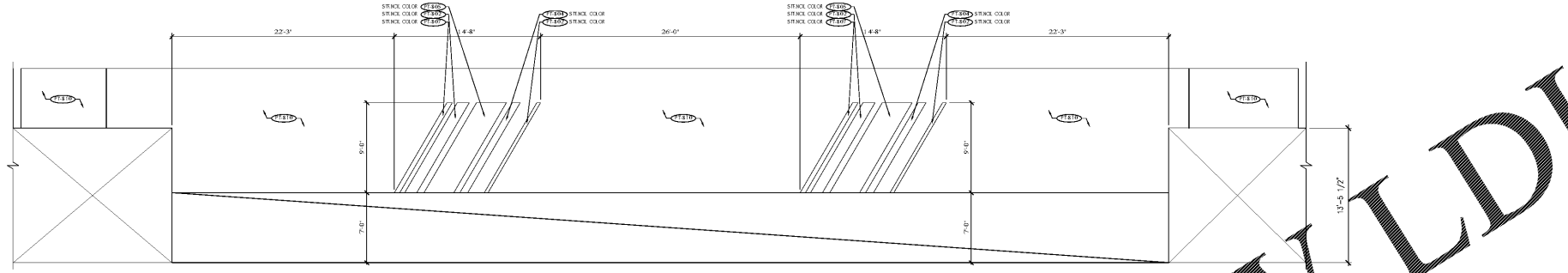

9 INTERIOR ELEVATION  
SCALE: 3/16" = 1'-0"

- DECOR FINISH NOTES:**
- VERIFY LOCAL AGENCY REQUIREMENTS REGARDING CHIMNEY WALLS & ROOF FINISHES BEFORE PROCEEDING.
  - ALL WALLS SHOULD BE FINISHED TO MINIMUM FINISH LINE OR SEET AT FINISHMENT LINE UNLESS OTHERWISE NOTED.
  - WALLS AND CEILING SHALL BE PAINTED OR FINISHED TO BE DESCRIBED IN THIS SCHEDULE. WALLS SHALL BE PAINTED WITH PARI-PRIME 2.0. FINISH WALL COLOR SHALL BE 100% MATCH TO THE FINISH SCHEDULE. WALLS SHALL BE PAINTED TO THE FINISH LINE UNLESS OTHERWISE NOTED.
  - CONTRACTOR SHALL VERIFY ALL FINISHES TO BE USED FOR THE PROJECT. CONTRACTOR SHALL VERIFY ALL FINISHES TO BE USED FOR THE PROJECT. CONTRACTOR SHALL VERIFY ALL FINISHES TO BE USED FOR THE PROJECT.
  - ALL FINISHES SHALL BE APPLIED TO THE FINISH LINE UNLESS OTHERWISE NOTED.
  - CONTRACTOR SHALL VERIFY ALL FINISHES TO BE USED FOR THE PROJECT. CONTRACTOR SHALL VERIFY ALL FINISHES TO BE USED FOR THE PROJECT.
  - CONTRACTOR SHALL VERIFY ALL FINISHES TO BE USED FOR THE PROJECT. CONTRACTOR SHALL VERIFY ALL FINISHES TO BE USED FOR THE PROJECT.
  - CONTRACTOR SHALL VERIFY ALL FINISHES TO BE USED FOR THE PROJECT. CONTRACTOR SHALL VERIFY ALL FINISHES TO BE USED FOR THE PROJECT.
  - CONTRACTOR SHALL VERIFY ALL FINISHES TO BE USED FOR THE PROJECT. CONTRACTOR SHALL VERIFY ALL FINISHES TO BE USED FOR THE PROJECT.
  - CONTRACTOR SHALL VERIFY ALL FINISHES TO BE USED FOR THE PROJECT. CONTRACTOR SHALL VERIFY ALL FINISHES TO BE USED FOR THE PROJECT.
  - CONTRACTOR SHALL VERIFY ALL FINISHES TO BE USED FOR THE PROJECT. CONTRACTOR SHALL VERIFY ALL FINISHES TO BE USED FOR THE PROJECT.
  - CONTRACTOR SHALL VERIFY ALL FINISHES TO BE USED FOR THE PROJECT. CONTRACTOR SHALL VERIFY ALL FINISHES TO BE USED FOR THE PROJECT.
  - CONTRACTOR SHALL VERIFY ALL FINISHES TO BE USED FOR THE PROJECT. CONTRACTOR SHALL VERIFY ALL FINISHES TO BE USED FOR THE PROJECT.
  - CONTRACTOR SHALL VERIFY ALL FINISHES TO BE USED FOR THE PROJECT. CONTRACTOR SHALL VERIFY ALL FINISHES TO BE USED FOR THE PROJECT.
  - CONTRACTOR SHALL VERIFY ALL FINISHES TO BE USED FOR THE PROJECT. CONTRACTOR SHALL VERIFY ALL FINISHES TO BE USED FOR THE PROJECT.

**FINISH SCHEDULE**  
FOR REFERENCE ONLY. REFER TO ARCH. CDS FOR SPECIFICATIONS.

SYMBOL	DESCRIPTION	NOTES	APPROX. QUANTITY	BY GC
1	BUMPER & CORNER GUARD			
2	CLADDING			
3	CERAMIC TILE			
4	VINYL TILE			
5	PAINT			
6	WALL COVERING			
7	CARPET TILE			

Order Plans @ [www.LDILine.com](http://www.LDILine.com)

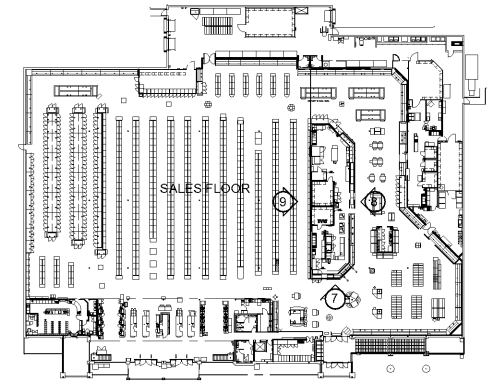

KEY PLAN  
N/S

- SHOWN ON KEY - SEE COLOR ELEVATIONS**
- 1. PAINT FINISH TO MATCH EXISTING FINISHES
  - 2. PAINT FINISH TO MATCH EXISTING FINISHES
  - 3. PAINT FINISH TO MATCH EXISTING FINISHES
  - 4. PAINT FINISH TO MATCH EXISTING FINISHES
  - 5. PAINT FINISH TO MATCH EXISTING FINISHES
  - 6. PAINT FINISH TO MATCH EXISTING FINISHES
  - 7. PAINT FINISH TO MATCH EXISTING FINISHES
  - 8. PAINT FINISH TO MATCH EXISTING FINISHES
  - 9. PAINT FINISH TO MATCH EXISTING FINISHES
  - 10. PAINT FINISH TO MATCH EXISTING FINISHES
  - 11. PAINT FINISH TO MATCH EXISTING FINISHES
  - 12. PAINT FINISH TO MATCH EXISTING FINISHES
  - 13. PAINT FINISH TO MATCH EXISTING FINISHES
  - 14. PAINT FINISH TO MATCH EXISTING FINISHES
  - 15. PAINT FINISH TO MATCH EXISTING FINISHES
  - 16. PAINT FINISH TO MATCH EXISTING FINISHES
  - 17. PAINT FINISH TO MATCH EXISTING FINISHES
  - 18. PAINT FINISH TO MATCH EXISTING FINISHES
  - 19. PAINT FINISH TO MATCH EXISTING FINISHES
  - 20. PAINT FINISH TO MATCH EXISTING FINISHES

**d fab**  
DESIGN FABRICATIONS

1100 EAST MANCONE AVE.  
SUITE 100  
MILFORD HEIGHTS, ME 04801  
T 800.968.9440  
F 248.597.0989  
designers@dfabdesign.com

COPYRIGHT © 2019  
ALL DRAWINGS AND DESIGNS ARE THE SOLE PROPERTY OF DESIGN FABRICATIONS, INC. THESE DRAWINGS ARE NOT TO BE COPIED WITHOUT WRITTEN CONSENT FROM DESIGN FABRICATIONS, INC. THESE DRAWINGS WERE PREPARED EXCLUSIVELY FOR THIS PROJECT. IT IS ILLEGAL FOR UNAUTHORIZED PERSONS TO USE THESE DRAWINGS OR DISCLOSE THEM FOR ANY OTHER PROJECT.

DO NOT SCALE DRAWINGS - USE FIGURED DIMENSIONS ONLY.

PROJECT NAME: KROGER GA-478  
PROJECT LOCATION: 3162 JOHNSON FERRY ROAD, MARIETTA, GA

ISSUED FOR: 80% REVIEW  
DATE: 03/22/19

NO. REVISED BY: DATE  
A XXX XXX

DRAWN: BP / RA  
CHECKED: CW  
SCALE: 3/16" = 1'-0"  
JOB NO.: NA  
SHEET # 12.3