

DIMENSIONS SCHEDULE FOR CONCRETE PIERS									
DIMENSIONS									
PIPE SIZE	B	W	M	N	S	P	X-BARS	Y-BARS	Z-BARS
8"	1'-0"	8"	3'-8"	2'-4"	10"	10"	5#4@9"	4#4@8"	2#4
10"	1'-0"	10"	3'-6"	2'-8"	10"	10"	5#4@9"	4#4@8"	2#4
12"	2'-0"	1'-0"	4'-0"	3'-0"	1'-0"	1'-0"	6#4@8"	5#4@8"	2#4
16"	2'-4"	1'-0"	4'-10"	3'-6"	1'-3"	1'-3"	6#4@8"	5#4@9"	2#4
18"	2'-6"	1'-0"	5'-6"	4'-0"	1'-5"	1'-5"	7#4@8"	7#4@7"	2#4
20"	2'-8"	1'-0"	6'-0"	4'-0"	1'-6"	1'-6"	7#4@8.5"	7#4@7"	2#4
24"	3'-0"	1'-0"	6'-0"	4'-0"	1'-6"	1'-6"	8#4@8"	7#4@7"	2#4

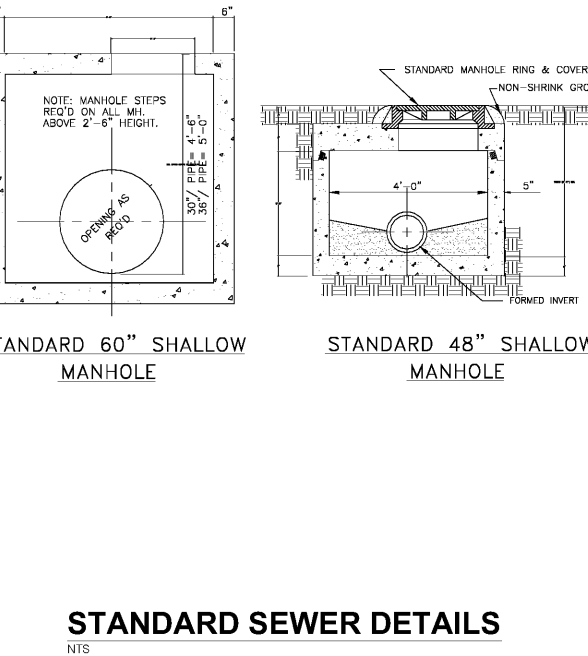
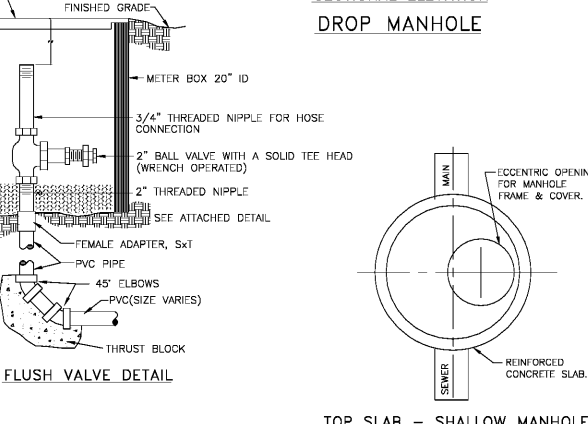
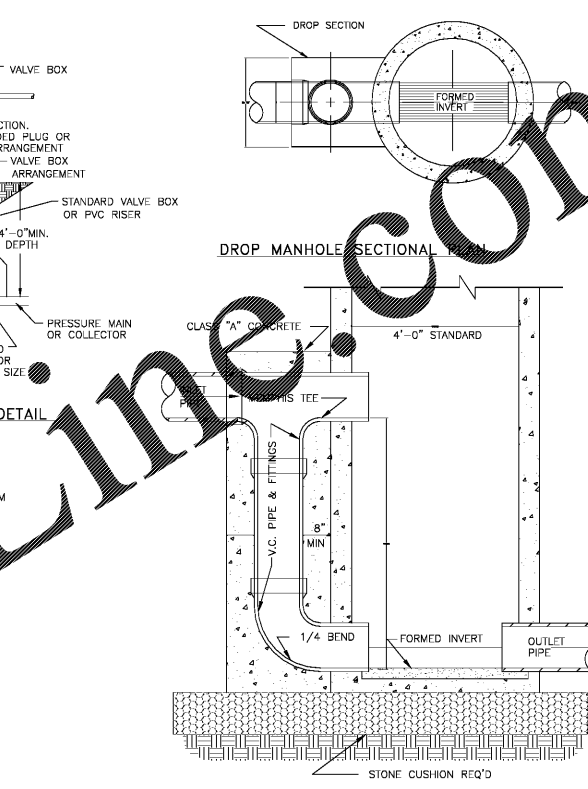
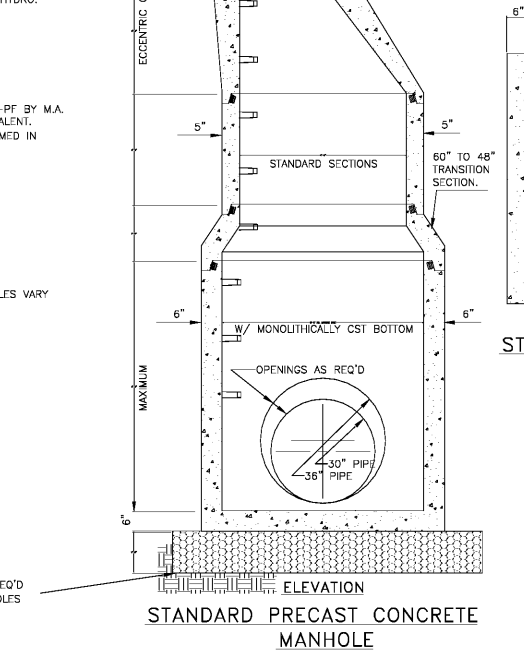
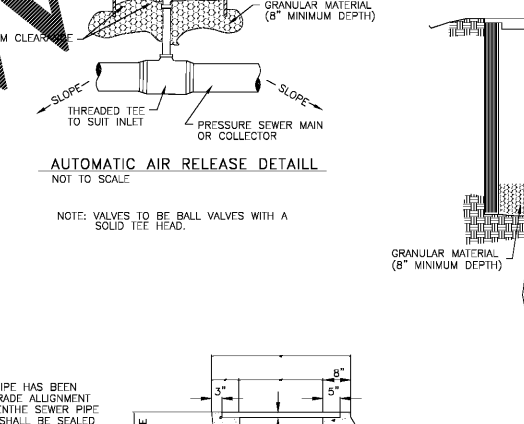
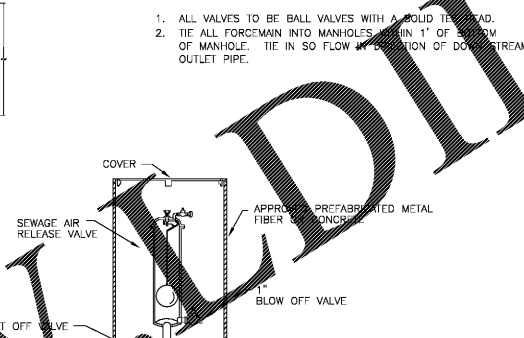
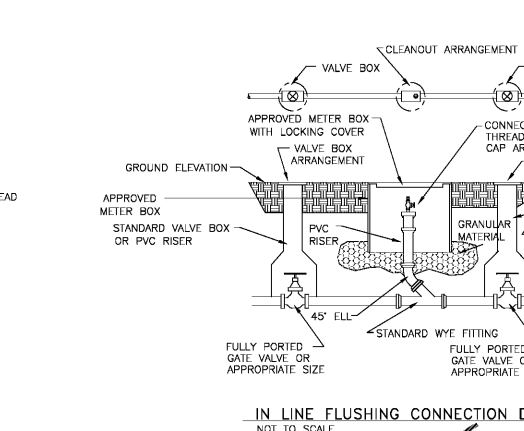
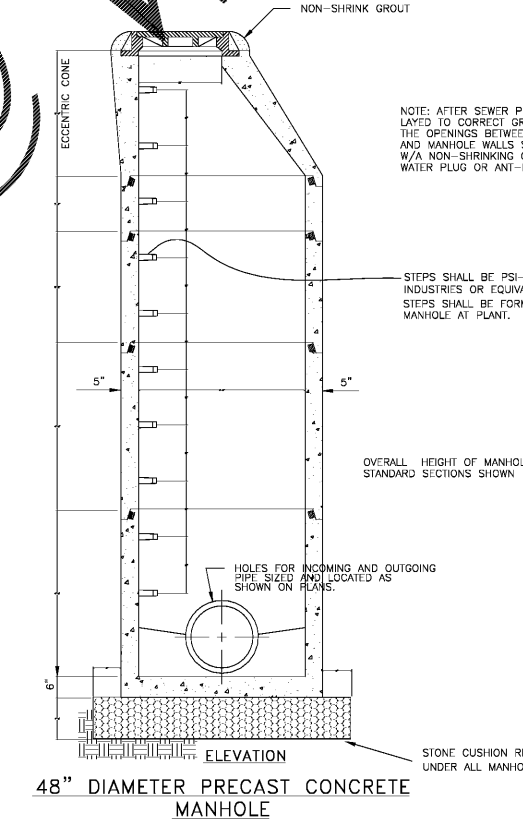
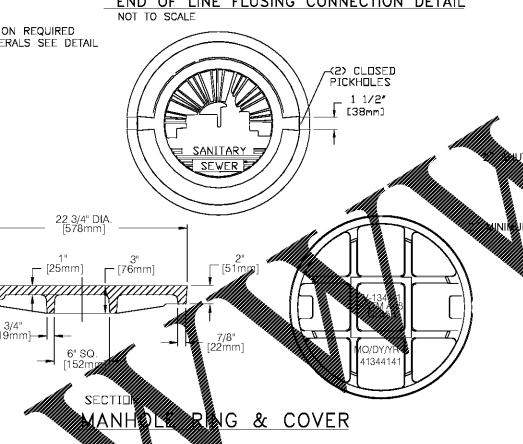
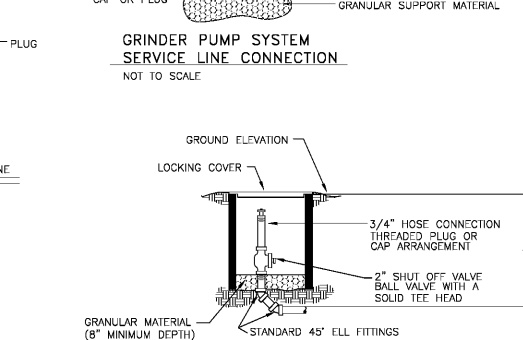
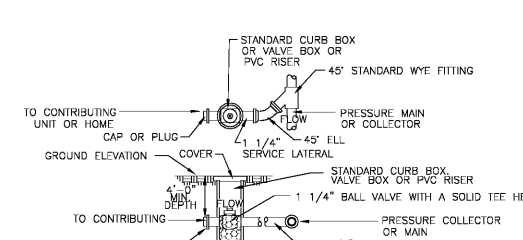
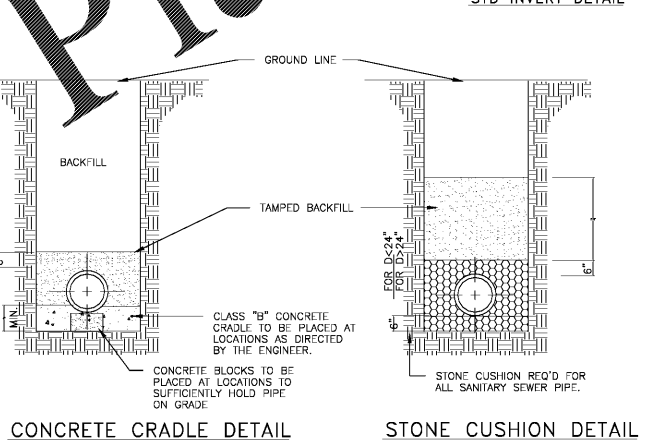
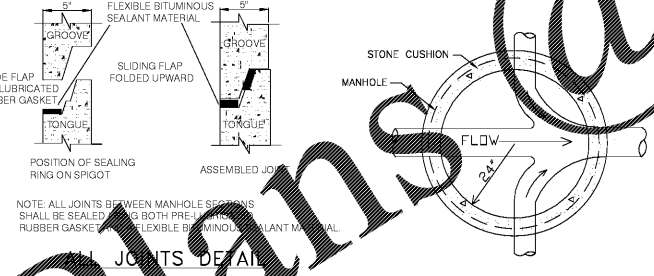
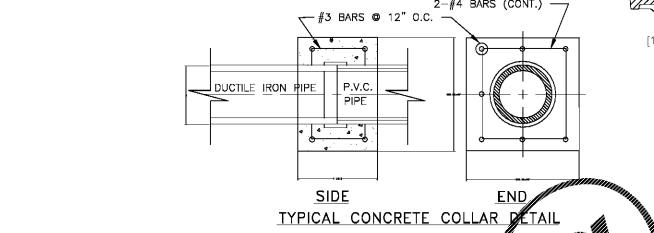
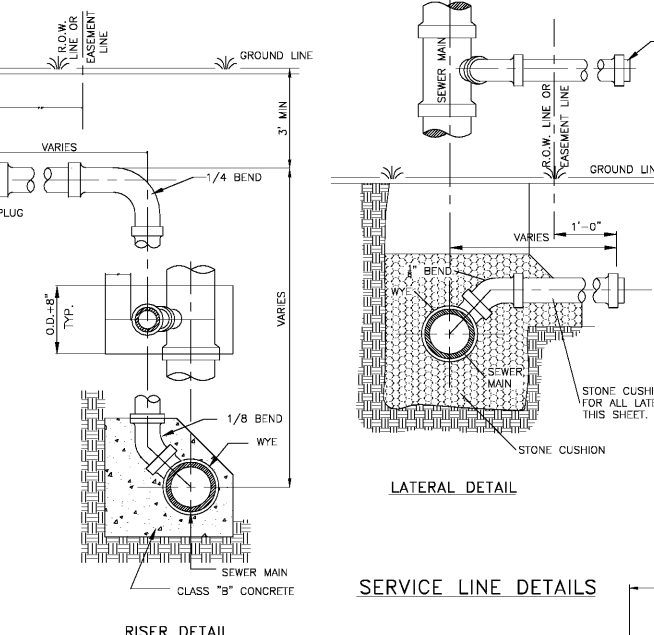
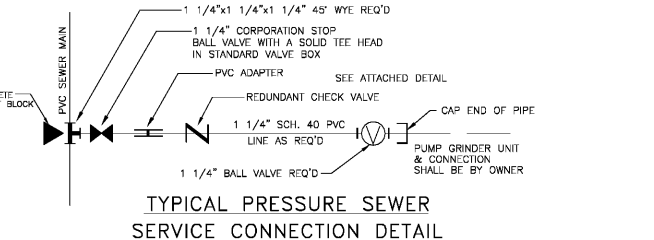
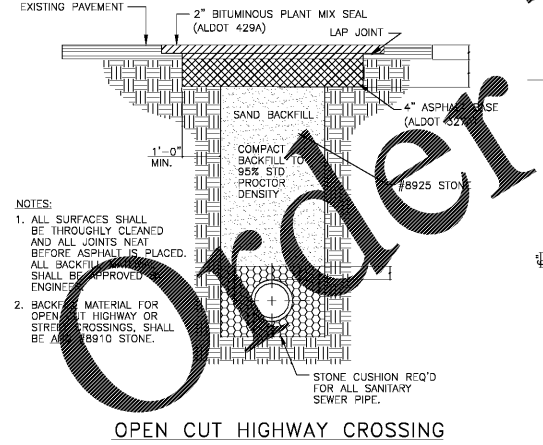
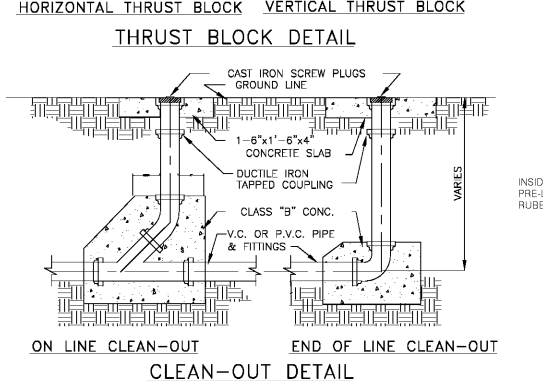
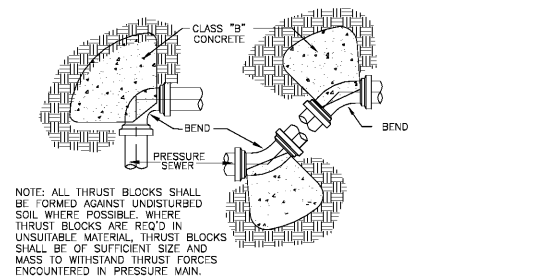
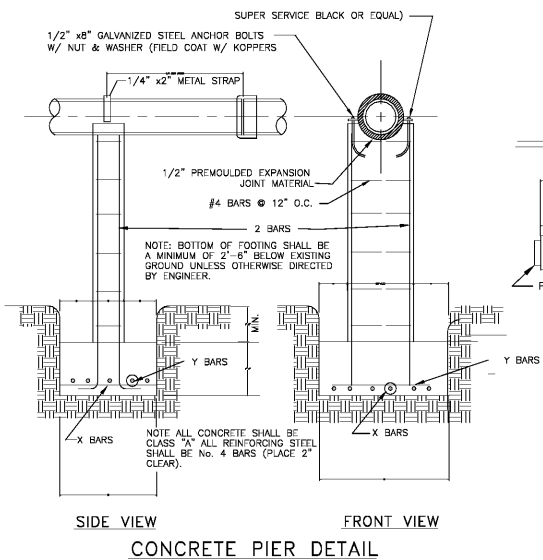

STANDARD SEWER DETAILS

File Name: n:\jess\XXXX-XX-XXX*.dwg

- NOTES:**
- ALL SURFACES SHALL BE THOROUGHLY CLEANED AND ALL JOINTS NEAT BEFORE ASPHALT IS PLACED. ALL BACKFILL SHALL BE APPROVED BY ENGINEER.
 - BACKFILL MATERIAL FOR OPEN CUT HIGHWAY OR STREET CROSSINGS, SHALL BE 3/4" MIN. STONE.

SENNELL
 CIVIL - STRUCTURAL - ENVIRONMENTAL - SURVEYING
 6336 Black Bears Way
 Tuscaloosa, AL 35401
 Phone: (205) 752-5564
 www.sennell.net

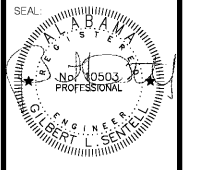

JEFFERSON COUNTY
 BRIGHTON COMMUNITY CENTER PROJECT
 BRIGHTON, ALABAMA 35020

NO.	DATE	DESCRIPTION
DRAWN:	GLS/KSP	
CHECKED:	GLS	
DATE:	7/30/18	
JOB NO.:	18-119	
SHEET:	C4	