

GENERAL NOTES - RCP

- SEE ELEC. DWGS. FOR ADDITIONAL LIGHTING INFORMATION.
- IN ROOMS WITH A SINGLE LIGHT, CENTER IN ROOM, U.N.O.
- ALL HEADERS IN SALES AREA TO BE WRAPPED WITH VVC U.N.O.
- SEE FINISH SCHEDULE FOR COLOR OF PAINT FOR EXPOSED DUCTS IN SALES AND SERVICE.
- EXTEND FINISH ABOVE ALL LINTELS / HEADERS TO DECK ABOVE IN AREAS WITH EXPOSED STRUCTURE OR TO 6" ABOVE FINISHED CEILING.
- COORDINATE ALL EXIT SIGN LOCATIONS AND MOUNTING HEIGHTS W/ LOCAL FIRE MARSHAL.
- GC TO INSTALL ALL SUSPENDED LIGHTS PLUMB AND LEVEL AS DETAILED ON ELECTRICAL DRAWINGS.

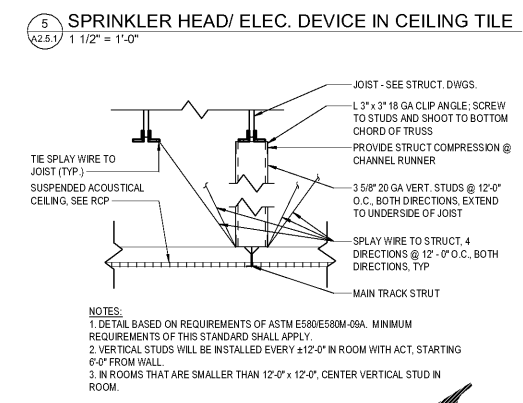
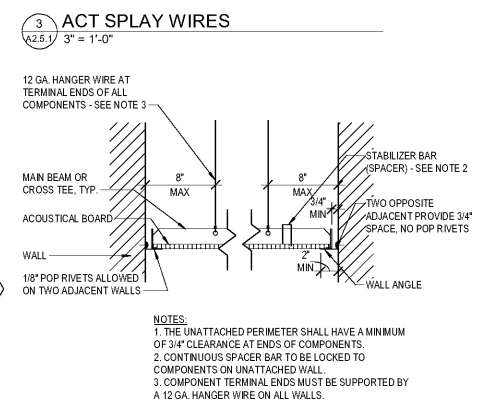

GENERAL NOTES - RCP

2 x 4 CEILING GRID - SEE FINISH SCHEDULE (ACT 1)

2 x 2 CEILING GRID - SEE FINISH SCHEDULE (ACT 2)

(X - X') CEILING HEIGHT ABOVE FINISHED FLOOR

- AR RETURN GRILLE OR EXHAUST GRILL
- SUPPLY AIR DIFFUSER
- 2 LIGHT FIXTURE
- 2 x 4 LIGHT FIXTURE
- FLUORESCENT LIGHTING (BACK OF HOUSE - SEE ELECTRICAL)
- 8 FT. FLUORESCENT LIGHT (BACK OF HOUSE AREA - SEE ELECTRICAL)
- RADIAN (WHERE APPLICABLE)

GENERAL NOTE

- SEE ELEC. DWGS. FOR ADDITIONAL LIGHTING INFORMATION. IN ROOMS WITH A SINGLE LIGHT, CENTER IN ROOM, U.N.O.
- ALL HEADERS IN SALES AREA TO BE WRAPPED WITH VVC U.N.O.
- SEE FINISH SCHEDULE FOR COLOR OF PAINT FOR EXPOSED DUCTS IN SALES AND SERVICE.
- EXTEND FINISH ABOVE ALL LINTELS / HEADERS TO DECK ABOVE IN AREAS WITH EXPOSED STRUCTURE OR TO 6" ABOVE FINISHED CEILING.
- COORDINATE ALL EXIT SIGN LOCATIONS AND MOUNTING HEIGHTS W/ LOCAL FIRE MARSHAL.
- GC TO INSTALL ALL SUSPENDED LIGHTS PLUMB AND LEVEL AS DETAILED ON ELECTRICAL DRAWINGS.

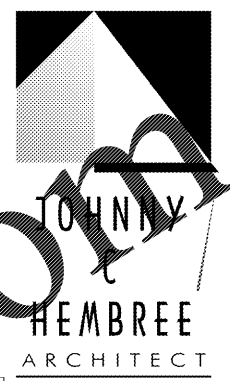
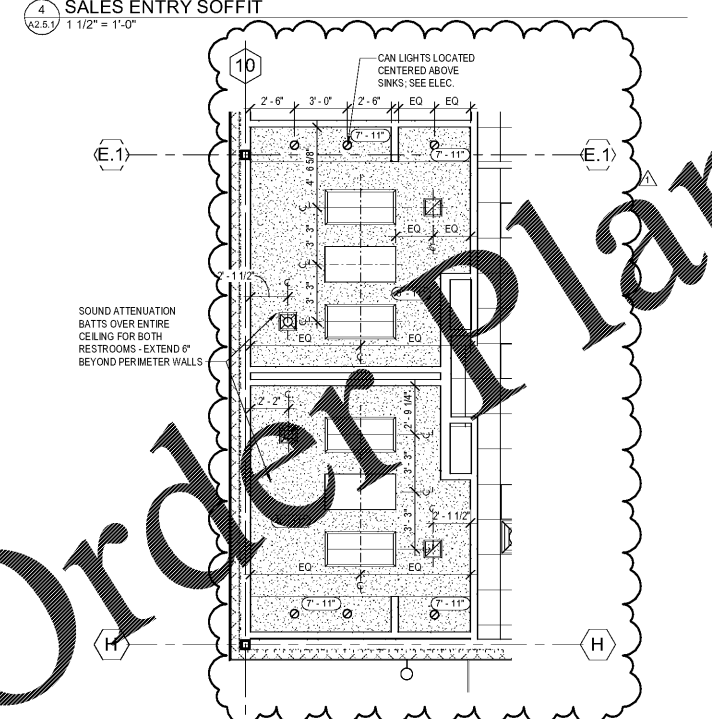
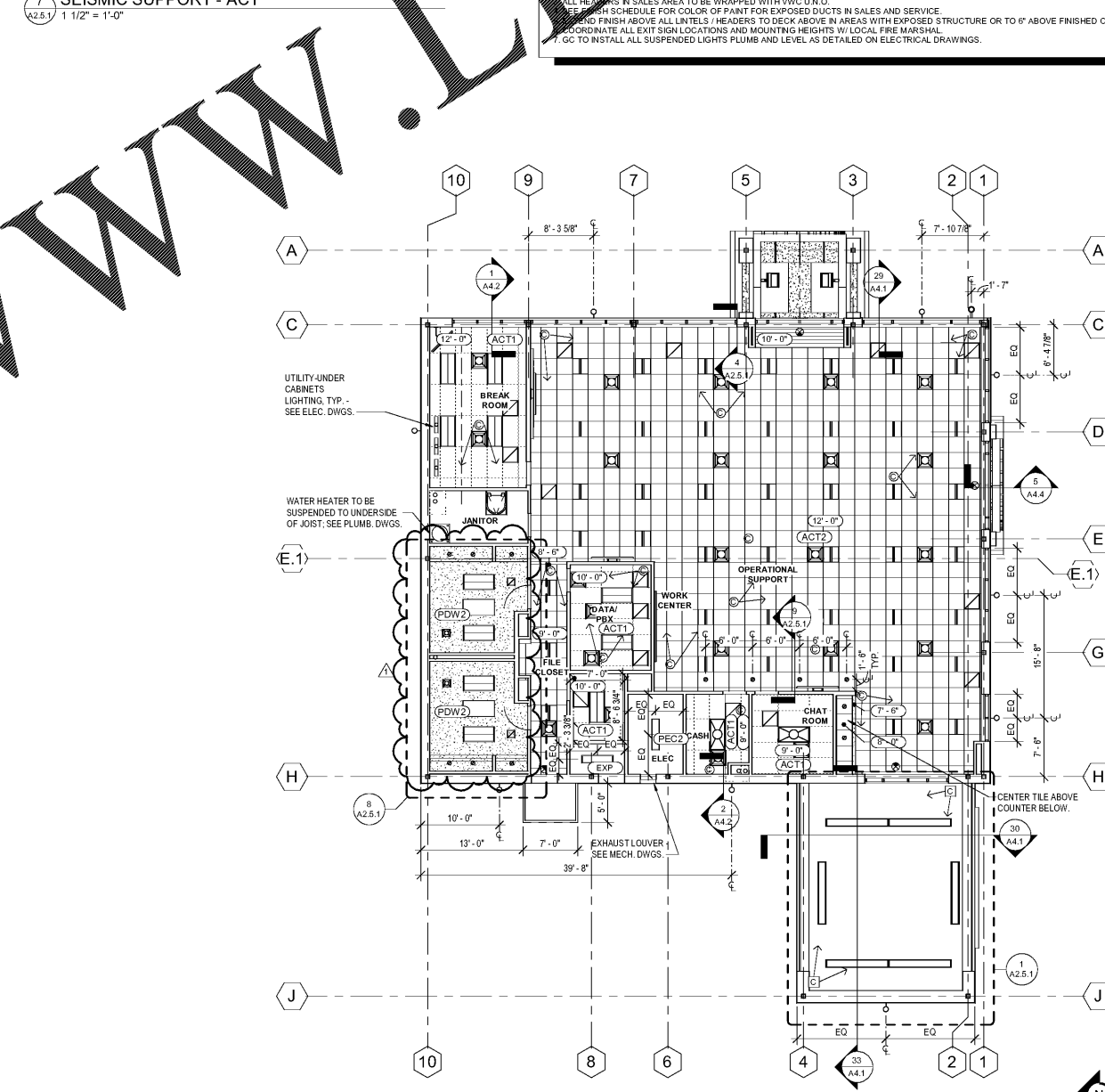
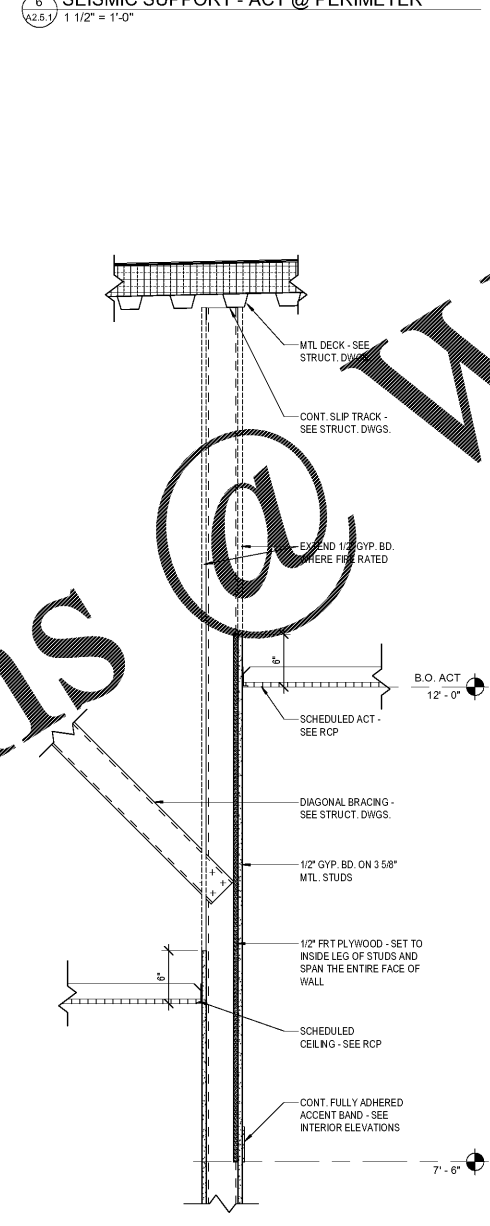
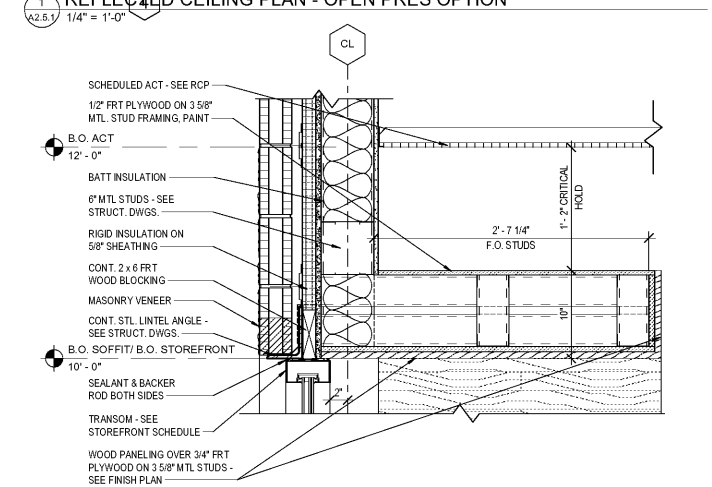

100%/PERMIT DOCUMENTS
XF2 SALES

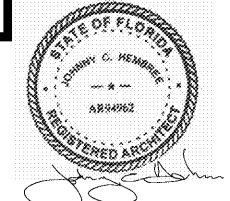

RELEASED FOR CONSTRUCTION

LATEST DATE: DA18-038R/ PC18-031

DRAWN BY: CNB

CHECKED BY: SCS

REV#	DATE	DESCRIPTION	BY
1	11/14/18	100% PERMIT DOCUMENTS	
1	2/12/19	PERMIT COMMENTS	AJM

CARMAX
THE AUTO SUPERSTORE

STORE NO. 6103
5320 & 5400 14TH STREET WEST
BRADENTON, FL 34207

PROJECT NO. 20-17083.02
DATE 14 NOV 2018
SHEET TITLE

REFLECTED CEILING PLAN & DETAILS - SALES

SHEET NO. **A2.5.1**

2/12/2019 8:16:30 AM

Order Plans

WWW.LDLINE.COM