

1 S5.0 3/4" = 1'-0"
 Typical Steel Column Connection to Footing

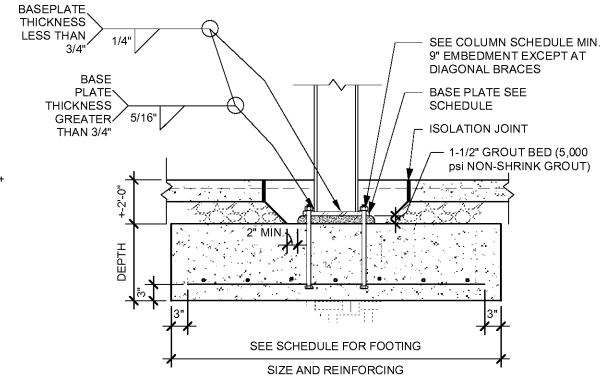

2 S5.0 3/4" = 1'-0"
 Typical Detail of Steel Column and Footing Where Footing is Up to 2'-0" Below Floor

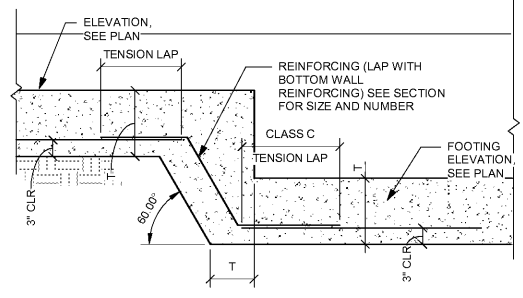

2 S5.0 3/4" = 1'-0"
 Typical Step in Footing

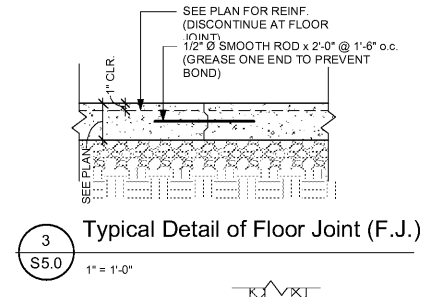

3 S5.0 1" = 1'-0"
 Typical Detail of Floor Joint (F.J.)

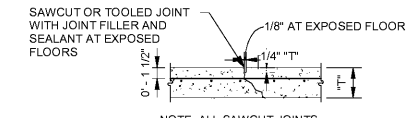

5 S5.0 1" = 1'-0"
 Typical Detail of Dummy Joint (D.J.)

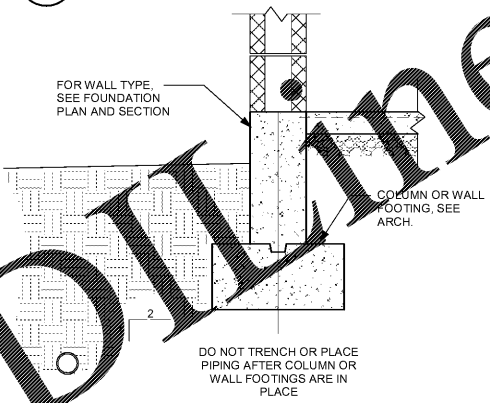

4 S5.0 1" = 1'-0"
 Typical Detail of Trenches Near Footings

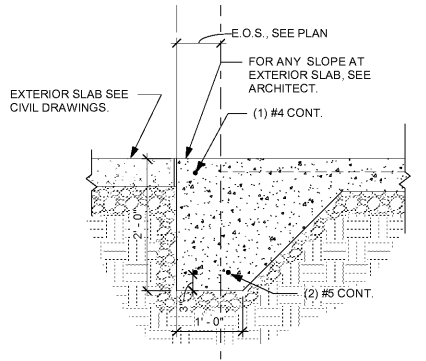

6 S5.0 3/4" = 1'-0"
 Typical Turndown (2'-0" x 1'-0")

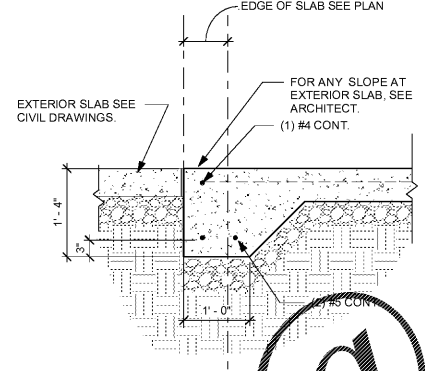

7 S5.0 3/4" = 1'-0"
 Typical Turndown (1'-4" x 1'-0")

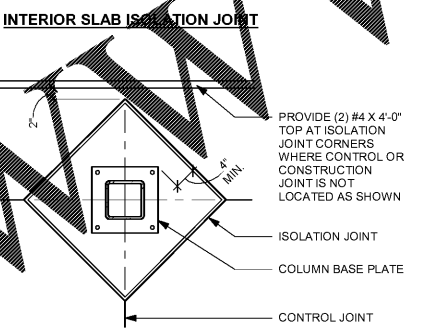

8 S5.0 3/4" = 1'-0"
 Typical Detail of Slab Isolation Joints

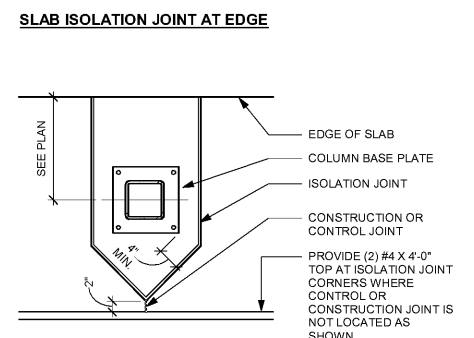
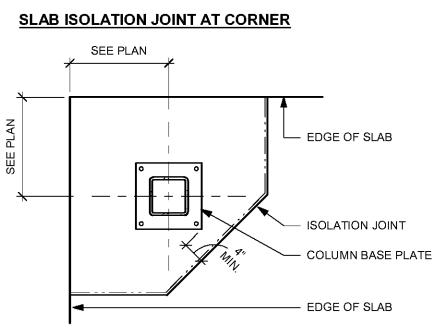

TYPICAL DETAIL OF CONTROL JOINT (C.J.) IN CONCRETE WALL

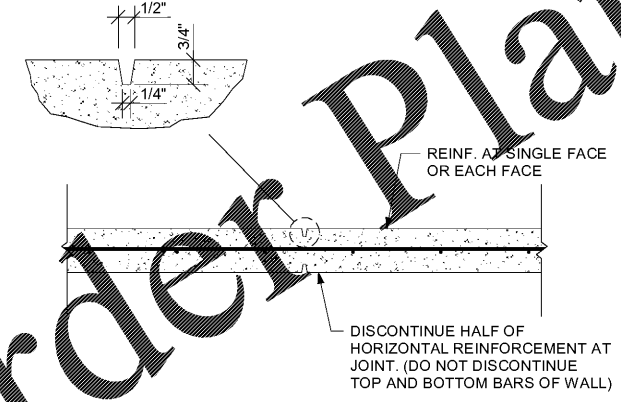

9 S5.0 3/4" = 1'-0"
 Typical Control Joints in Concrete Walls

PLAN @ EXPANSION JOINT

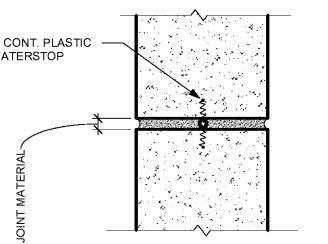

PROVIDE A 1" EXPANSION JOINT @ 60'-0" O.C. MAX. PROVIDE A CONT. PLASTIC VERT. WATERSTOP (8") AT EACH EXPANSION JOINT.

REVISIONS	NO.	DATE	COMMENTS
	01	15/19	Permit Set

RETAIL DEVELOPMENT
POP'S WINE & SPIRITS
 2-1764 TR A-B MCFARLAND 400 IND PARK
 MCFARLAND PKWY ALPHARETTA GA 30004

Typical Details (Foundation)
 PROJ. NO. 201812
 DATE: 01-15-19
 © 2019 ARCHPLAN DESIGN GROUP INC