

THE 4" PROJECTION ABOVE THE BOTTOM OF THE BASE PLATE IS A SUGGESTED MINIMUM TO ENSURE ADEQUATE ANCHOR ROD LENGTH. A DIFFERENT PROJECTION MAY BE REQUIRED BY THE FOUNDATION DESIGNER.

THE ANCHOR ROD PROJECTION MAY NEED TO BE CUT OFF IF THERE IS INTERFERENCE WITH OTHER PARTS.

SUGGESTED ANCHOR ROD PROJECTION

D1 (4) 1" Dia. GR36 Anchor Rods
 Plate W=1'-1" L=1'-5" (Maximum plate size)
 Elev.=100'-0"

D2 (4) 1" Dia. GR36 Anchor Rods
 Plate W=1'-1" L=1'-1" (Maximum plate size)
 Elev.=100'-0"

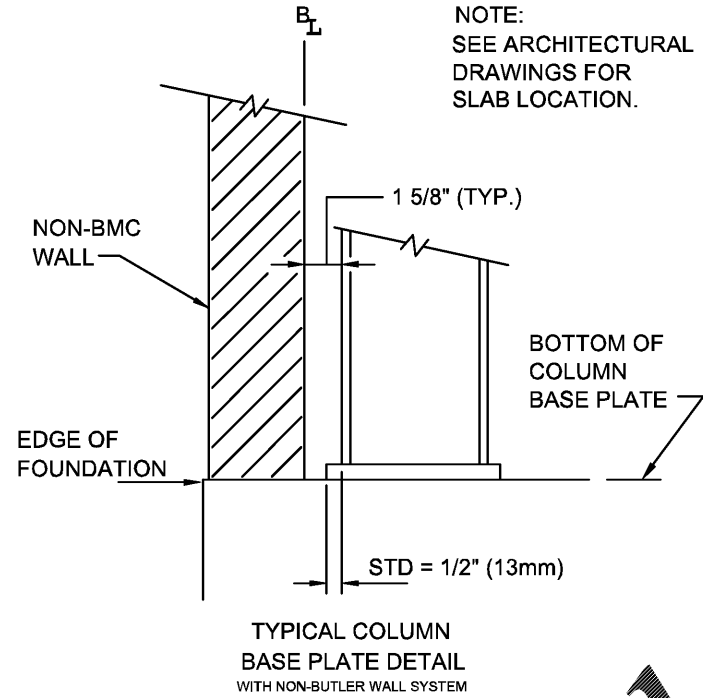

NOTE:
 SEE ARCHITECTURAL DRAWINGS FOR SLAB LOCATION.

1. ANCHOR RODS, NUTS, HARDENED WASHERS AND ANY OTHER EMBEDDED ITEMS ARE TO BE FURNISHED BY CONTRACTOR.
2. ANCHOR ROD DIAMETERS WERE DETERMINED BY ALLOWABLE SHEAR AND TENSION PER AISC SPECIFICATIONS (FY=36KSI). (ASTM F1554 GRADE 36) ANCHOR ROD LENGTH, EFFECTS OF EMBEDDED ANCHOR ROD EDGE DIMENSIONS AND METHOD OF TRANSFERRING FORCES FROM ANCHOR RODS TO FOOTINGS ARE TO BE DETERMINED BY OTHERS.
3. UNLESS OTHERWISE SPECIFIED, ANCHOR RODS ARE DESIGNED AND DETAILED AS "CAST-IN-PLACE" ANCHOR RODS WITH "SNUG TIGHT" CONNECTIONS.
4. FOUNDATION MUST BE LEVEL, SQUARE AND SMOOTH. ANCHOR RODS MUST BE ACCURATELY PLACED AS SHOWN ON THIS DRAWING OR STEEL WILL NOT FIT. THE BUILDER IS RESPONSIBLE FOR ACCURATE SETTING OF ANCHOR RODS PER AISC CODE OF STANDARD PRACTICE, SEC 7.5 VARIATIONS ARE SUMMARIZED BELOW:
 - a. CENTERS OF ANY TWO AR'S WITHIN A COLUMN BASE GROUP; +1/8"
 - b. CENTERS OF ADJACENT AR GROUPS; +1/4"
 - c. TOPS OF AR'S; +1/2"
 - d. ACCUMULATED DIM BETWEEN CENTERS OF AR GROUPS ALONG COLUMN LINE; +1/4" PER 100FT., NOT TO EXCEED 1" TOTAL
 - e. DIM FROM CENTER OF ANY AR GROUP FROM COLUMN LINE; +1/4"

DESIGN LOADS AND REACTIONS ARE FURNISHED IN THE REACTIONS REPORT.

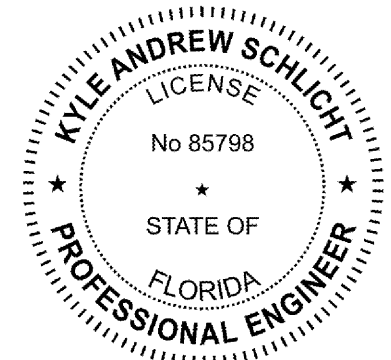

01/03/2019

DRAWING PREPARED BY:
 BUTLER MANUFACTURING, A DIVISION OF
 BLUESCOPE BUILDINGS NORTH AMERICA
 1540 GENESSEE STREET
 KANSAS CITY, MO 64102
 FLORIDA CERTIFICATE OF AUTHORIZATION
 NUMBER 30427

KYLE ANDREW SCHLICHT
 1540 GENESSEE STREET
 KANSAS CITY, MO 64102
 FLORIDA, PE #85798

Finished Floor Elevation = 100'-0" (Unless Noted Otherwise)

FOR CONSTRUCTION

THE BUILDING IS DESIGNED WITH BRACING DIAGONALS IN THE DESIGNATED BAYS. COLUMN BASE REACTIONS, BASE PLATES AND ANCHOR RODS ARE AFFECTED BY THIS BRACING AND DIAGONALS MAY NOT BE RELOCATED WITHOUT CONSULTING THE BUILDING SUPPLIERS ENGINEER.

THE BUTLER MFG. ENGINEER'S SEAL APPLIES ONLY TO THE WORK PRODUCT OF BUTLER MFG. AND DESIGN AND PERFORMANCE REQUIREMENTS SPECIFIED BY BUTLER. THE BUTLER MFG. ENGINEER'S SEAL DOES NOT APPLY TO THE PERFORMANCE OR DESIGN OF ANY OTHER PRODUCT OR COMPONENT FURNISHED BY BUTLER EXCEPT TO ANY DESIGN OR PERFORMANCE REQUIREMENTS SPECIFIED BY BUTLER.

THIS DRAWING, INCLUDING THE INFORMATION HEREON, REMAINS THE PROPERTY OF BUTLER MFG. IT IS PROVIDED SOLELY FOR ERECTING THE BUILDING DESCRIBED IN THE APPLICABLE PURCHASE ORDER AND MAY BE REPRODUCED ONLY FOR THAT PURPOSE. IT SHALL NOT BE MODIFIED, REPRODUCED OR USED FOR ANY OTHER PURPOSE WITHOUT PRIOR WRITTEN APPROVAL OF BUTLER MFG.

THE GENERAL CONTRACTOR AND/OR ERECTOR IS SOLELY RESPONSIBLE FOR ACCURATE GOOD QUALITY WORKMANSHIP IN ERECTING THIS BUILDING IN ACCORDANCE WITH THIS DRAWING, DETAILS REFERENCED IN THIS DRAWING, ALL APPLICABLE BUTLER MFG. ERECTION GUIDES, AND INDUSTRY STANDARDS PERTAINING TO PROPER ERECTION, INCLUDING THE CORRECT USE OF TEMPORARY BRACING.

B	BUTLER MANUFACTURING 1540 GENESSEE ST. KANSAS CITY, MO 64102		ANCHOR ROD PLAN	
	REV:	DATE:	BY:	DESCRIPTION:
DRAWING SCALE: NTS		BUILDER'S PDR: PM1	BUILDER: O'Reilly Automotive Stores, Inc.	CUSTOMER: O'Reilly Automotive Stores, Inc.
			LOCATION: Panama City, Florida	PROJECT: Panama City, FL (PM1)



JOB #: 18-047559-01
 DATE: 12/25/2018
 DRAWN/CHECK: JS / SW
 PAGE: 5