

**LANDSCAPE NOTES:**

- The Landscape Contractor shall be responsible for all materials and all work as called for on the Landscape Plans and in the Landscape Specifications. In the event of variation between quantities shown on plant list and the plans, the plans shall control. The Landscape Contractor shall verify all quantities and report any discrepancies at the time of bidding.
- The Landscape Contractor shall review architectural/engineering plans and become thoroughly familiar with surface and subsurface utilities.
- Prior to construction, the contractor shall be responsible for locating all underground utilities and shall avoid damage to all utilities during the course of the work. Locations of existing buried utility lines shown on the plans are based upon best available information and are considered to be approximate. It shall be the responsibility of the contractor 1) to verify the locations of utility lines within and adjacent to the work area 2) to protect all utility lines during the construction period 3) to repair any and all damage to utilities, structures, site appearances, etc. which occurs as a result of the construction 4) to field adjust the location of proposed trees and palms 10' off the center of the utility lines. Notify the Landscape Architect if a 10' offset does not function.
- The work shall be coordinated with other trades to prevent conflicts. Coordinate the planting with the irrigation work to assure availability and proper location of irrigation items and plants.
- Contractor shall ensure that there are no visual obstructions to vehicle lines of sight and traffic controls. Contractor shall field adjust tree and/or large shrub locations to avoid any such obstructions.
- Trees shall be maintained by the owner to avoid future such obstructions by pruning trees and/or shrubs as necessary utilizing horticulturally sound techniques.
- All planting shall be performed by personnel familiar with planting procedure and under the supervision of a qualified planting foreman.
- All plant material shall be graded Florida No. 1 or better as outlined under Grades and Standards for Nursery Stock, Part I and II, published by the Florida Department of Agriculture and Consumer Services.
- The minimum acceptable size of all plants, measured after pruning, with branches in normal positions, shall conform to the measurements shown on the drawings or as indicated on the landscape drawing. Height and spread dimensions refer to main body of the plant and not extreme branch tip to tip. Trunk caliper (trunk diameter) is measured 6 inches from the ground on trees up to and including 4 inches in caliper, and 12 inches from the ground for larger trees. Since trunks are seldom round, the average of the largest diameter and that perpendicular to it is referred to as caliper.
- The Landscape Architect or Owner shall have the right, at any stage of the operations, to reject any and all work and materials which, in his opinion, do not meet with the requirements of these specifications.
- Except as otherwise specified, the Landscape Contractor's work shall conform to accepted horticultural practices as used in the trade.
- Plants shall be protected upon arrival at the site, by being thoroughly watered and properly maintained until planted.
- TOPSOIL**  
Topsoil shall be natural, friable, fertile, fine loamy soil possessing characteristics of representative topsoil in the vicinity that produces heavy growth. Topsoil shall have a pH range of 5.5 to 7.4, free from subsoil, objectionable weeds, litter, sods, stiff clay, stones larger than 1 inch in diameter, stumps, roots, or any other material which may be harmful to plant growth or hinder planting operations. Top soil shall contain a minimum of three percent organic material. 6" Top Soil shall be placed in all turf & landscape areas.
- All tree pits shall be excavated to size and depth in accordance with the Florida Grades & Standards for Nursery Stock, unless shown otherwise on the drawings, and backfilled with the specified planting soil. The Landscape Contractor shall test fill all tree pits with water before planting to assure proper drainage percolation is available.
- The Landscape Contractor shall be responsible for proper watering of all plants. All plants shall be thoroughly watered at time of planting and kept adequately watered for plants to thrive as defined by Florida Grades and Standards for Nursery stock until time of acceptance. It shall be the Landscape Contractor's responsibility to assure that plants are not over watered.
- It shall be the Landscape Contractor's responsibility to prevent plants from falling or being blown over, to re-straighten and replant all plants which lean or fall and to replace all plants which are damaged due to lack of proper guying or staking. The Landscape Contractor shall be legally liable for any damage caused by instability of any plant material.
- All Palms to be staked as indicated per Palm Staking details. All other trees to be stabilized utilizing 8" lodge poles per tree planting details.
- Plants blown over by high winds, within the guaranteed period, shall not be cause for additional expense to the Owner, but shall be the responsibility of the Landscape Contractor. Damaged plants shall be replaced by the Landscape Contractor at no additional cost to the Owner.
- Sod shall be of a species specified on the drawings and originate from a commercial turf grower. It shall be a dense stand of live turf, reasonably free of weeds, well matted with grass roots in rectangles 12 inch by 24 inch or in 12 inch wide rolls in a length consistent with the equipment and methods used to handle the rolls and place the sod. Any netting contained within the sod shall be certified by the manufacturer to be biodegradable. The soil and root mat shall be a minimum of 1-1/2 inch thick and must hold together during placement and when roots, sods, or any other material which may be harmful to plant growth shall be staggered between the rows. Sod placed on slopes exceeding 3:1 shall be pinned with turf staples. Sod turf, shall have been mowed a minimum of one week prior to cutting and delivery, so that the length of the turf is no longer than 4 inches at time of delivery. Place sod within 48 hours of cutting the sod. The sod shall be kept moist throughout the 48 hour period to maintain the health and viability of the sod. Submit a letter of certification to the Owner's CEI Representative, at time of delivery, as to the source of the sod, the time it was cut, the species and cultivars provided, last mowing date, and that the sod is free of fire ants. Sod which has been cut for longer than 48 hours after being cut shall not be used unless specifically authorized by Owner's CEI Representative.
- It shall be the Contractor's responsibility to measure and determine the exact quantity of sod required for a complete job at the time of bidding or providing a price quote. The Owner shall not be responsible for additional cost due to the Contractor's under estimating of the quantity of sod for the original bid area.
- The Landscape Contractor shall insure adequate vertical drainage in all plant beds, planters, and sod areas. Vertical drilling through any compacted fill to native soil shall be accomplished to insure drainage. If well drained fill is necessary to assure positive drainage, this issue shall be brought up by the Landscape Contractor at time of bidding.
- UNSATURABLE SUBSOILS**  
Locations containing unsaturable subsoil shall be treated by one or more of the following:  
A. Where unsuitability is deemed by Owner or Owner's Representative to be due to excessive compaction caused by heavy equipment and where natural subsoil is other than AASHTO classification of A6 or A7, loosen such areas with spikes, dicing, or other means to loosen soil to condition acceptable to Owner. Loosen soil to minimum depth of 12 inches with additional loosening as required to obtain adequate drainage. Contractor may introduce peat, moss, sand, or organic matter into the subsoil to obtain adequate measures shall be considered as incidental, without additional cost to Owner.  
B. Where unsuitability is deemed by Owner or Owner's Representative to be due to presence of boards, mortar, concrete, graded aggregate base, or other construction materials in sub grade and where natural subsoil is other than AASHTO classification of A6 or A7, remove debris and objectionable material. Such remedial measures shall be considered as incidental, without additional cost to Owner.  
C. Where unsuitability is deemed by Owner to be because natural subsoil falls into AASHTO classification of A6 or A7 and contains moisture in excess of 30 percent, then installation of sub drainage system or other means described elsewhere in Specifications shall be used. Where such conditions have not been known or revealed prior to planting time and they have not been recognized in preparation of The Drawings and Specifications, then Owner shall issue pricing order to install proper remedial measures.  
D. Planting beds where existing subsoil is determined by Owner to be unsuitable for plant growth in accordance paragraph Unsaturable Subsoil herein shall be excavated to a depth of 12 inches or as needed to provide adequate drainage. Replace excavated soil with planting soil.
- The Landscape Contractor shall insure that his work does not interrupt established or projected drainage patterns.
- The Landscape Contractor shall prune, shape and remove dead foliage/limbs from existing plant material to remain consistent with the Landscape Architect or Owner the extent of work required at time of bidding.
- Stone - All plant beds shall be top dressed with river rock at 3" depth over a 10 mil thickness weed barrier. Approved equal River rock to be 2" to 1 1/2" diameter stone. A 4" diameter ring of river rock is to be placed around all trees not adjacent to a plant bed.
- Transplant Material - The Landscape Contractor shall be responsible for determining and evaluating which plant material is suitable for transplanting and shall verify this with the Landscape Architect or Owner. The Landscape Contractor shall take all reasonable, horticultural measures to assure the successful transplanting of determined plant material. The Landscape Contractor shall be responsible for replacing any relocated plant materials which die if such measures are not taken, as determined by the Landscape Architect or Owner. Replacement plants shall be of identical species and size if required.
- MAINTENANCE PRIOR TO FINAL INSPECTION AND ACCEPTANCE:**  
Maintenance shall commence after each plant is planted and the maintenance period shall continue until the job or specific phase of the job is accepted by the Landscape Architect or Owner. Extreme care shall be taken to protect the Owner or his representatives in general maintenance process.  
Plant maintenance shall include watering, pruning, fertilizing, mulching, staking, lighting, watering of guys, replacement of sick or dead plants, resetting plants to proper grades, right positioning and restoration of the planting saucer and all other care needed for proper growth of the plants.  
During the maintenance period and up to the time of final acceptance, the Landscape Contractor shall do all seasonal spraying and/or dusting of trees and shrubs. The completion of all plant maintenance and inspection for acceptance of work will be held. The Landscape Contractor shall notify the Landscape Architect or Owner of the scheduling of the inspection 10 days prior to the anticipated date.  
At the time of final inspection, if the materials are not in accordance with the specifications, a written notice will be given by the Landscape Architect or Owner to the Landscape Contractor stating the date when the Maintenance Period ends.
- WARRANTY AND REPLACEMENT:**  
All plant materials shall be guaranteed for one (1) year from the time of final inspection and interim acceptance shall be alive and in satisfactory growth for the specific kind of plant at the end of the guaranteed period.  
At the end of the guarantee period, any plant required under this contract that is dead or not in satisfactory growth, as determined by the Owner or the Landscape Architect, shall be removed and replaced. Replacement plants shall have an extended guarantee, as determined by the Owner or the Landscape Architect.  
All replacements shall be planted of the same kind and size as specified on the plant list. They shall be the responsibility of the Landscape Contractor.

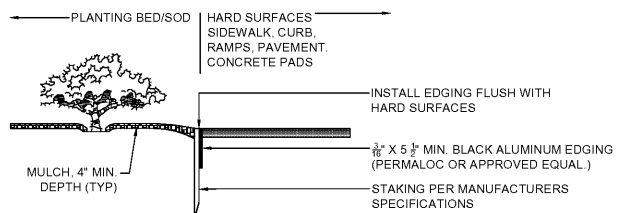

**ALUMINUM EDGING**  
N.T.S.

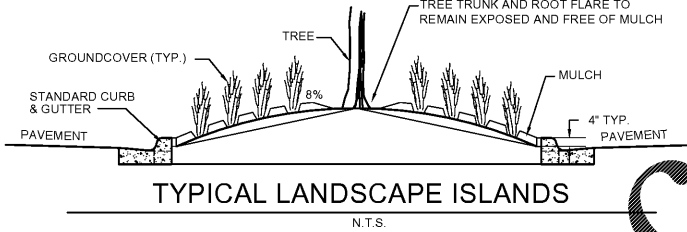
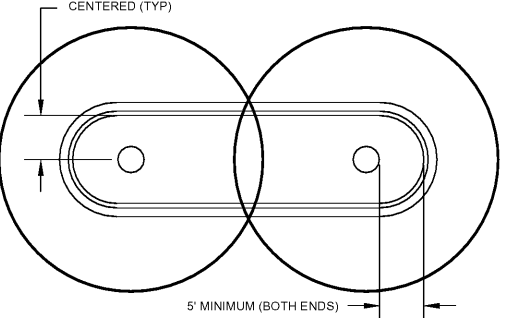
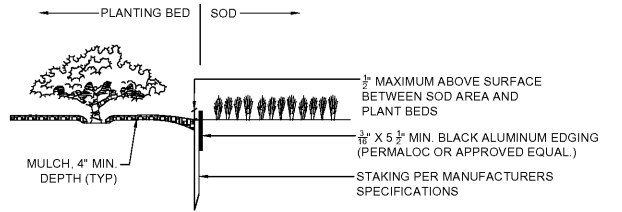
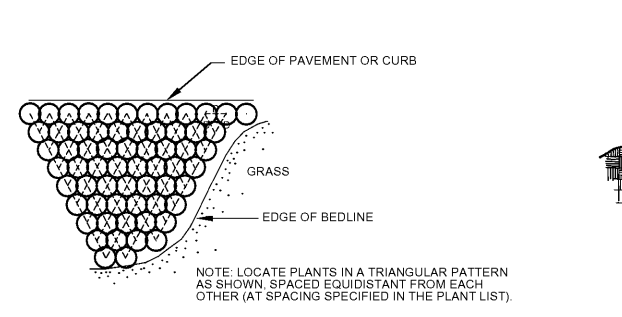

**SHRUB/GROUNDCOVER SPACING PLAN**  
N.T.S.

**TYPICAL ISLAND PLANTING**

ALL TREES PLANTED IN LANDSCAPE ISLANDS OR ANY LANDSCAPED AREAS SHOULD BE A MINIMUM OF 5' OFF OF BACK OF CURB UNLESS ABSOLUTELY NECESSARY DUE TO UTILITY LINES/PIPES LOCATION.

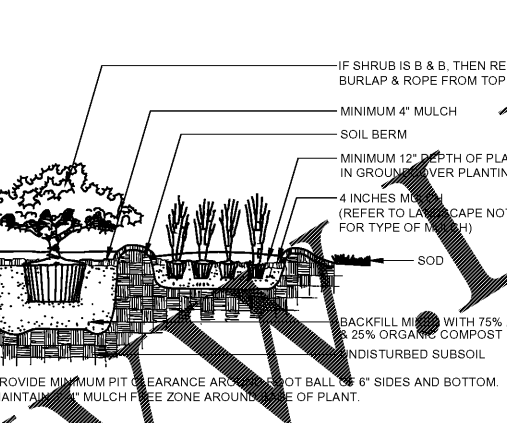

**SHRUB AND GROUNDCOVER PLANTING DETAIL**  
N.T.S.



**CONTAINER TREE PLANTING DETAIL**  
N.T.S.

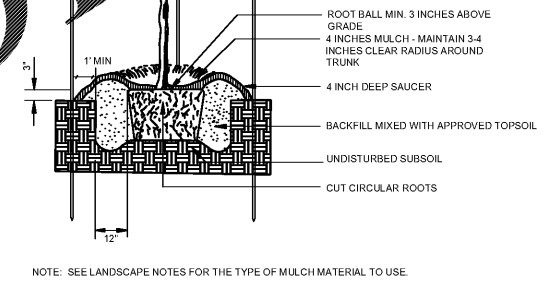

**TREE PLANTING @ TYPICAL SIGN**  
N.T.S.

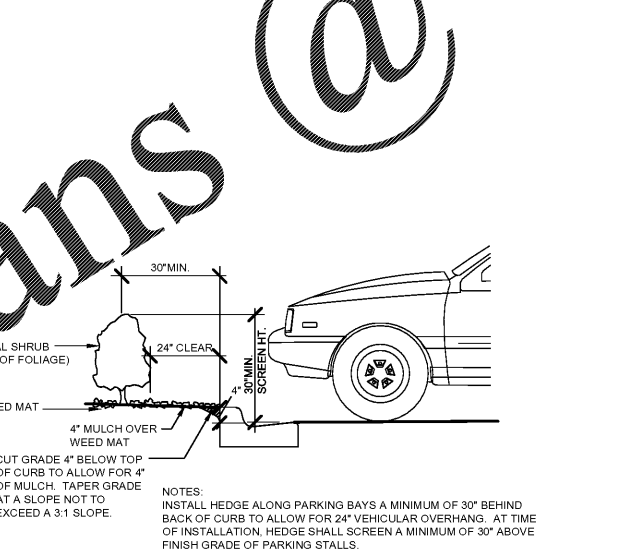

**TYPICAL SECTION - HEDGE INSTALLATION**  
N.T.S.

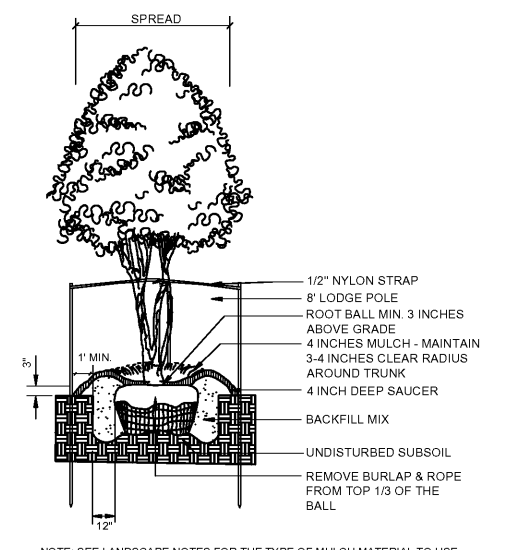

**MULTI-TRUNK B&B TREE PLANTING DETAIL**  
N.T.S.

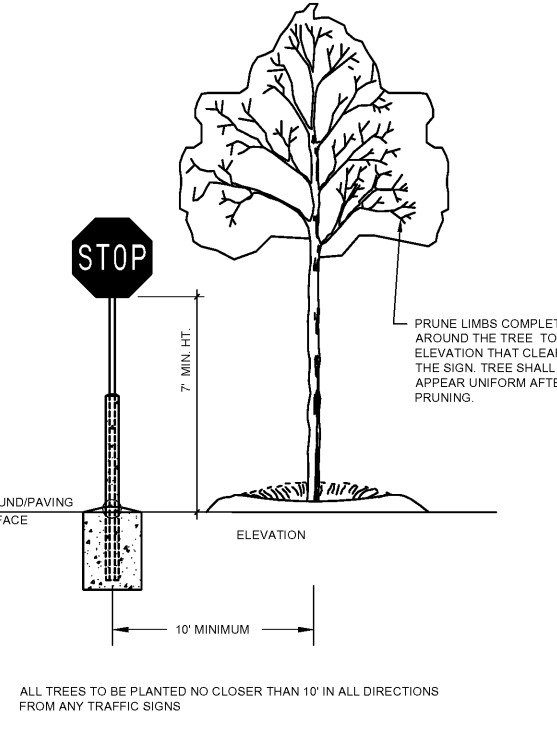

**TREE PLANTING @ TYPICAL SIGN**  
N.T.S.



PANDA RESTAURANT GROUP INC.  
1683 Walnut Grove Ave.  
Rosemead, California  
91770  
Telephone: 626.799.9898  
Facsimile: 626.372.8288

All ideas, designs, arrangement and plans indicated or represented by this drawing are the property of Panda Express Inc. and were created for use on this specific project. None of these ideas, designs, arrangements or plans may be used by or disclosed to any person, firm, or corporation without the written permission of Panda Express Inc.

**REVISIONS:**

NO.	DESCRIPTION

**ISSUE DATE:**

01/30/19	ISSUED FOR BID

DRAWN BY: B. Silcox

PANDA PROJECT # S8-19-D6573  
ARCH PROJECT # P7336.1

**gph** Plans Prepared By: GPH, Inc.  
5200 Balford Road, Suite 220  
Jacksonville, FL 32256  
Ph: 904.332.0959  
Licenses:  
Eng. C.O.A. No. 3215  
Survey L.B. No. 7143  
Arch. Lic. No. AA2800928  
Landscape Lic. No. LC0000938  
**A Full Service A & E Firm**

DANITA R. BRYANT, RLA  
LA6667318  
Jan 29, 2019

**PANDA EXPRESS**  
TRUE WARM & WELCOME 2200  
ATLANTIC & KERNAN  
CITY OF JACKSONVILLE, FLORIDA

**L2.0**

LANDSCAPE PLAN AND DETAILS

TRUE WARM & WELCOME 2200

Always call 811 two full business days before you dig  
**Sunshine811.com**  
www.sunshine811.com