

**1 EXHAUST/RETURN GRILLE CONNECTION DETAILS**  
M3.01 NOT TO SCALE

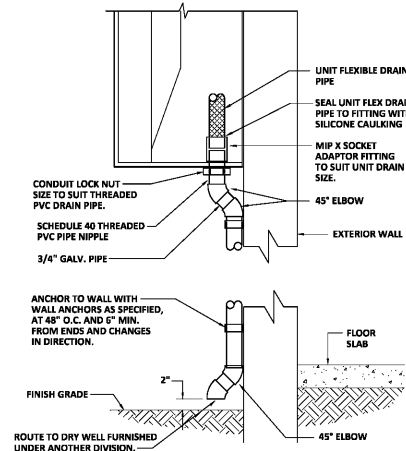

**2 WGU DRAIN DETAIL**  
M3.01 NOT TO SCALE

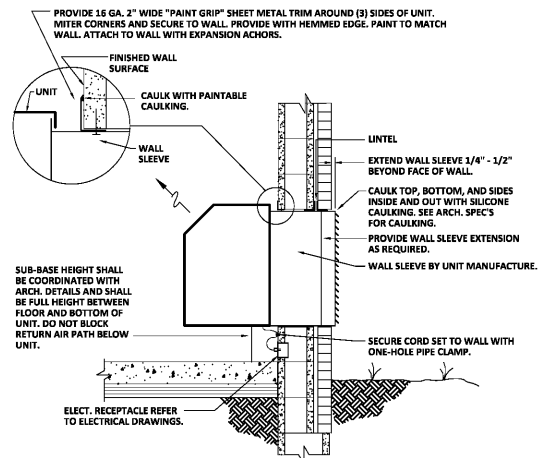

**3 THRU-THE-WALL UNIT DETAILS**  
M3.01 NOT TO SCALE

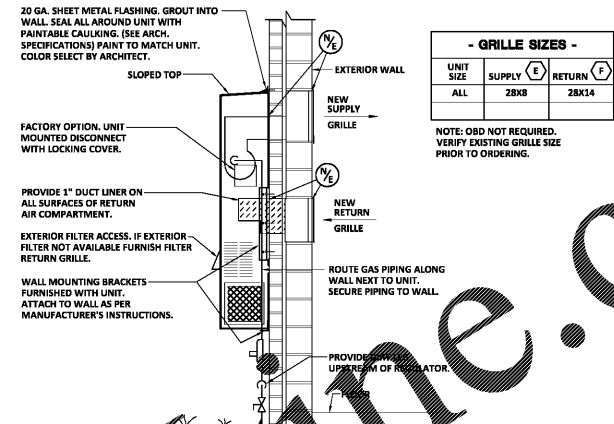

**4 WALL MOUNTED GAS-FIRED UNIT DETAIL**  
M3.01 NOT TO SCALE

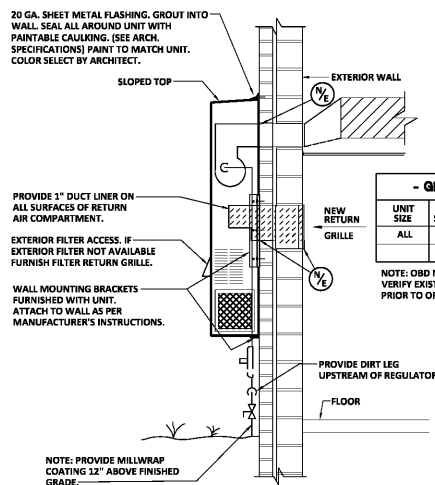

**5 WALL MOUNTED HEAT PUMP DETAIL**  
M3.01 NOT TO SCALE

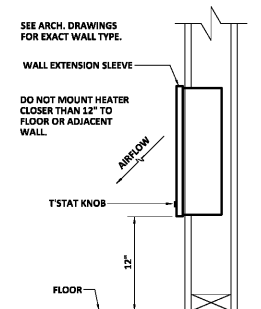

**6 ELECTRIC WALL HEATER DETAIL**  
M3.01 NOT TO SCALE

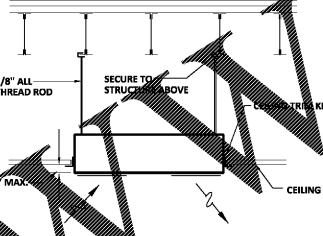

**7 CABINET HEATER DETAIL**  
M3.01 NOT TO SCALE

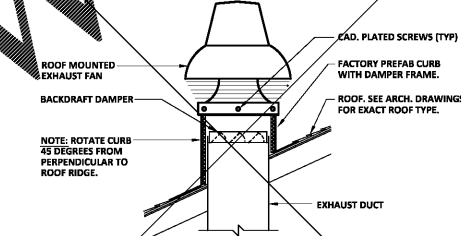

**8 NOT USED**  
M3.01 NOT TO SCALE

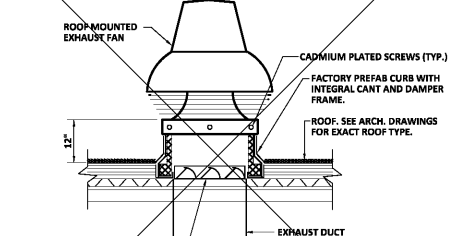

**9 NOT USED**  
M3.01 NOT TO SCALE

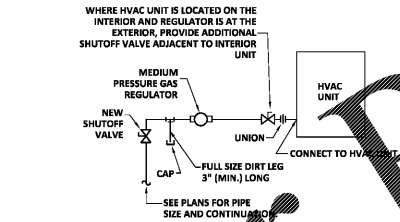

**10 GAS CONNECTION DETAIL**  
M3.01 NOT TO SCALE

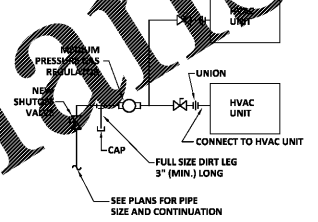

**11 MULTIPLE UNIT GAS CONNECTION DETAIL**  
M3.01 NOT TO SCALE

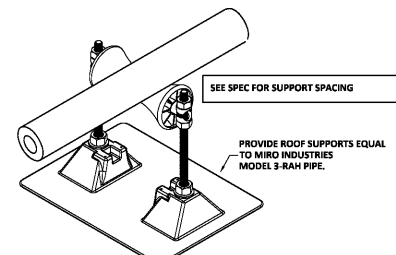

**12 ROOFTOP GAS PIPING SUPPORT**  
M3.01 SCHEMATIC

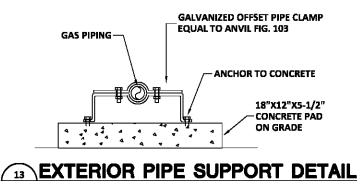

**13 EXTERIOR PIPE SUPPORT DETAIL**  
M3.01 NOT TO SCALE



**FRUETT, FORD & ASSOCIATES, INC.**  
CONSULTING ENGINEERS  
224 BROAD STREET, SUITE 3A  
AUGUSTA, GEORGIA 30601  
706/725-2888 • FAX 706/724-3207

THESE DOCUMENTS, OF SERVICE, REMAIN THE PROPERTY OF FRUETT, FORD & ASSOCIATES, INC. NO PART THEREOF MAY BE REPRODUCED OR USED IN ANY FORM WITHOUT WRITTEN PERMISSION.

DATE	
NO.	
REVISIONS	

CONSTRUCTION DOCUMENTS

HVAC DETAILS  
SCALE: 1/8" = 1'-0"  
SHEET  
**M3.01**  
16 OF 30  
FILE: 18\_04  
DATE: 12/14/18

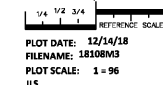

REFERENCE SCALE:  
PLOT DATE: 12/14/18  
FILENAME: 18108M3  
PLOT SCALE: 1 = 96  
JLS

Order Plans @

WWW.LDLINE.COM