

H2 LEASING #2 TYP
 D.608 SCALE: 1/2" = 1'-0"
 NOTE: ALL TRIM TO BE PAINTED P2.

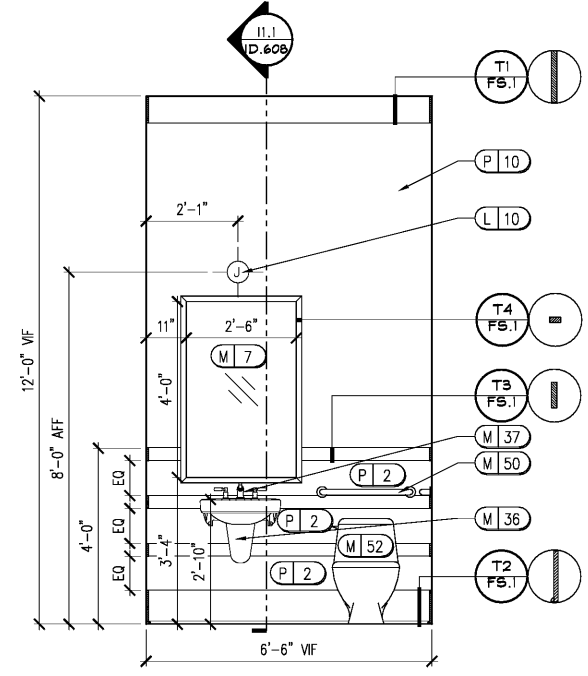

II POWDER
 D.608 SCALE: 1/2" = 1'-0"
 NOTE: 1. ALL TRIM TO BE PAINTED P2.
 2. WALL TO BE SMOOTH FINISH.

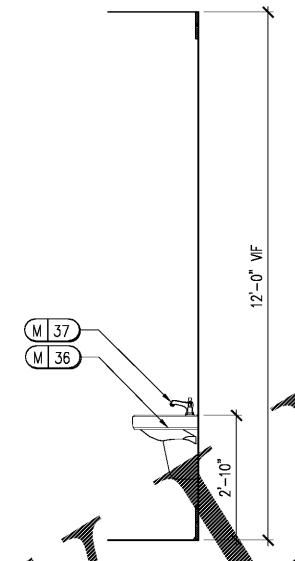

II.1 SECTION
 D.608 SCALE: 1/2" = 1'-0"

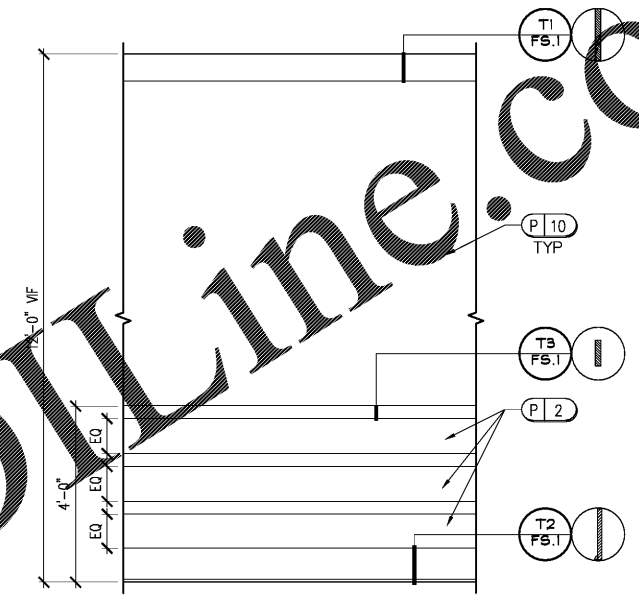

I2 POWDER TYP
 D.608 SCALE: 1/2" = 1'-0"
 NOTE: 1. ALL TRIM TO BE PAINTED P2.
 2. WALL TO BE SMOOTH FINISH.

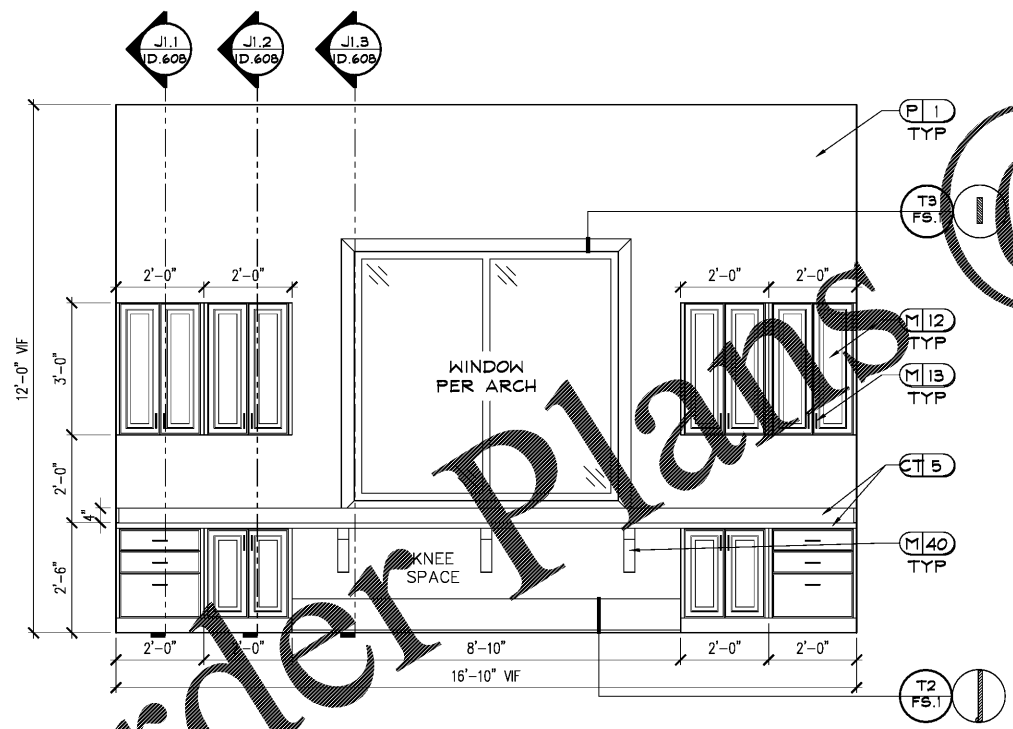

J1 WORK ROOM
 D.608 SCALE: 1/2" = 1'-0"
 NOTE: 1. ALL TRIM TO BE PAINTED P2.
 2. USE M40 FOR SUPPORT AS NEEDED.

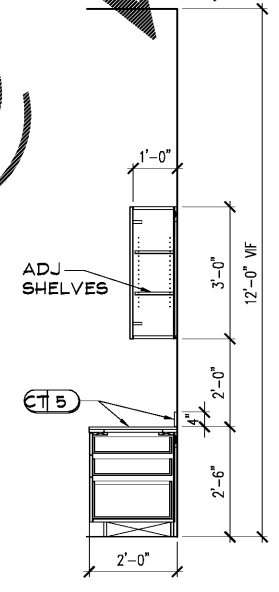

J1.1 SECTION
 D.608 SCALE: 1/2" = 1'-0"

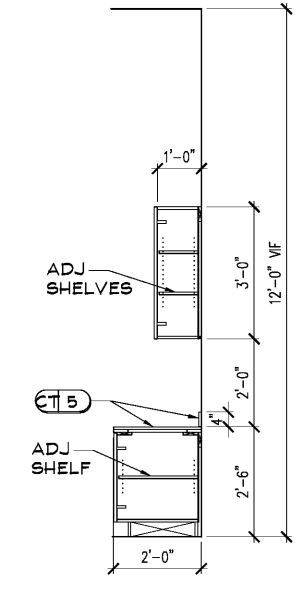

J1.2 SECTION
 D.608 SCALE: 1/2" = 1'-0"

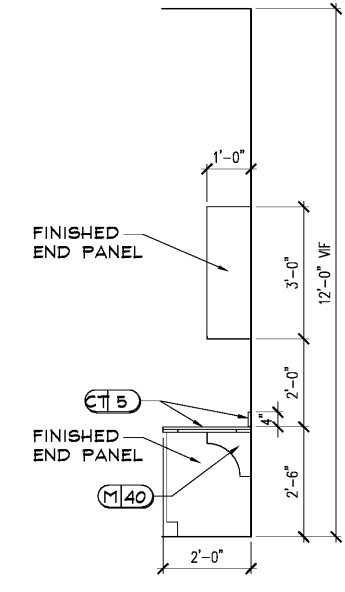

J1.3 SECTION
 D.608 SCALE: 1/2" = 1'-0"

Order Plans @ WWW.LDLine.com

DEI
 DESIGN ENVIRONMENTS INC.
 1000 GASTON AVENUE SUITE 200
 FARMINGDALE, NY 11735
 Phone: 770-429-2001
 Fax: 770-429-2002
 Email: info@deiinc.com

**LEASING/AMENITY @
 ALEXANDRIA
 HUNTSVILLE, AL
 BOBO FAMILY GROUP**

REV.	DATE	REVISIONS

RELEASED FOR CONSTRUCTION
 BEGIN DATE: 10/30/18
 RELEASE DATE: 12/28/18
 DESIGNER: NSQ
 CAD DESIGNER: WP
 REVIEWED BY: NSQ, WP, MS

JOB # : 18270
 TITLE: INTERIOR ELEVATIONS & DETAILS
 SHEET: **ID.608**