

F1 COLD STOR. TYP
 D.607 SCALE: 1/2" = 1'-0"
 NOTE: ALL TRIM TO BE PAINTED P2.

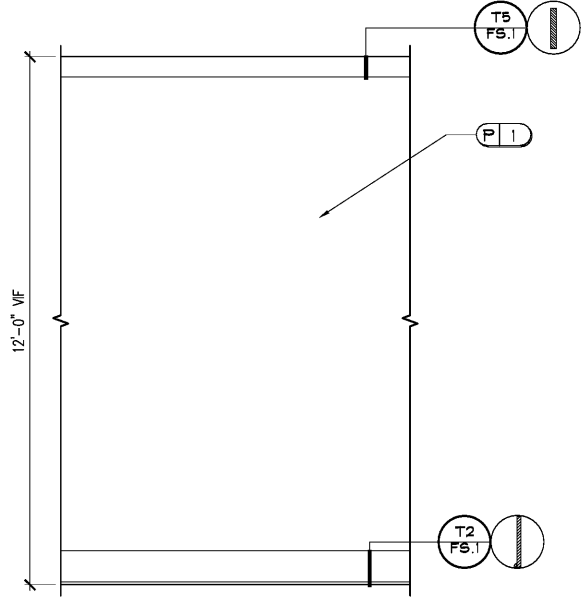

G1 CORR. TYP
 D.607 SCALE: 1/2" = 1'-0"
 NOTE: ALL TRIM TO BE PAINTED P2.

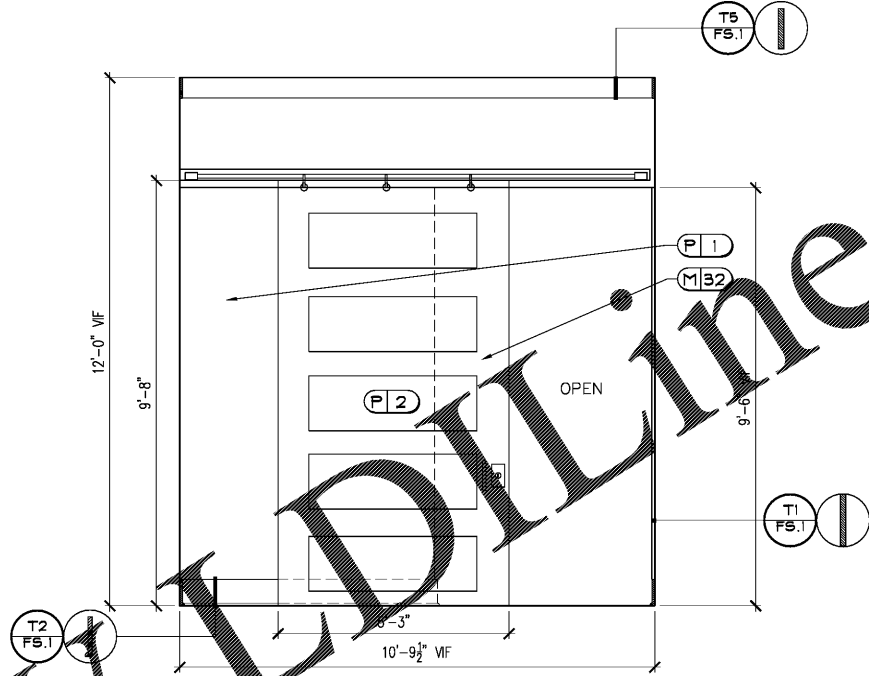

G2 CORR
 D.607 SCALE: 1/2" = 1'-0"
 NOTE: ALL TRIM TO BE PAINTED P2.

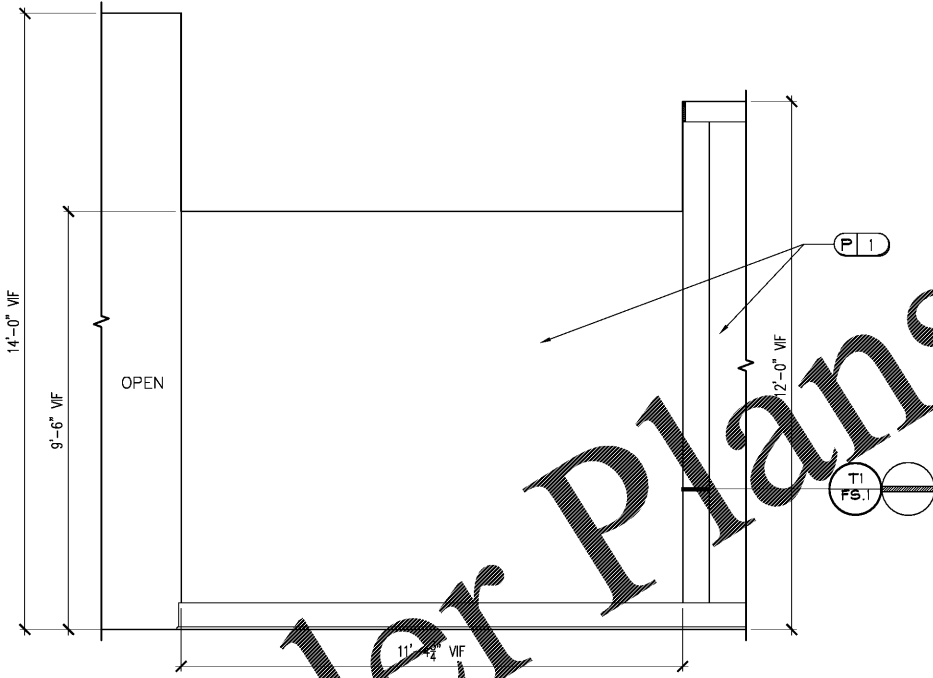

G3 CORR.
 D.607 SCALE: 1/2" = 1'-0"
 NOTE: ALL TRIM TO BE PAINTED P2.

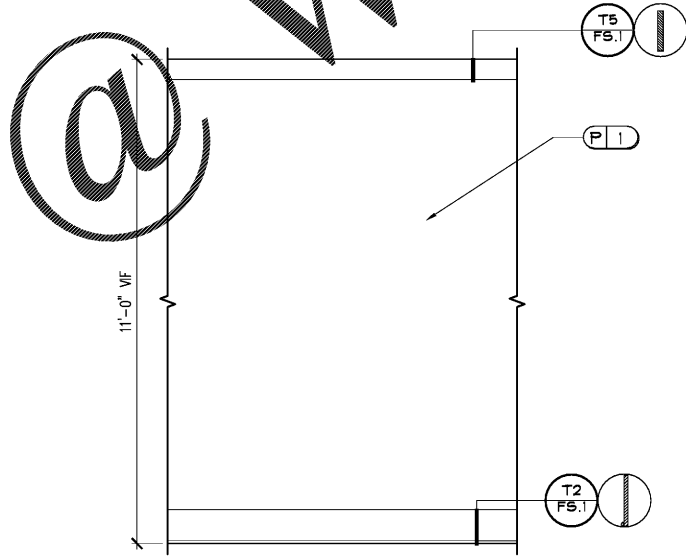

G4 CORR. TYP
 D.607 SCALE: 1/2" = 1'-0"
 NOTE: ALL TRIM TO BE PAINTED P2.

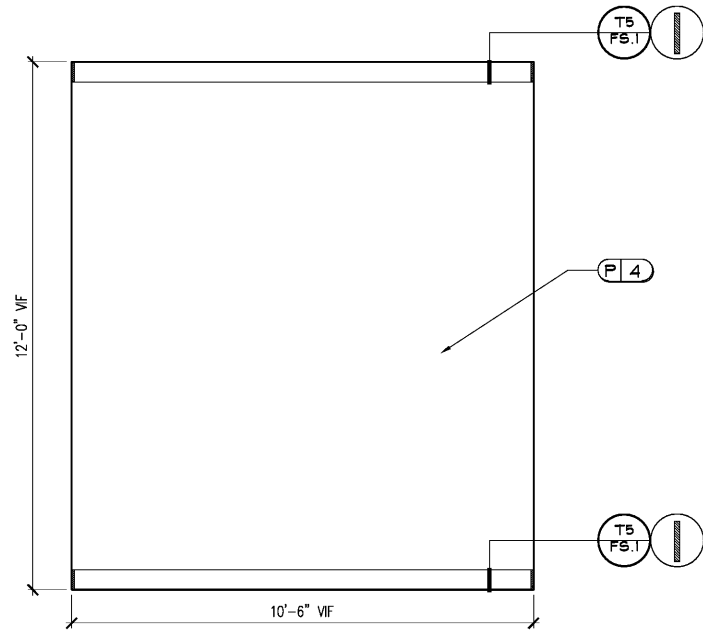

H1 LEASING #2
 D.607 SCALE: 1/2" = 1'-0"
 NOTE: ALL TRIM TO BE PAINTED P2.

Order Plans

WWW.LDLINE.COM

DEI
 DESIGN ENVIRONMENTS INC.
 1000 GASTON AVENUE SUITE 200
 FARMERSVILLE, OHIO 43024
 Phone: 770-429-3001
 Fax: 770-429-3002
 Email: info@dei-environments.com

This Drawing is the property of Design Environments Inc. and shall not be used or reproduced without their written permission.

LEASING/AMENITY @
 ALEXANDRIA
 HUNTSVILLE, AL
 BOBO FAMILY GROUP

REV.	DATE	REMARKS

RELEASED FOR CONSTRUCTION
 BEGIN DATE: 10.30.18
 RELEASE DATE: 12.28.18
 DESIGNER: NSQ
 CAD DESIGNER: WP
 REVIEWED BY: NSQ, WP, MS

JOB #: 18270
 TITLE: INTERIOR ELEVATIONS & DETAILS
 SHEET: ID.607