

Order Plans @

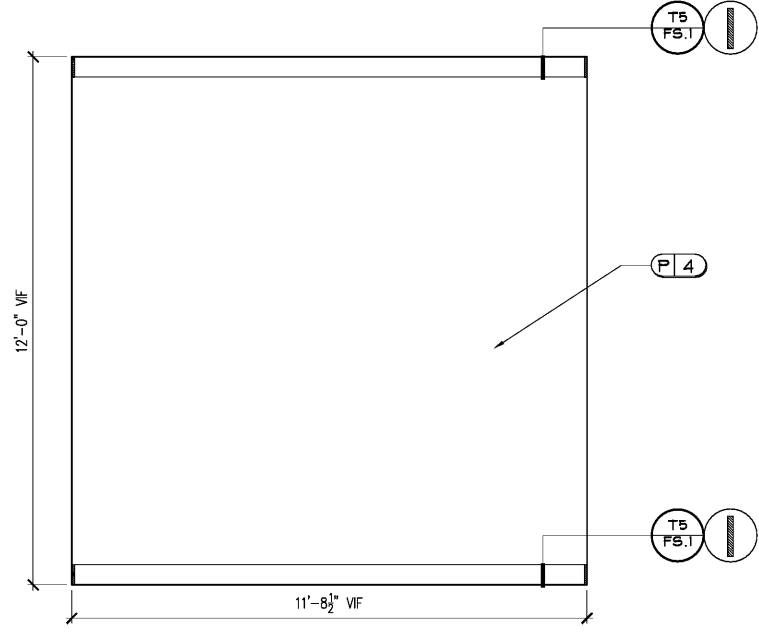

D1 MANAGER
 D.606 SCALE: 1/2" = 1'-0"
 NOTE: ALL TRIM TO BE PAINTED P2.

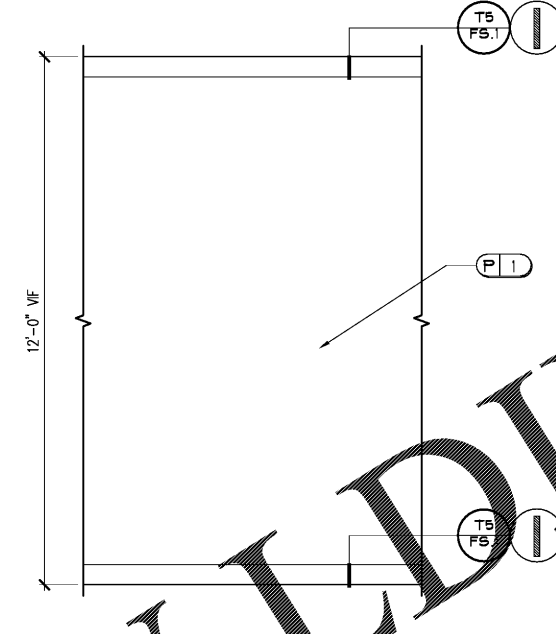

D2 MANAGER TYP
 D.606 SCALE: 1/2" = 1'-0"
 NOTE: ALL TRIM TO BE PAINTED P2.

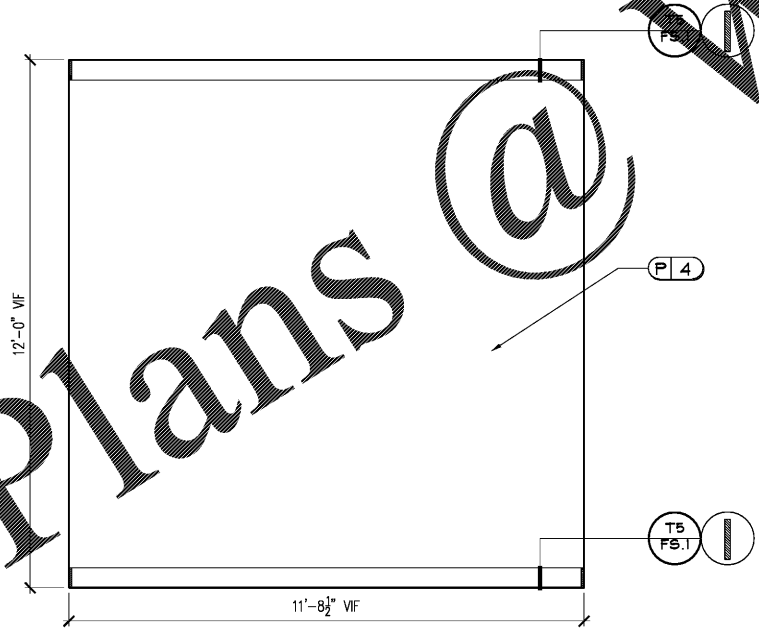

E1 LEASING #1
 D.606 SCALE: 1/2" = 1'-0"
 NOTE: ALL TRIM TO BE PAINTED P2.

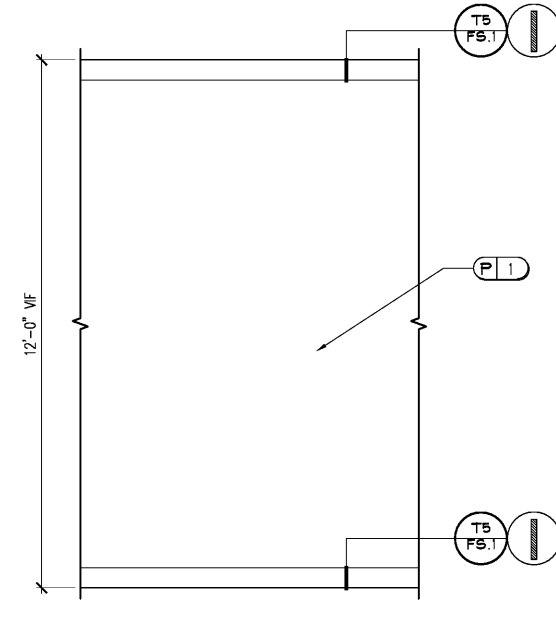

E2 LEASING #1 TYP
 D.606 SCALE: 1/2" = 1'-0"
 NOTE: ALL TRIM TO BE PAINTED P2.

DEI
 DESIGN ENVIRONMENTS INC.

Interior Design • Rendering
 100 EASTON AVENUE SUITE 200
 FARMINGTON, CT 06031
 Phone: 770-429-2001
 • E-MAIL: dei@designenvironments.com

This Drawing is the property of Design Environments Inc. and shall not be used or reproduced without their written permission.

LEASING/AMENITY @
 ALEXANDRIA
 HUNTSVILLE, AL
 BOBO FAMILY GROUP

DR.	REV.	DATE	REMARKS

RELEASED FOR CONSTRUCTION

BEGIN DATE: 10.30.18
 RELEASE DATE: 12.28.18
 DESIGNER: NSQ
 CAD DESIGNER: WP
 REVIEWED BY: NSQ, WP, MS

JOB #: 18270
 TITLE: INTERIOR ELEVATIONS & DETAILS
 SHEET: **ID.606**