

C4 CLUB BAR
ID.604 SCALE: 1/2" = 1'-0"

NOTE: 1. REFER TO ID.200A FOR LIGHTING LOCATIONS.
2. USE HIDDEN SUPPORT BRACKETS M4 AND M51 AS NEEDED FOR SUPPORT.
3. MITER ALL EDGES OF M18.

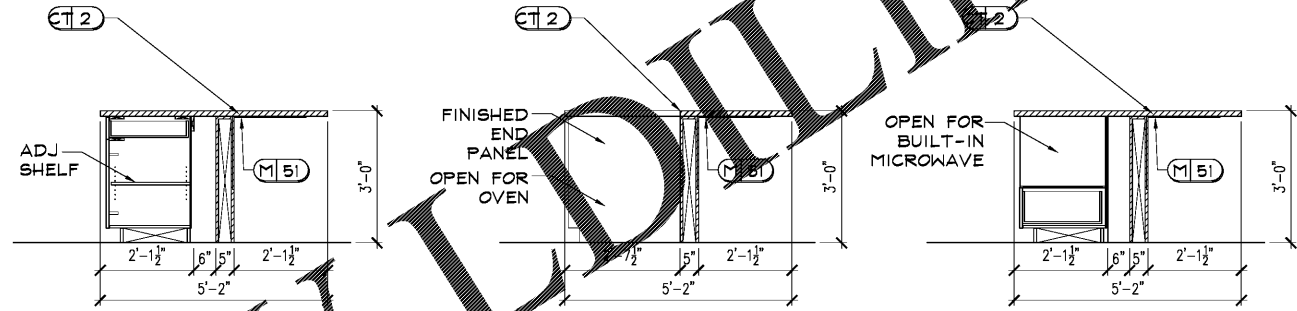

C4.1 SECTION
ID.604 SCALE: 1/2" = 1'-0"

C4.2 SECTION
ID.604 SCALE: 1/2" = 1'-0"

C4.3 SECTION
ID.604 SCALE: 1/2" = 1'-0"

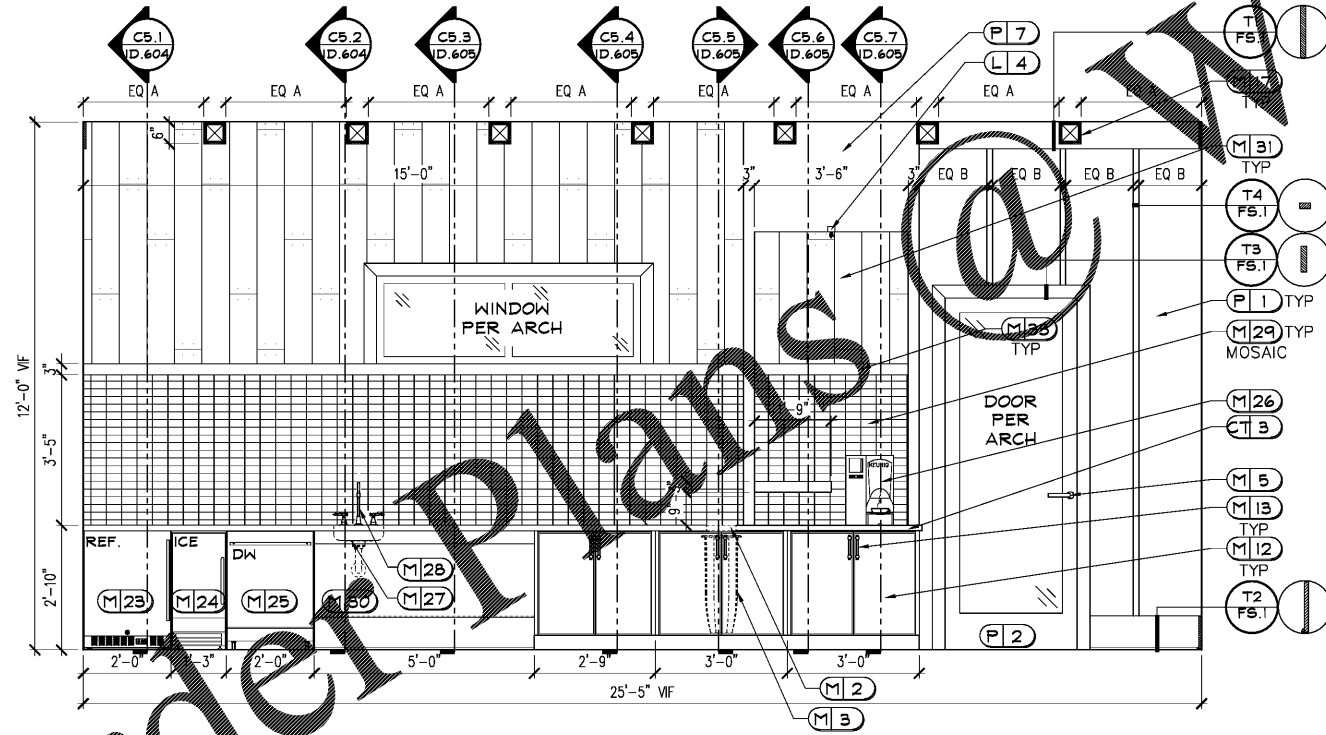

C5 CLUB BAR
ID.604 SCALE: 1/2" = 1'-0"

NOTE: 1. ALL TRIM TO BE PAINTED P2.
2. REFER TO ID.200A FOR LIGHTING LOCATIONS.
3. WALL TO BE SMOOTH FINISH.
4. MITER ALL EDGES OF M18 AND M33.
5. USE GREY OUTLET COVER M57 WHERE NEEDED.

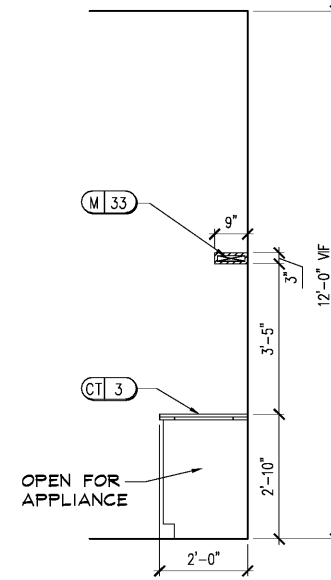

C5.1 SECTION
ID.604 SCALE: 1/2" = 1'-0"

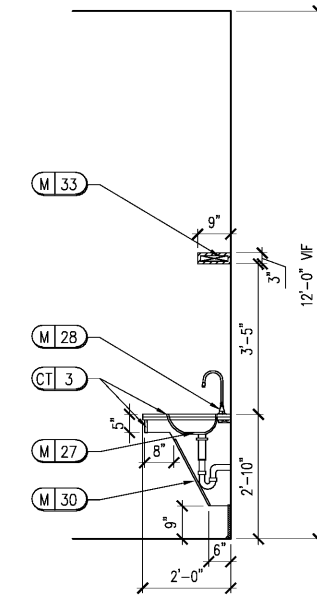

C5.2 SECTION
ID.604 SCALE: 1/2" = 1'-0"

DEI
DESIGN ENVIRONMENTS INC.

Interior Elevations • Rendering
100 GASTON AVENUE SUITE 200
FARMINGDALE, NY 11735
Phone: 770-429-4201
Fax: 770-429-4202
E-MAIL: dei@designenvironments.com

This Drawing is the property of Design Environments Inc. and is not to be used without their written permission.

LEASING/AMENITY @
ALEXANDRIA
HUNTSVILLE, AL
BOBO FAMILY GROUP

REV.	DATE	REMARKS

RELEASED FOR CONSTRUCTION
BEGIN DATE: 10/30/18
RELEASE DATE: 12/28/18
DESIGNER: NSQ
CAD DESIGNER: WP
REVIEWED BY: NSQ, WP, MS

JOB #: 18270
TITLE: INTERIOR ELEVATIONS & DETAILS
SHEET: ID.604

Order Plans @ WWW.LDOnline.com