

SPECIFICATIONS:
 AMERISTAR FENCING
 ECHELON II PANEL MAJESTIC 2R EXT 4" GAP 3"H 6"W
 1-888-333-3422

****NOTE:** WHEN USING SWIVEL BRACKETS ON EITHER OR BOTH ENDS OF A PANEL INSTALLATION CARE MUST BE TAKEN TO ENSURE THE SPACING BETWEEN POST AND ADJOINING PICKETS MEETS APPLICABLE CODES. THIS MAY REQUIRE TRIMMING ONE OR BOTH ENDS OF THE PANEL AS NEEDED.

POST NOTE: IN LOCATIONS SUBJECT TO FREEZING, WHERE POSTS ARE GROUTED INTO CORE-DRILLED HOLES, A 1/4" DIAMETER HOLE SHOULD BE DRILLED IN THE POST APPROXIMATELY 1/2" ABOVE ELEVATION TO ALLOW FOR DRAINAGE OF BUILT-UP GROUND WATER. THE DRILLED HOLE MUST BE WIPED CLEAN AND DRY AND SPRAYED WITH AMERISTAR ZINC RICH PRIMER AND AMERISTAR COLOR MATCH FINISH.

FROST LINE: FOOTER DEPTH SHOWN IS MINIMUM RECOMMENDATION. IN SOME CASES LOCAL RESTRICTIONS OF FREEZING WEATHER CONDITIONS MAY REQUIRE A GREATER DEPTH.

***PANEL RAKING:** DRAWING SHOWS FENCE PANEL AT LEVEL GROUND ELEVATION. FOR INSTALLATIONS THAT MUST BE RAKED TO FOLLOW SLOPING GRADES, THE POST SPACING DIMENSION SHOWN MUST BE MEASURED ALONG THE GRADE.

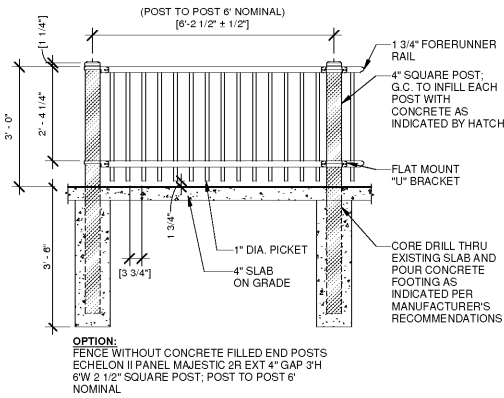

6 | PATIO RAILING DETAIL
 1/2" = 1'-0"

NOTE: FOOTING SIZE & REINFORCEMENT WILL VARY DEPENDING ON GEOGRAPHIC LOCATION. USE ONLY WHEN REQUIRED BY CODE(S).

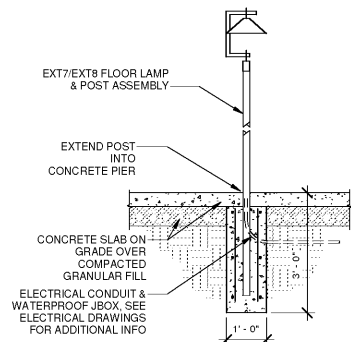

1 | LAMP BASE @ CONCRETE PATIO
 1/2" = 1'-0"

KEYED NOTES

- 0.06 PRIMARY BUILDING ENTRANCE.
- 0.09 GC TO PROVIDE MAXIMUM THRESHOLD HEIGHT OF 1/2".
- 0.11 CONCRETE PATIO; REFER TO SHEET A121 FOR ADDITIONAL INFORMATION.
- 0.12 PROPOSED CONCRETE SIDEWALK. PROVIDE BROOM FINISH PERPENDICULAR TO BUILDING. TYPICAL. REFER TO CIVIL DRAWINGS FOR ADDITIONAL INFORMATION.
- 0.13 ACCESSIBLE RAMP; REFER TO CIVIL DRAWINGS FOR ADDITIONAL INFORMATION AND DETAILS.
- 0.14 PROPOSED LANDSCAPE AREA. REFER TO LANDSCAPE DRAWINGS FOR ADDITIONAL INFORMATION TO UTILIZE LOCAL FLORA.
- 0.18 DRIVE THRU SIGNAGE. SEE SHEET A023 FOR FURTHER INFORMATION. ALSO SEE SHOP DRAWINGS.
- 0.21 PROPOSED ACCESSIBLE PARKING STALL. REFER TO CIVIL DRAWINGS FOR ADDITIONAL INFORMATION.
- 0.22 BOLLARD MOUNTED ACCESSIBLE SIGNAGE. MOUNT 2'-0" BACK FROM CURB FACE. REFER TO SHEET A002 FOR FURTHER INFORMATION.
- 0.23 PROPOSED PAINTED STRIPED CROSSWALK. REFER TO CIVIL DRAWINGS FOR ADDITIONAL INFORMATION.
- 0.30 PATIO RAILING BY PANEL. COLOR MATCH CHARCOAL REFER TO SHEET A040.
- 0.31 PATIO SIDEWALK. SET BY TERRAZZO. FLOOR TO BE DETECTED CEILING PLAN FOR FURTHER INFORMATION.
- 0.47 PANEL GC TO FINISH & INSTALL BICYCLE PARKING RACK.

LEGEND

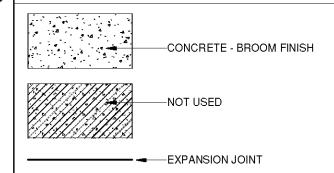

Bakery-Cafe:

#6119

SYSTEM: G4 (A) (A)

Project Title:

Professional Seal:

architect of record: William F. Arthur

License Number: AR0012074

Project Title:

10/30/2018 12:03:21 PM

10/30/2018 12:03:21 PM

10/30/2018 12:03:21 PM

10/30/2018 12:03:21 PM

10/30/2018 12:03:21 PM

10/30/2018 12:03:21 PM

10/30/2018 12:03:21 PM

10/30/2018 12:03:21 PM

10/30/2018 12:03:21 PM

10/30/2018 12:03:21 PM

10/30/2018 12:03:21 PM

10/30/2018 12:03:21 PM

10/30/2018 12:03:21 PM

10/30/2018 12:03:21 PM

10/30/2018 12:03:21 PM

10/30/2018 12:03:21 PM

10/30/2018 12:03:21 PM

10/30/2018 12:03:21 PM

10/30/2018 12:03:21 PM

10/30/2018 12:03:21 PM

10/30/2018 12:03:21 PM

10/30/2018 12:03:21 PM

10/30/2018 12:03:21 PM

10/30/2018 12:03:21 PM

10/30/2018 12:03:21 PM

10/30/2018 12:03:21 PM

10/30/2018 12:03:21 PM

10/30/2018 12:03:21 PM

10/30/2018 12:03:21 PM

10/30/2018 12:03:21 PM

10/30/2018 12:03:21 PM

10/30/2018 12:03:21 PM

10/30/2018 12:03:21 PM

10/30/2018 12:03:21 PM

10/30/2018 12:03:21 PM

10/30/2018 12:03:21 PM

10/30/2018 12:03:21 PM

10/30/2018 12:03:21 PM

10/30/2018 12:03:21 PM

10/30/2018 12:03:21 PM

10/30/2018 12:03:21 PM

10/30/2018 12:03:21 PM

10/30/2018 12:03:21 PM

10/30/2018 12:03:21 PM

10/30/2018 12:03:21 PM

10/30/2018 12:03:21 PM

10/30/2018 12:03:21 PM

10/30/2018 12:03:21 PM

10/30/2018 12:03:21 PM

10/30/2018 12:03:21 PM

10/30/2018 12:03:21 PM

10/30/2018 12:03:21 PM

10/30/2018 12:03:21 PM

10/30/2018 12:03:21 PM

10/30/2018 12:03:21 PM

10/30/2018 12:03:21 PM

10/30/2018 12:03:21 PM

10/30/2018 12:03:21 PM

10/30/2018 12:03:21 PM

10/30/2018 12:03:21 PM

10/30/2018 12:03:21 PM

10/30/2018 12:03:21 PM

10/30/2018 12:03:21 PM

10/30/2018 12:03:21 PM

10/30/2018 12:03:21 PM

10/30/2018 12:03:21 PM

10/30/2018 12:03:21 PM

10/30/2018 12:03:21 PM

CONSTRUCTION DRAWINGS

Bakery Cafe #6119
 6351 MANATEE AVE W,
 BRADENTON, FL 34209

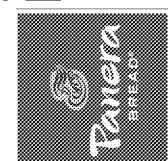

These plans and specifications are the exclusive property of WFA Design. Any reproduction, modification, distribution, and/or use of these materials (or any portion thereof) without WFA Design's prior written consent is strictly prohibited.

No.	Description	Date

ENLARGED PATIO PLAN

Project Number: #6119
 Sheet Number: A040
 Drawn By: MMH/NH
 Issue Date: 09.30.18
 DPM: J.R. DM: D.C. CPM: R.K.

DO NOT ENTER
 ↑

WWW.LDILLINE.COM

Order Plans

2 | SIDEWALK PLAN
 1/4" = 1'-0"