

Order Plans @

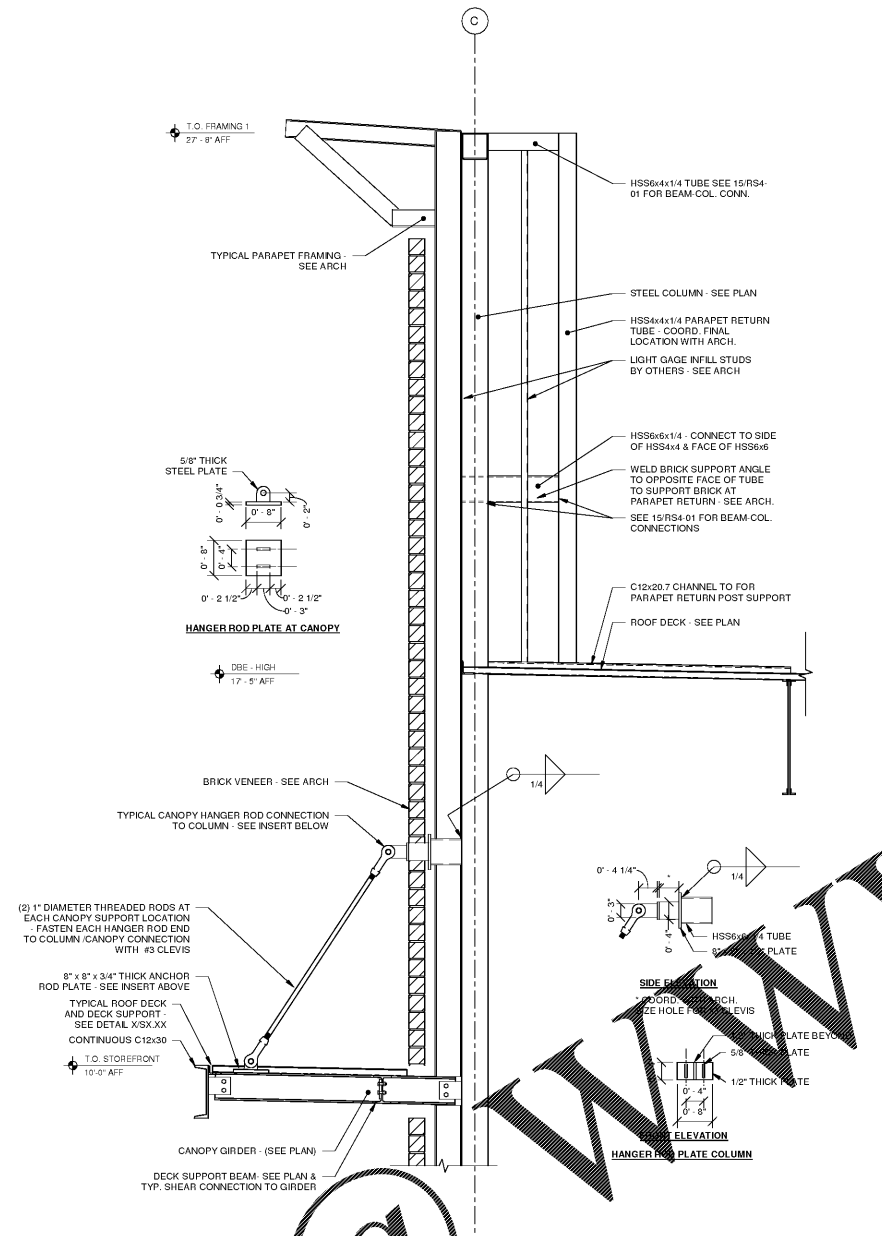

1 SECTION AT LOW PARAPET PILASTER CONNECTION
RS5-02 SCALE: 3/4" = 1'-0"

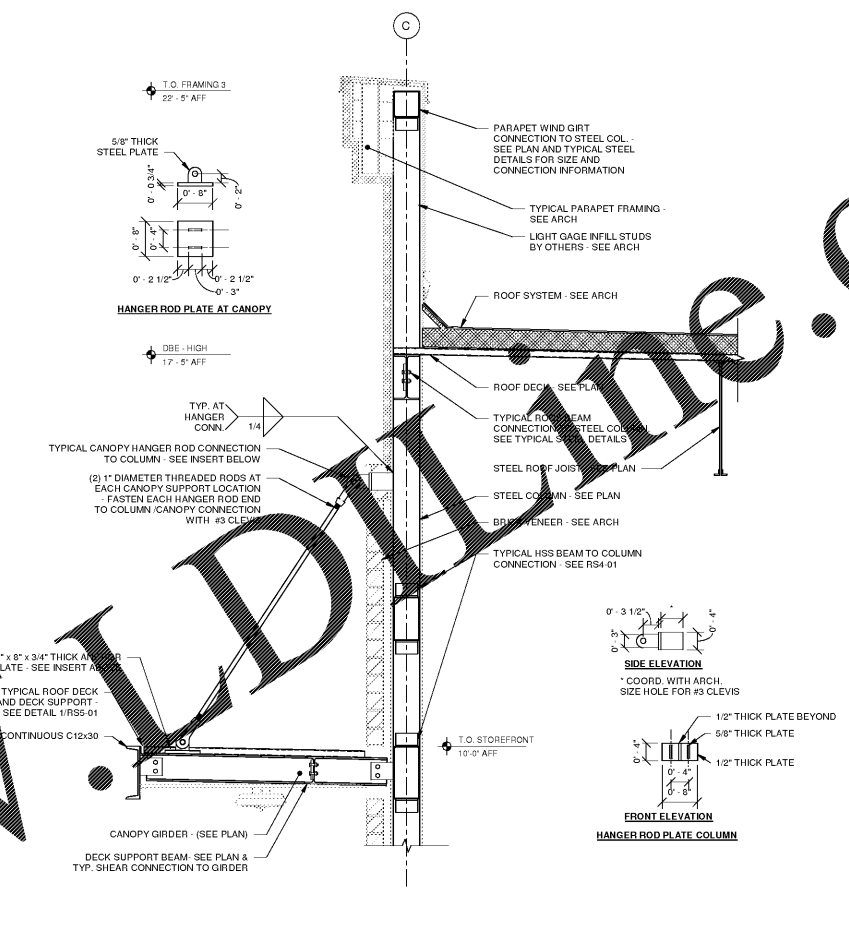

2 SECTION AT HIGH PARAPET RETURN
RS5-02 SCALE: 3/4" = 1'-0"

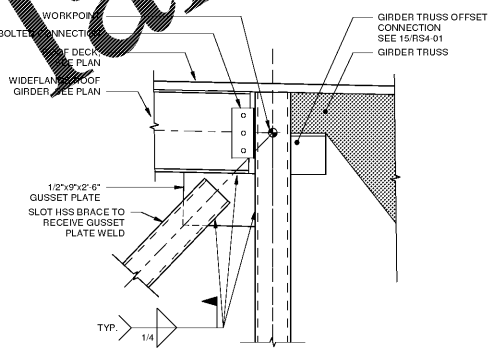

3 BRACE TO BEAM/COLUMN CONNECTION
RS5-02 SCALE: 1" = 1'-0"

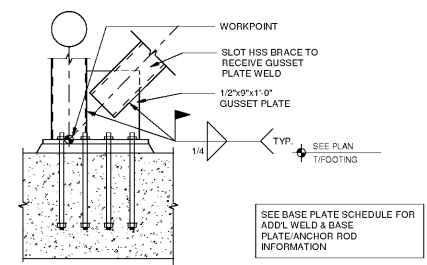

4 BRACE CONNECTION AT FOUNDATION
RS5-02 SCALE: 1" = 1'-0"

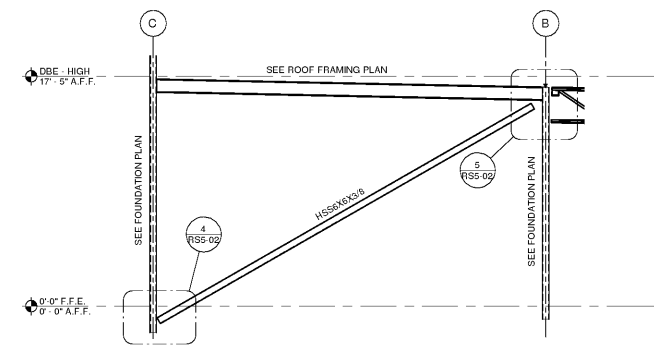

5 BRACED FRAME ELEVATION
RS5-02 SCALE: 3/16" = 1'-0"

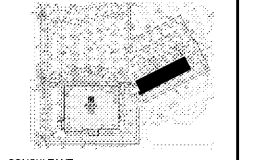
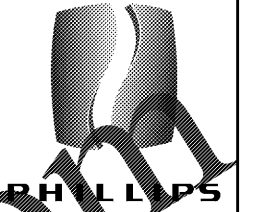

ISSUE & REVISION RECORD

#	DATE	DESCRIPTION
1	08/03/2018	75% COMPLETE SET
2	08/24/2018	100% COMPLETE SET

PROJECT: MARKETPLACE at THE BRAY @ LIBERTY PARK VESTAVIA HILLS, AL

CLIENT: BLACKWATER REAL ESTATE



PHILLIPS JOB NUMBER: 1858001
ISSUE DATE: 08/24/18
DRAWN BY/CHECKED BY: Author / Checker
DRAWING TITLE: STOREFRONT/PARAPET DETAILS

SHEET NUMBER: RS5-02

5901 PEACHTREE DUNWOODY RD. BUILDING A, SUITE 450 ATLANTA, GEORGIA 30328
PHILLIPSPART.COM 770-394-1616