

Signed & Sealed: 31 AUG 2018

Copyright © 2018 YSM Design, P.C.
All rights reserved. Specifications, computer files, text data, notes and other documents and information contained by YSM Design, P.C. are the work product of YSM Design, P.C. and are hereby protected by copyright law.
This drawing shall not be reproduced in whole or in part without written permission of YSM Design, P.C. or its authorized representative. Such as checked and only valid on the original drawing.

Rev	Date	Comments

BID SET
Every Contractor or Subcontractor, by submitting a bid for this project declares that they have reviewed all aspects of this project and have included all work required to provide a complete project that meets all building codes.
If questions or discrepancies are found between trades, bids should be submitted by the building General Contractor as a Request for Information on the bid date. These questions will be issued to all Bidders in Abstract. No consideration will be given after the bid date for issues that could clearly have been assumed during the bidding period.
Information to all Bidders:
For more information about this bid, including a list of the most current documents, instructions to Bidders, Responsibility Chart, answers to RFI, etc., go to project website. Note this address will be provided to bidders with invitation to bid.
It is the responsibility of ALL Bidders to become familiar with this set and the additional information that is contained there. If you do not have access to the internet you MUST contact your General Contractor for this information. NO CHANGE ORDERS will be accepted for additional information.
No consideration will be given for Change Order Requests on any of the following:
1. Items requiring clarification but not clearly indicated as an exception on the bid set.
2. Items requiring clarification but not submitted to Architect as a request for information during bidding.
3. Items deemed to be industry standard for a particular system or assembly.
4. Items that can reasonably be inferred or assumed from contract documents.



Client:
JIM ELLIS CADILLAC
5880 PEACHTREE BLVD
ATLANTA, GA 30341

Project:
JIM ELLIS CADILLAC
5880 PEACHTREE BLVD
ATLANTA, GA 30341

Project Number: 18020
Drawn By: TFL
Checked By: ES / AEA
Approved By: YSM

Sheet Title:
VR ROOM DIVIDER WALL DETAILS

Sheet Number:
A724

WWW.LDILine.com

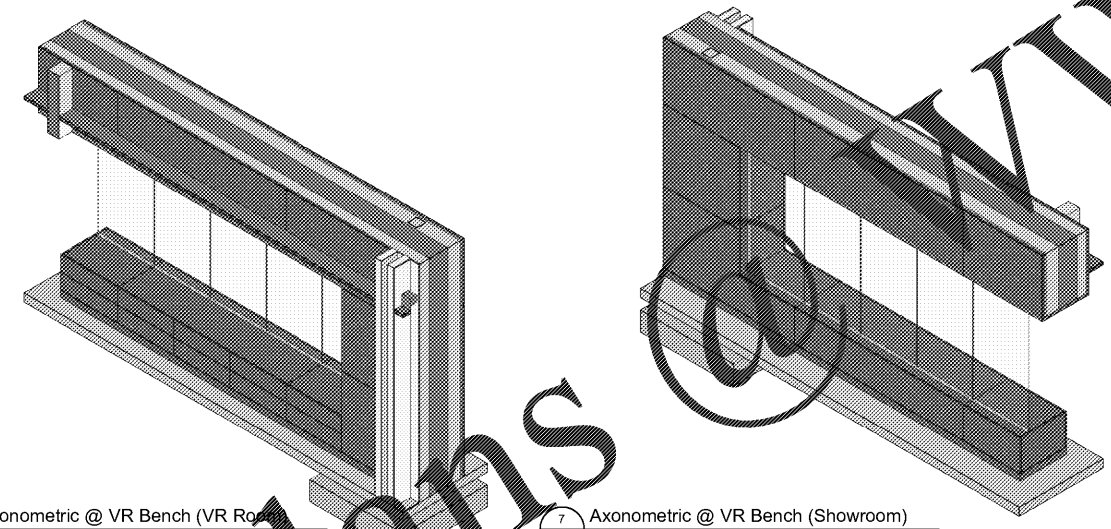

8 Axonometric @ VR Bench (VR Room)
A724

7 Axonometric @ VR Bench (Showroom)
A724

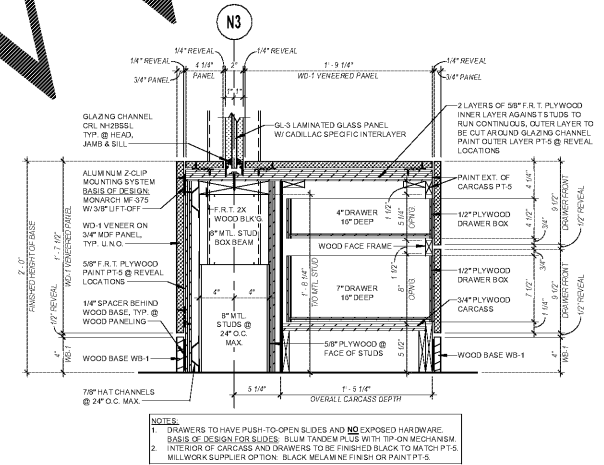

6 MW Detail - VR Room Bench
A724 1 1/2" x 1'-0"

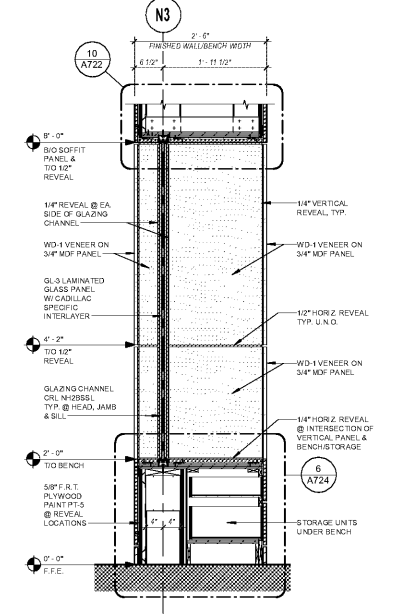

5 MW Section - VR Room Bench
A724 3/4" x 1'-0"

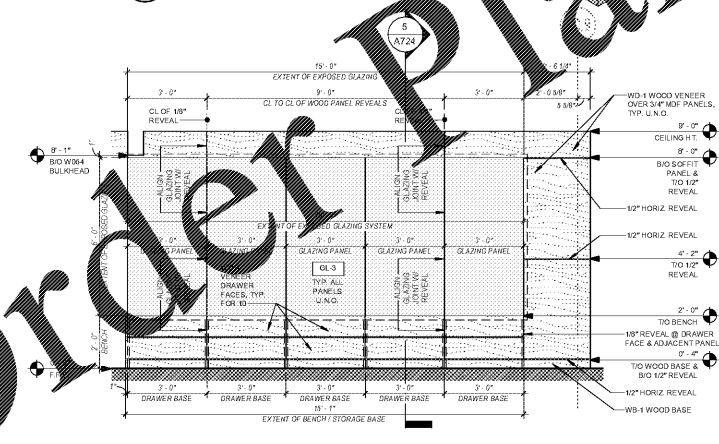

4 MW Elev. - VR Room Bench (VR Room)
A724 3/8" x 1'-0"

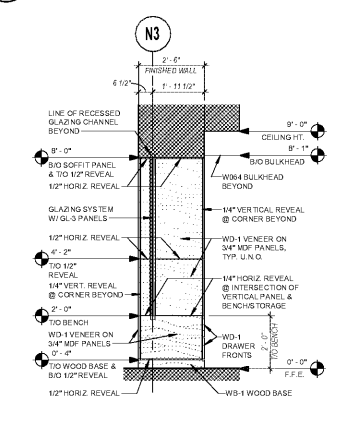

3 Millwork Elev. - VR Room Bench (Passage)
A724 3/8" x 1'-0"

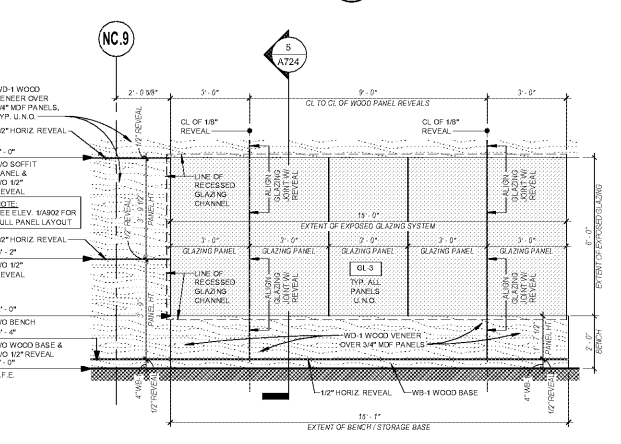

2 MW Elev. - VR Room Bench (Showroom)
A724 3/8" x 1'-0"

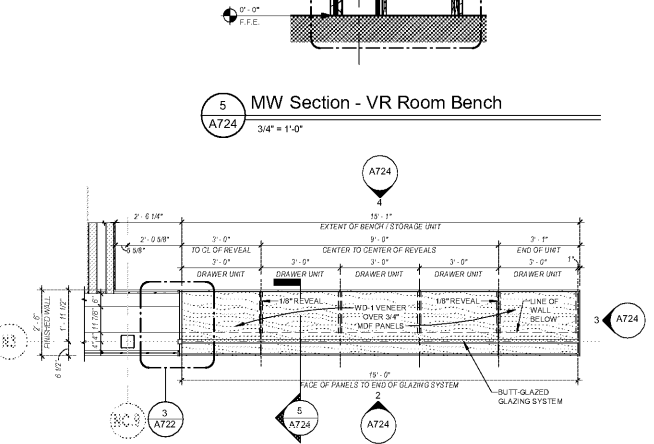

1 MW Plan - VR Room Bench
A724 3/8" x 1'-0"

JIM ELLIS CADILLAC, esanchez vt
D:\esanchez\18020
8/31/2018 4:00 PM

Order Plans