

Signed & Sealed: 31 AUG 2018

Copyright © 2018 YSM Design, P.C.
All rights reserved. Reproduction, computer file, text data, notes and other documents and information contained by this design, P.C. and work of contract, the industry, and shall remain the property of YSM Design, P.C. No part of this document may be reproduced or transmitted in any form or by any means, electronic, mechanical, photocopying, recording, or by any information storage and retrieval system, without the prior written permission of YSM Design, P.C. This is an unrecorded copy request. See the original drawing for the original drawing.

| Rev | Date | Comments |
|-----|------|----------|
| | | |

BID SET
Every Contractor or Subcontractor, by submitting a bid for this project, certifies that they have reviewed all aspects of this project and have included all work required to provide a complete project that meets all building codes.
If questions or discrepancies are found between trades, bidders should be submitted by the building General Contractor as a Request for Information to the Bidder. These questions will be issued to the Bidder in Advance. No consideration will be given after the bid date for issues that could clearly have been answered during the bidding period.
Information to all Bidders:
For more information about this bid, including a list of the most current documents, instructions to bidders, Responsibility Chart, answers to RFI, etc., go to project website. Note this address will be provided to bidders with invitation to bid.
It is the responsibility of ALL bidders to become familiar with this bid and the additional information that is contained therein. If you do not have access to the internet you MUST contact your General Contractor for this information. No Change Orders will be accepted for not reviewing this information.
No consideration will be given for Change Order Requests based on any of the following:
1. Items requiring clarification but not clearly indicated as an exception on the bid.
2. Items requiring clarification but not submitted to Architect as a request for information during bidding.
3. Items that do not meet industry standards for a particular system or assembly.
4. Items that can reasonably be inferred or assumed from contract documents.

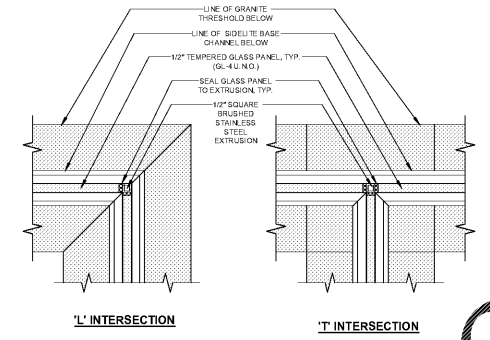

10 INT SF DTL - INTERSECTING PANELS
3" = 1'-0"

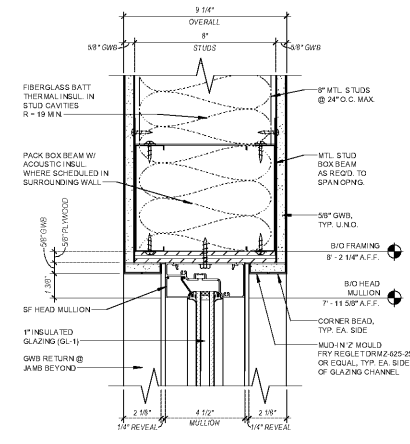

16 INT SF DTL - 451T HEAD (8\"/>

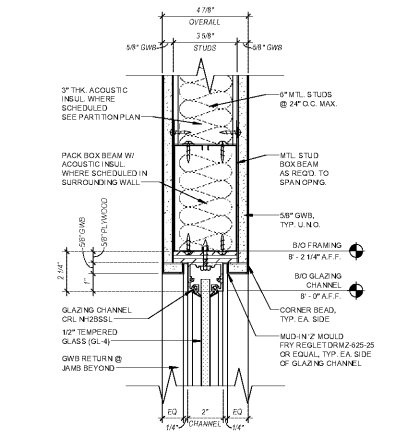

13 INT SF DTL - HEAD (3-5/8\"/>

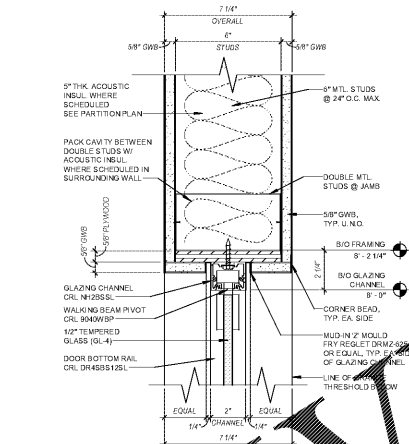

9 INT SF DTL - DOOR HEAD (6\"/>

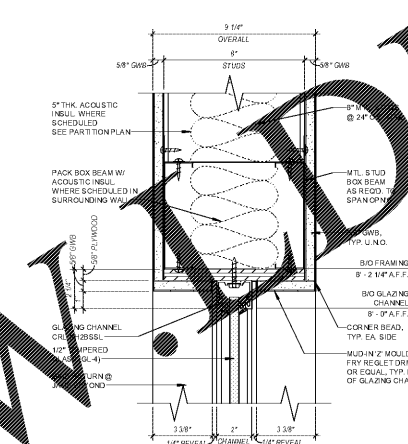

6 INT SF DTL - HEAD (8\"/>

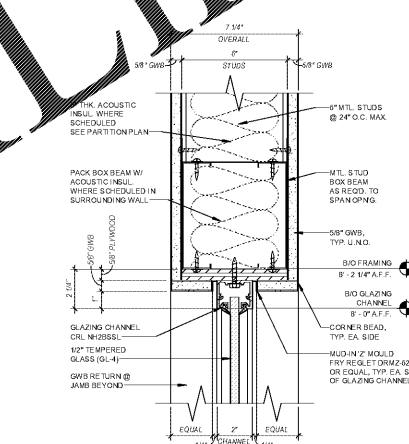

3 INT SF DTL - HEAD (6\"/>

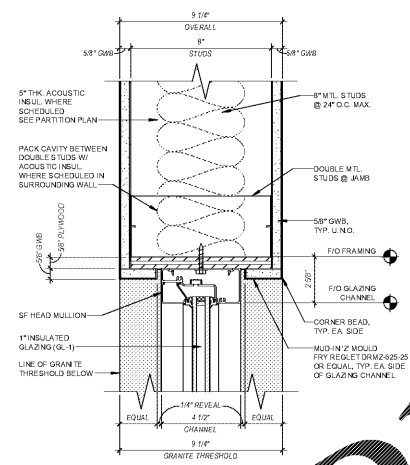

15 INT SF DTL - 451T JAMB (6\"/>

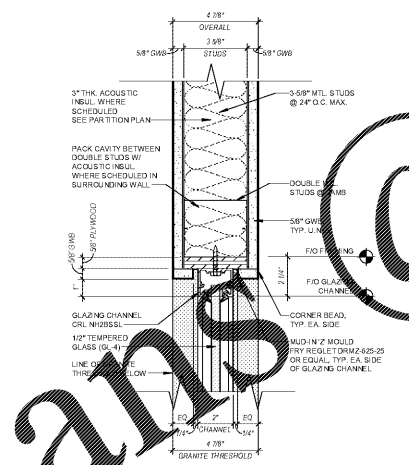

12 INT SF DTL - JAMB (3-5/8\"/>

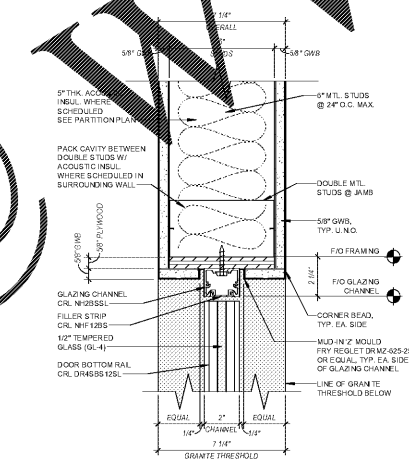

8 INT SF DTL - DOOR JAMB (6\"/>

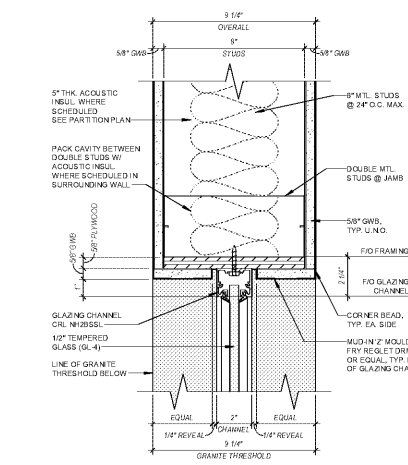

5 INT SF DTL - JAMB (8\"/>

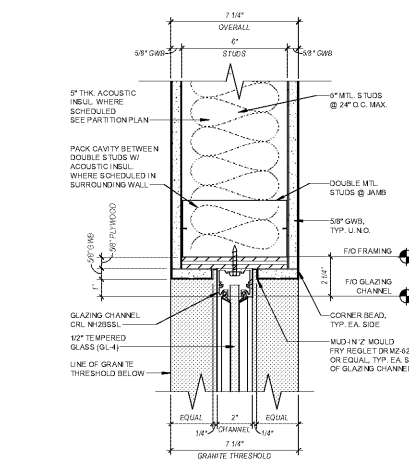

2 INT SF DTL - JAMB (6\"/>



11 INT SF DTL - SILL (3-5/8\"/>

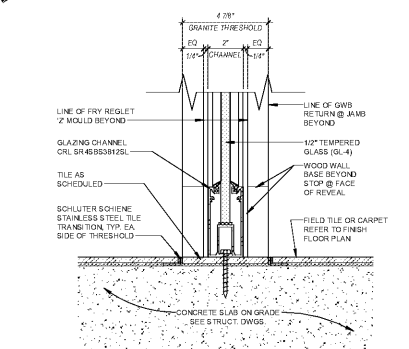

7 INT SF DTL - DOOR SILL (6\"/>

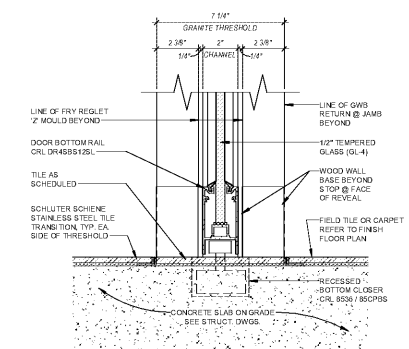

4 INT SF DTL - SILL (8\"/>

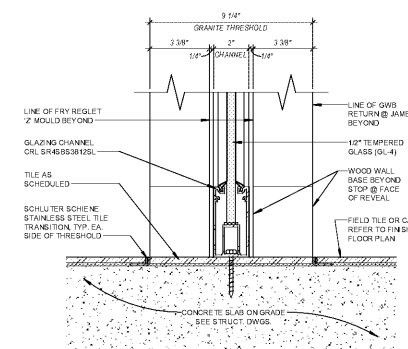

1 INT SF DTL - SILL (6\"/>



Client:
JIM ELLIS CADILLAC
5880 PEACHTREE BLVD
ATLANTA, GA 30341

Project:
JIM ELLIS CADILLAC
5880 PEACHTREE BLVD
ATLANTA, GA 30341

Project Number: 18020
Drawn By: TFL
Checked By: ES / AEA
Approved By: YSM

Sheet Title:
HEAD, JAMB & SILL DETAILS

Sheet Number:
A621

Order Plans @
 JIM ELLIS CADILLAC, esanchez ny
 D:\esanchez\2018\404-249-4555\