



8018 CONCORD MILLS BOULEVARD
CONCORD, NC 28027

CONCORD
NORTH CAROLINA

submission: Date
OWNER/LL REVIEW 11/01/2018
BIG SET 11/01/2018
PERMIT SET 11/01/2018

Description Date

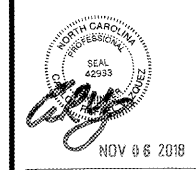

FOUNDATION
DETAILS

S300

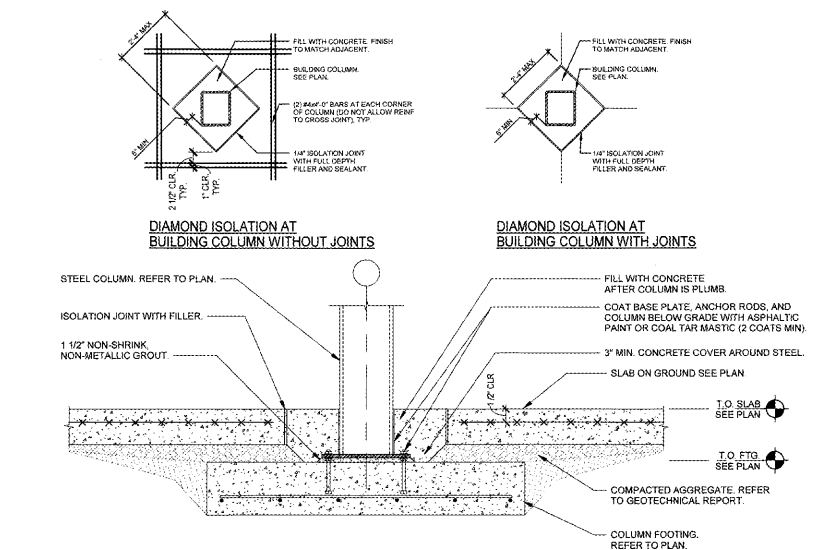

01 column footing detail
SCALE | 3/4" = 1'-0"

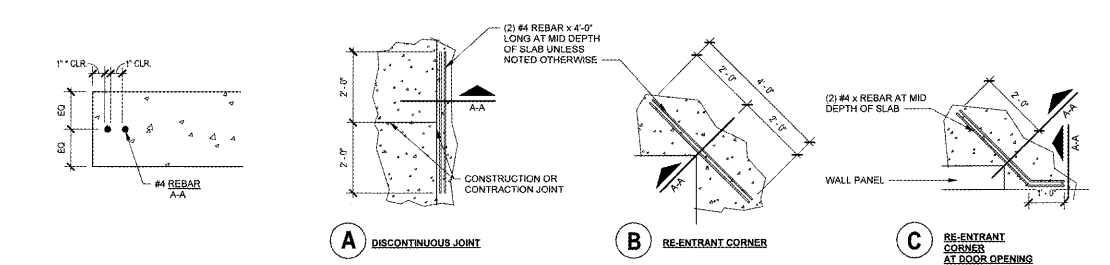

04 slab reinforcement details
SCALE | 1/2" = 1'-0"

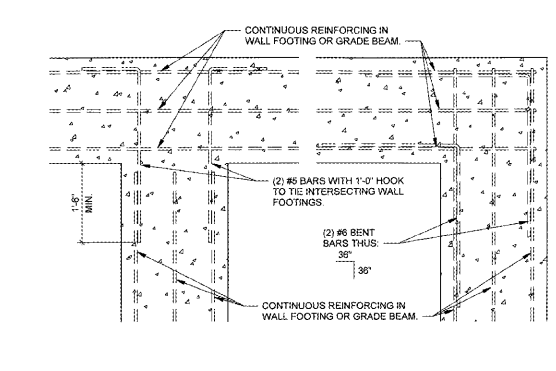

02 intersecting foundations
SCALE | 3/4" = 1'-0"

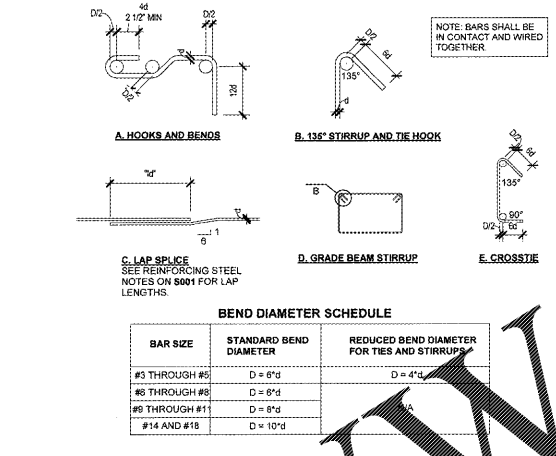

05 typical reinforcing details
SCALE | 1 1/2" = 1'-0"

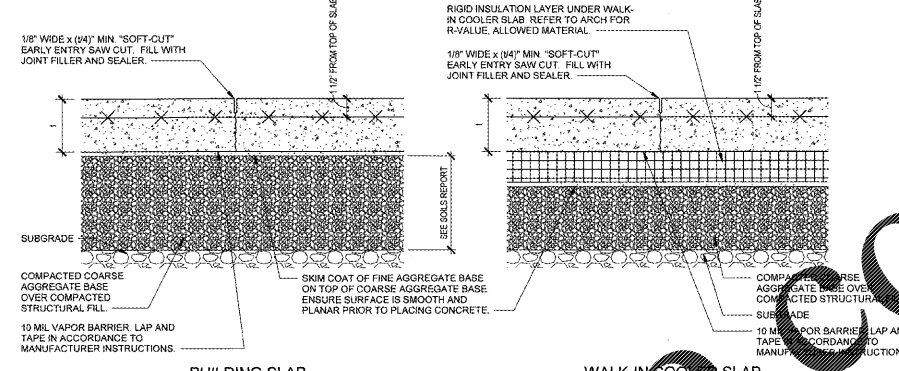

03 typ. slab on ground and control joint construction
SCALE | 1 1/2" = 1'-0"

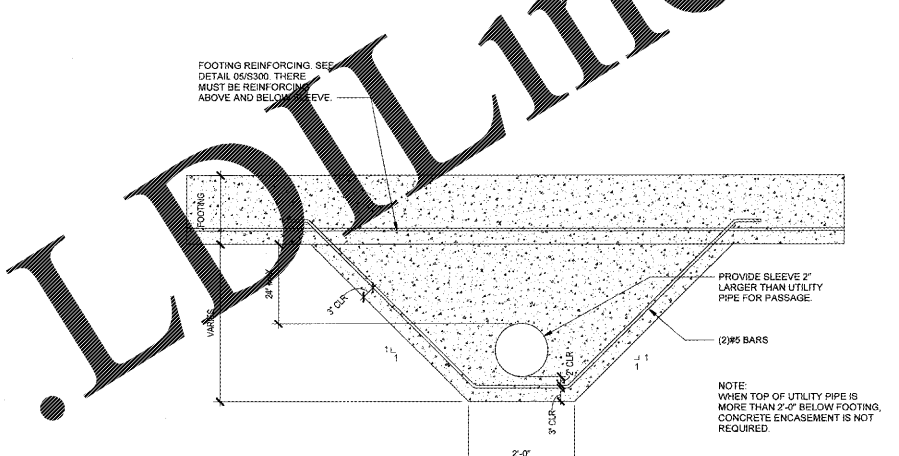

06 pipes under foundations
SCALE | 3/4" = 1'-0"

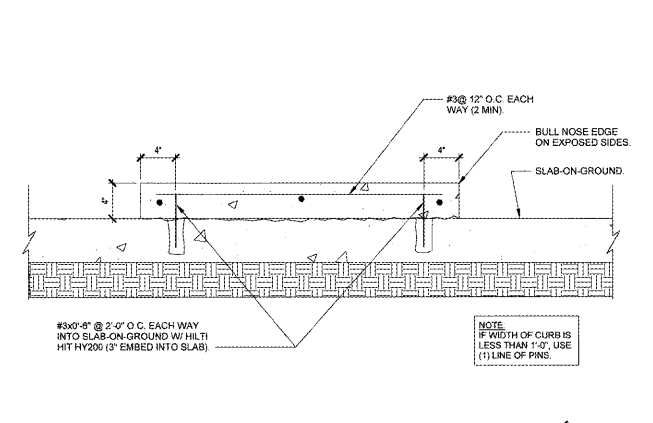

07 equipment curb
SCALE | 1 1/2" = 1'-0"

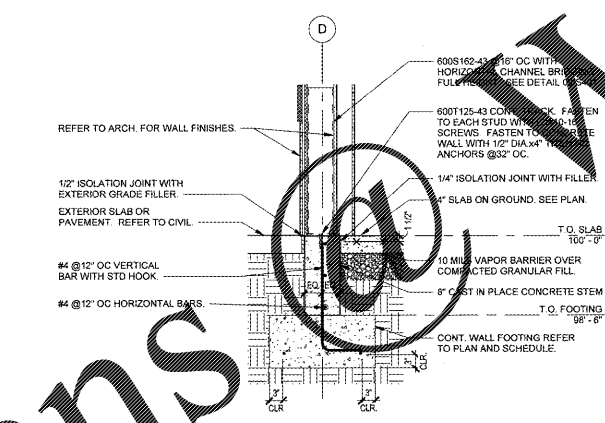

08 perimeter stem wall and footing line D
SCALE | 3/4" = 1'-0"

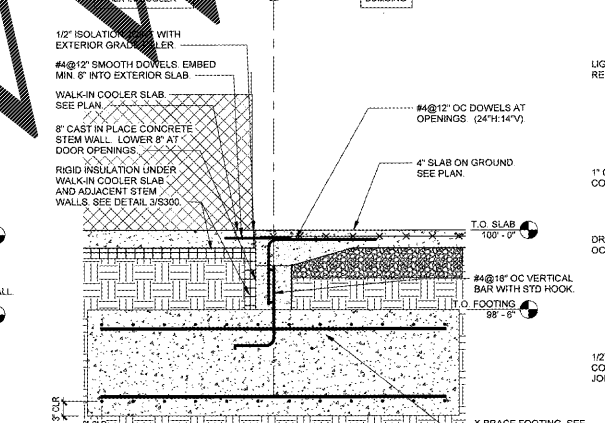

9 foundation section walk-in cooler
SCALE | 3/4" = 1'-0"

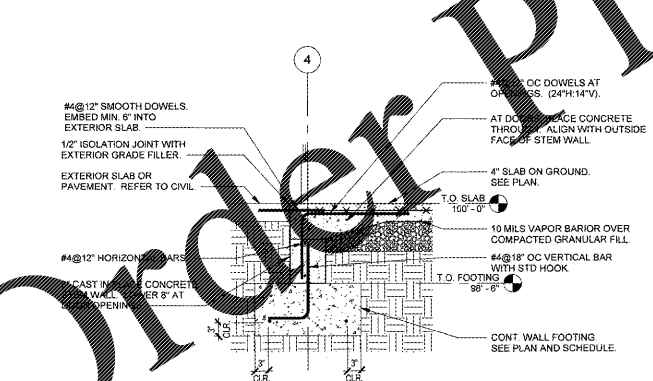

10 perimeter stem wall at openings
SCALE | 3/4" = 1'-0"

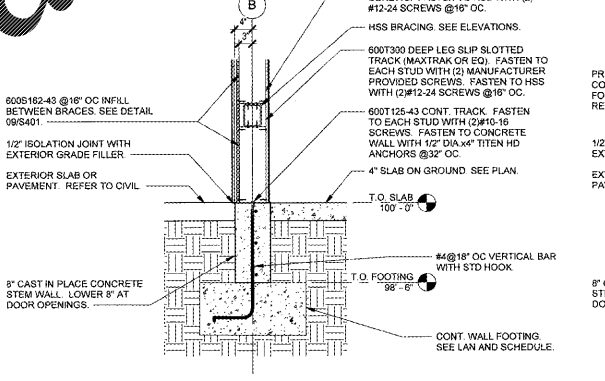

11 perimeter stem wall and footing line B
SCALE | 3/4" = 1'-0"

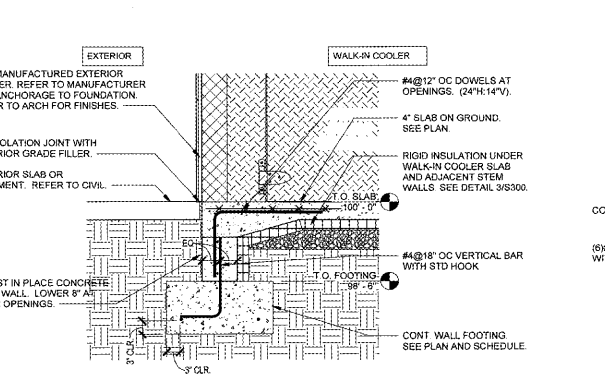

12 perimeter stem wall and footing walk-in cooler
SCALE | 3/4" = 1'-0"

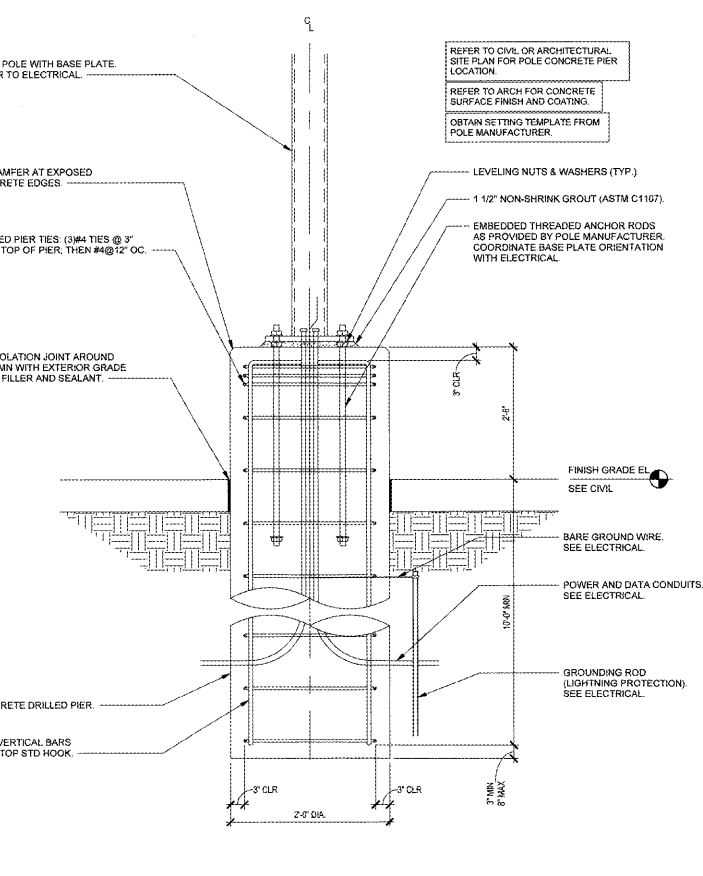

13 light pole drilled pier
SCALE | 3/4" = 1'-0"

Order Plans