

Order Plans @ WWW.DLine.com

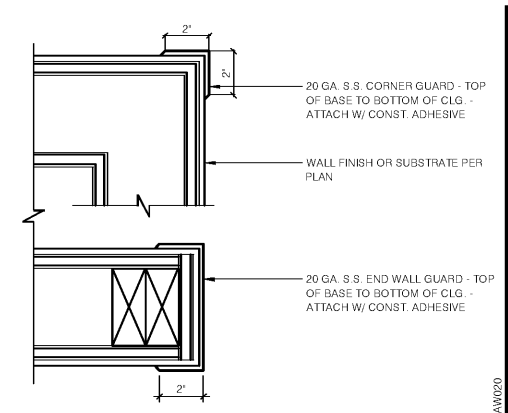

CORNER GUARD 3'-1'-0" 15

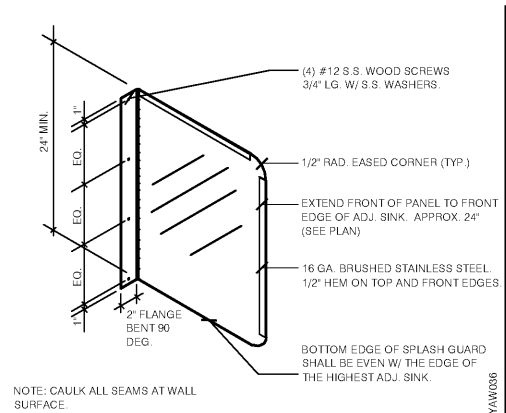

SPLASH GUARD N.T.S. 11

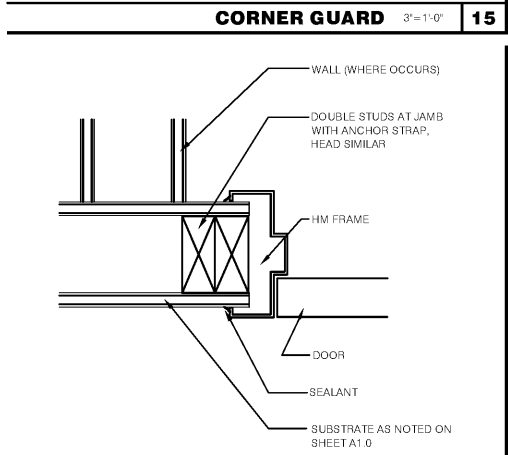

INTERIOR DOOR HEAD / JAMB 3'-1'-0" 14

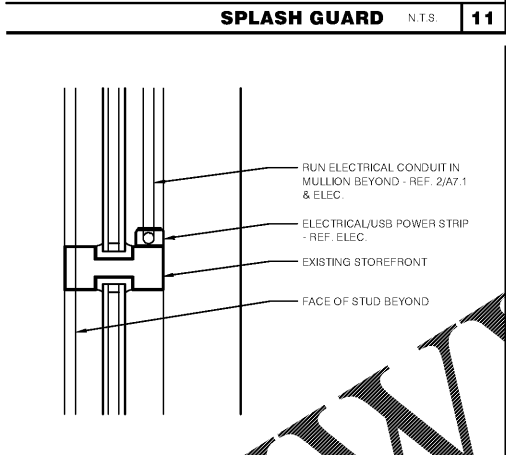

USB & POWER STRIP/MULLION 3'-1'-0" 10

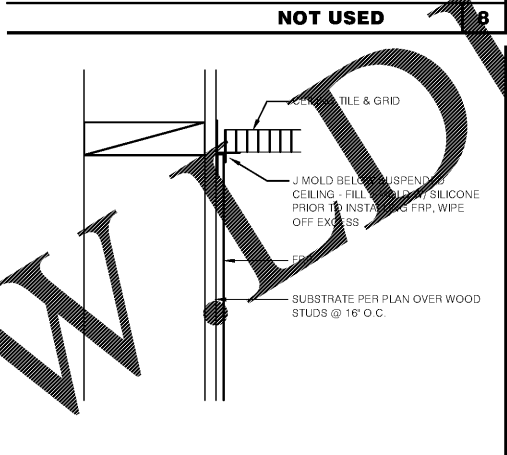

FRP @ CEILING 3'-1'-0" 7

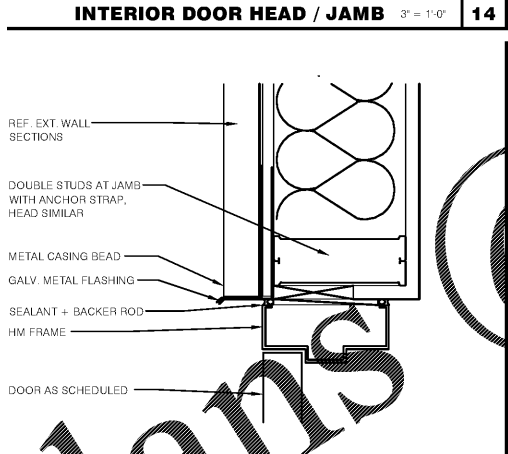

EXTERIOR DOOR HEAD/JAMB 3'-1'-0" 13

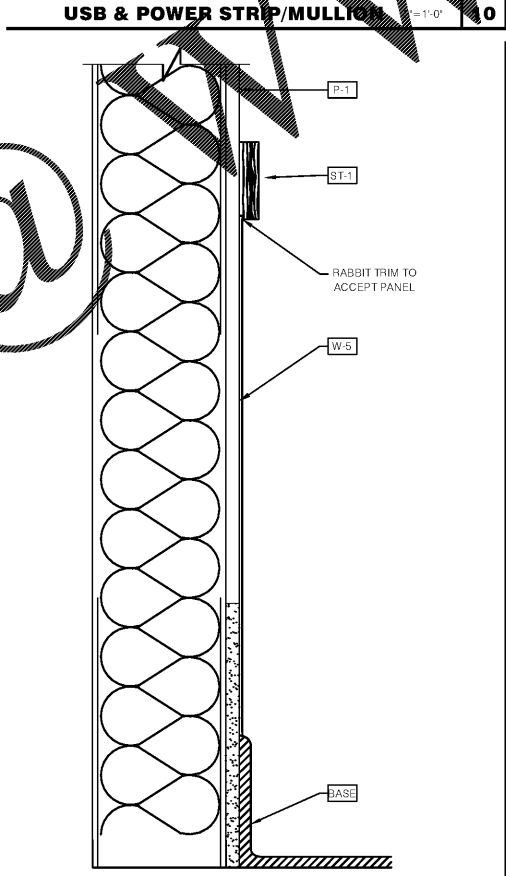

WOOD WAINSCOT & TRIM 3'-1'-0" 9

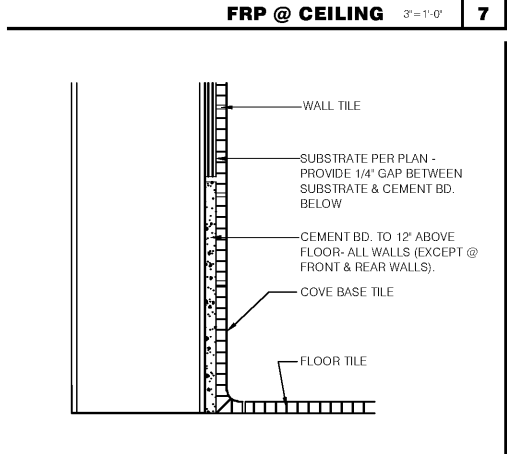

BASE @ RESTROOM 3'-1'-0" 6

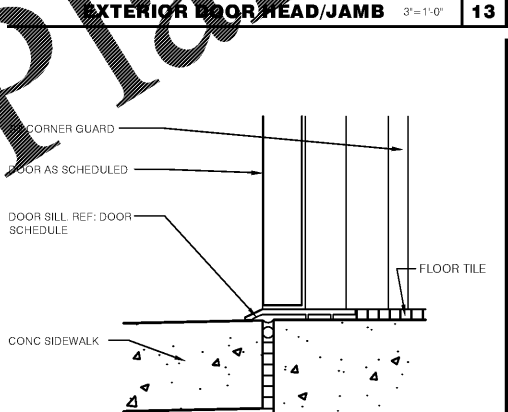

EXTERIOR DOOR SILL 3'-1'-0" 12

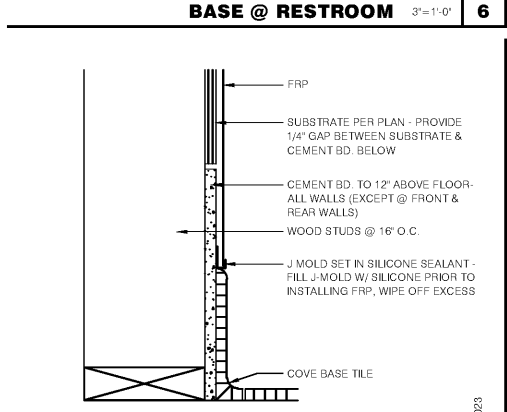

FRP @ KITCHEN BASE 3'-1'-0" 5

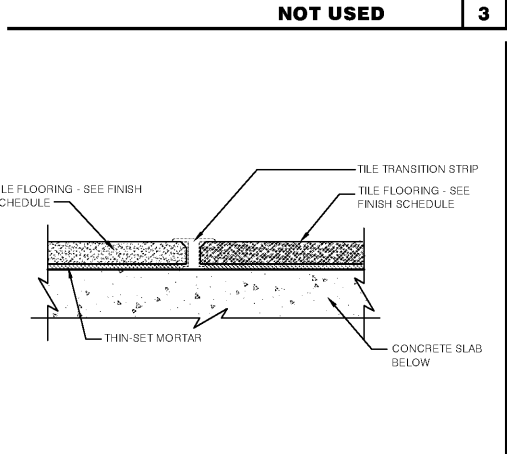

FLOOR TRANSITION 3'-1'-0" 2

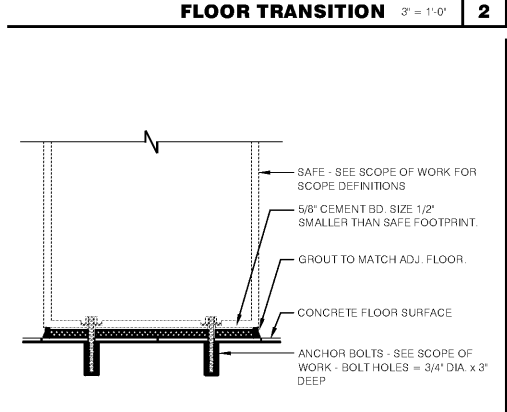

SAFE PEDESTAL 1-1/2'-1'-0" 1

DATE: 10/10/18
JOB NO: 1845
DRAWING: FS
CHECKED: DL

MISC. DETAILS

FRANCHISEE

Pizza Hut International

7300 W. 129TH STREET
OVERLAND PARK, KANSAS 66213
PHONE: (913) 327-5555
FAX: (913) 327-5850

PIZZA HUT #1845
5229 US HWY 231
WETUMPKA, ALABAMA

LICKEL ARCHITECTS

DALE A. LICKEL
PROFESSIONAL ENGINEER
STATE OF ALABAMA
LICENSE NO. 100018

REVISIONS:

SHEET NUMBER
A11