

GENERAL NOTES

- DO NOT SCALE PLANS.
- THE CONTRACTOR SHALL HIRE A SURVEYOR TO LAYOUT THE BUILDING ON THE SITE IN ACCORDANCE WITH THE CIVIL CONSTRUCTION DOCUMENTS.
- THE SURVEYOR AND CONTRACTOR SHALL FIELD VERIFY ALL EXISTING CONDITIONS AND SHALL NOTIFY THE OWNER, ENGINEER AND ARCHITECT OF ALL DISCREPANCIES.
- THE CONTRACTOR SHALL PREPARE THE BUILDING PAD PER THE GEOTECHNICAL REPORT.
- CONTACT LOCAL FIRE DEPARTMENT FOR SERVICE REQUIREMENTS PRIOR TO CONSTRUCTION.
- BURNING OF MATERIALS ON SITE IS NOT PERMITTED. SEE PLUMBING SHEETS P10 AND P13 FOR PLUMBING ROUGH IN DIMENSIONS.
- REFER TO SITE PLAN FOR PRESENTATION OF BUILDING JOINTS BETWEEN CONCRETE SLAB POURS SHALL BE DOWELED. SEE STRUCTURAL DRAWINGS. METAL KEYWAYS SHALL NOT BE USED.

SHEET KEYNOTES

- EDGE OF SIDEWALK TURN DOWN
- EMERGENCY SHUT OFF SWITCH. REFER TO DETAIL ON THIS SHEET
- EXTERIOR LIGHT BOLLARD. REFER TO SITE PLAN FOR SPECIFICATIONS. REFER TO ELECTRICAL DRAWINGS FOR CIRCUIT INFORMATION.
- TRAFFIC BOLLARD. REFER TO DETAIL THIS SHEET.
- SIDEWALK EXPANSION JOINT. REFER TO DETAIL THIS SHEET.
- 6"X6" DOWNSPOUT. TIE TO UNDERGROUND STORM. SEE CIVIL FOR CONTINUATION.
- 3"X3" DOWNSPOUT. TIE TO UNDERGROUND STORM. SEE CIVIL FOR CONTINUATION.
- SLAB TO ALIGN WITH FRONT EDGE OF MASONRY PIER. EXTERIOR LANDING NOT TO EXCEED SLOPE OF 1:48 IN ANY DIRECTION.
- ALIGN JOINT WITH 90 DEGREE TURN IN SIDEWALK LAYOUT. CONVENIENCE OUTLET MOUNTED IN WALL. REFER TO ELECTRICAL DRAWINGS.
- DASHED LINE INDICATES PATIO ROOF ABOVE.
- CAST STONE PIER CAP. REFER TO FLOOR REFERENCE PLANS FOR MORE INFORMATION.
- TABLES AND CHAIRS TO BE BOLTED TO SLAB.
- ALIGN JOINT WITH FACE OF CONCRETE OF PIER IN THIS LOCATION.
- CONTROL JOINT AT EDGE OF BROOM FINISH CONCRETE AT PATIO.
- LOCATE PROPANE CAGE 5' AWAY FROM ANY ELECTRICAL OUTLET.
- BOLLARD. SEE CIVIL FOR EXTENSION OF SITE PLAN.
- 3" DOWNSPOUT. TIE TO UNDERGROUND STORM. SEE CIVIL FOR CONTINUATION.

SIDEWALK PLAN LEGEND

- E.J. EXPANSION JOINT
- CL CENTER LINE
- LB LIGHT BOLLARD

RaceTrac
COPYRIGHT NOTICES
 THESE PLANS ARE SUBJECT TO FEDERAL COPYRIGHT LAWS. ANY USE OF SAME WITHOUT THE EXPRESSED WRITTEN PERMISSION OF RACETRAC PETROLEUM, INC. IS PROHIBITED. 2016 RACETRAC PETROLEUM, INC.

DESIGN PROFESSIONALS
CONTR
 HILL FOLEY ROSSI & ASSOCIATES
 ARCHITECTURE
 ENGINEERING
 3680 Pleasant Hill Road
 Suite 200
 Duluth, Georgia 30096
 p 770.622.9858
 f 770.622.9535
 www.hillfoleyrossi.com

ISSUE/REVISION RECORD

DATE	DESCRIPTION
08/21/18	ISSUED FOR PERMIT

RaceTrac
 RACETRAC PETROLEUM, INC.
 200 GALLERIA PARKWAY SOUTHEAST
 SUITE 900
 ATLANTA, GEORGIA 30339
 (770) 431-7600

PROJECT NAME
EAST MAIN STREET

CARTERSVILLE GEORGIA
 1325 E. MAIN ST.
 CARTERSVILLE, GA 30121

RACETRAC STORE NUMBER
1310

PROTOTYPE SERIES 5.5K 2.0
2018 RH 00

PLAN MODIFICATION NOTICE

SPB NO. DATE

STANDARD PLAN BULLETINS (SPB) MODIFY THE PROTOTYPE SERIES SET NOTED ABOVE. THE LISTED SPB REPRESENTS THE LATEST MODIFICATION INCORPORATED TO THIS PROTOTYPE SERIES SET AT ORIGINAL RELEASE. THE ISSUE/REVISION RECORD COLUMN ABOVE LISTS ANY REVISIONS OR SPB INCORPORATED IN THIS SET AFTER THE ORIGINAL RELEASE. CONTACT RACETRAC ENGINEERING AND CONSTRUCTION FOR ANY SUBSEQUENT BULLETINS NOT INCORPORATED HEREIN.

PROFESSIONAL SEAL

STATE OF GEORGIA
 JON B. ERICKSON
 REGISTERED PROFESSIONAL ARCHITECT
 08/21/18

PROJECT NUMBER
 18.714.00

SHEET TITLE
EXTERIOR SIDEWALK PLAN AND DETAILS

SHEET NUMBER
A100
 ISSUED FOR PERMIT

5 EXTERIOR SIDEWALK PLANS
 3/16" = 1'-0"

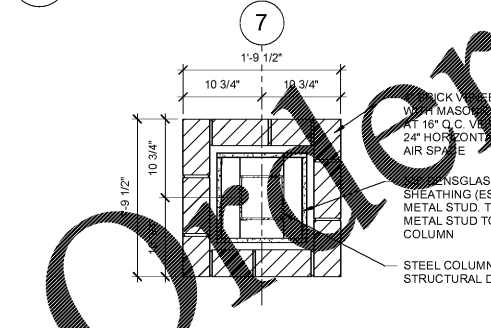

7
 1'-9 1/2" = 1'-0"

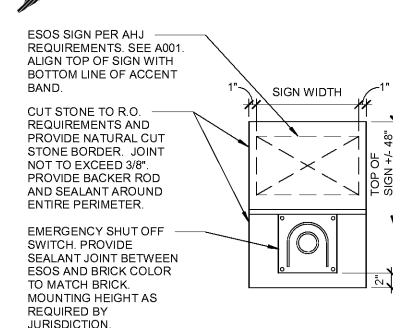

2
 1 1/2" = 1'-0"

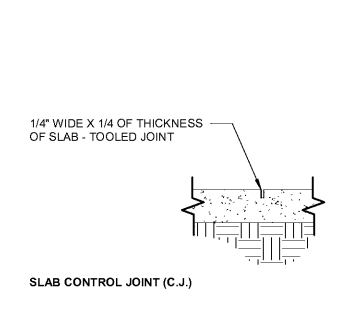

1
 1" = 1'-0"

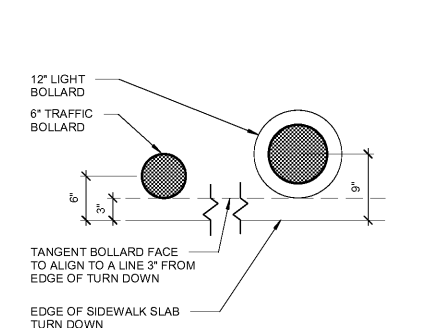

4
 1" = 1'-0"



3
 1" = 1'-0"



2
 1 1/2" = 1'-0"



1
 1" = 1'-0"

