

6.1A-ACTIVE JOB FILED 02/08/2018 07:18 AM - MURPHEY MIDDLE SCHOOL PE BUILDING AND PARKING IMPROVEMENTS/AC-DRAWINGS/02/08/2018 11/22/2018 9:59 AM

CAUTION BURIED WATER LINE BELOW

CAUTION BURIED SEWER LINE BELOW

CAUTION BURIED FIBER OPTIC LINE BELOW

NOTES:
 1. DIMENSIONS SHOWN SHALL BE BY FIELD, MAKING TIES WITH A MINOR 1/8" ALLOWANCE.
 2. ALL WORK SHALL BE IN ACCORDANCE WITH THE LATEST EDITIONS OF THE AIA/CES CODE BOOK.
 3. ALL WORK SHALL BE IN ACCORDANCE WITH THE LATEST EDITIONS OF THE AIA/CES CODE BOOK.
 4. ALL WORK SHALL BE IN ACCORDANCE WITH THE LATEST EDITIONS OF THE AIA/CES CODE BOOK.

DATE: 11/20/18
 DRAWN BY: MAB/RDS
 CHECKED BY: TMP
 APPROVED BY: MBM

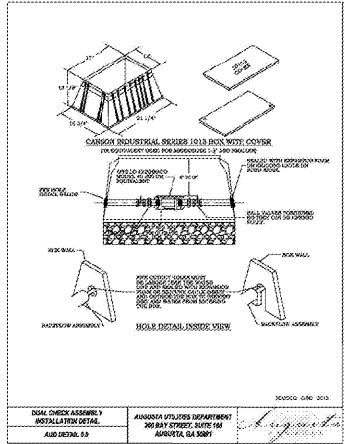
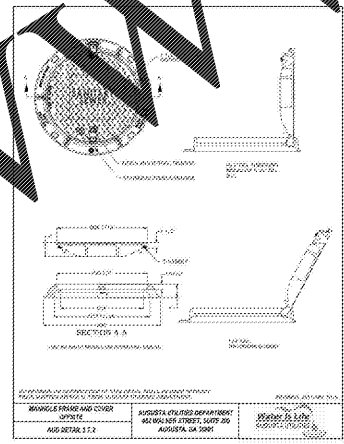
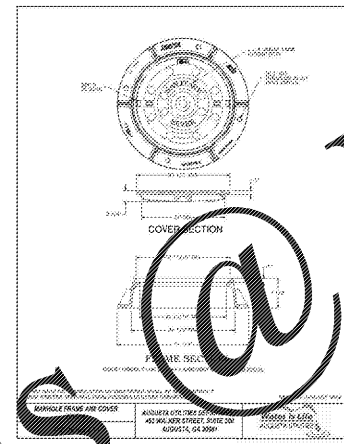
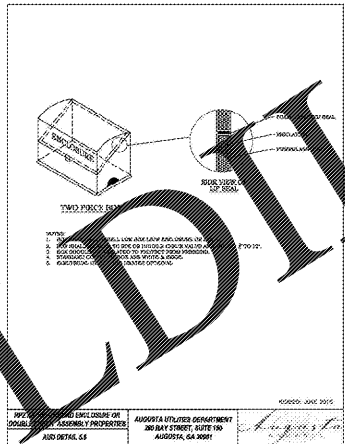
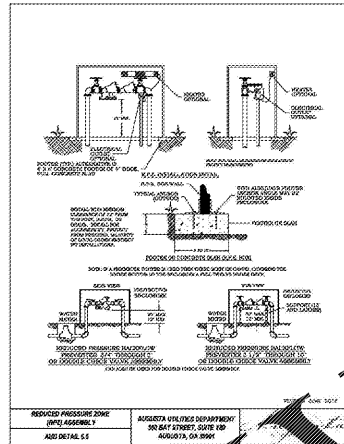
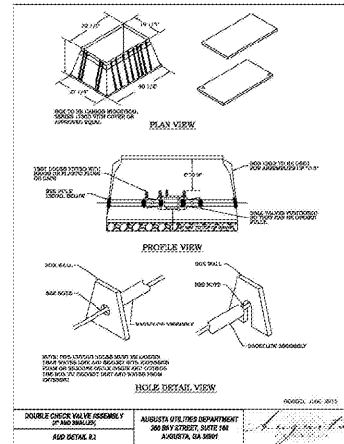

BRANSTON
 ENGINEERING
 ENGINEERS - PLANNERS - SURVEYORS
 450 Ellis Street, Augusta, Georgia 30901
 Post Office Box 1000, Augusta, Georgia 30903
 Phone: (706) 722-1538
 Email: info@branstoneng.com



Murphey Middle School PE Building

Utility Details

DRAWN BY: MAB/RDS
 CHECKED BY: TMP
 APPROVED BY: MBM
 DATE: NOVEMBER 2, 2018
 SCALE: AS SHOWN
 JOB No. 2018-0178
 DRAWING No. C704

dickinson
 ARCHITECTS
 Architecture | Interior Design | Planning
 771 Broad Street, Suite 500
 Augusta, Georgia 30901
 Phone: (706) 722-7488
 Email: info@dickinsonarchitects.com
 www.dickinsonarchitects.com

Member of the American Institute of Architects

THIS DRAWING IS THE PROPERTY OF DICKINSON ARCHITECTS. IT IS NOT TO BE REPRODUCED OR COPIED IN WHOLE OR IN PART OR FOR ANY PURPOSES WITHOUT THE WRITTEN CONSENT OF DICKINSON ARCHITECTS. DICKINSON ARCHITECTS, P.C., AND ITS AFFILIATED COMPANIES ARE NOT RESPONSIBLE FOR ANY ERRORS OR OMISSIONS IN THIS DRAWING.

PROJECT TITLE:
MURPHEY MIDDLE SCHOOL PE BUILDING
 PROJECT #
B-17-005-3756.1

REVISIONS			
REV #	DATE	APPRD BY	REVISION
1	11/02/18	MBM	STATE FINAL
2	11/20/18	MBM	ISSUE FOR BID

DA PROJECT NUMBER & NAME:
 1707.1

DRAWING TITLE:
UTILITY DETAILS

DRAWING NO:
C704