

CITY OF BREMEN GA SIGNAGE CODE  
 EXISTING PROPERTY ZONING IS "C2 - NEIGHBORHOOD AND HIGHWAY BUSINESS"

ON-PREMISE FREE-STANDING SIGN, WITH THE EXCEPTION OF A FIFTY (50') FOOT WIDE CORRIDOR ADJACENT TO THE NORTH AND SOUTH RIGHTS-OF-WAY OF INTERSTATE-20, WHEREIN A REAR LOT SIGN MAY BE PERMITTED, NO MORE THAN ONE (1) ON-PREMISE FREE-STANDING SIGN SHALL BE ALLOWED PER LOT. THIS TYPE OF SIGN WILL GENERALLY BE FOR THE PURPOSE OF DIRECTING THE ATTENTION OF THE VIEWER TO AN ACTIVITY OR SERVICE THAT TAKES PLACE ON THE PROPERTY UPON WHICH THE SIGN IS LOCATED, OR TO A PRODUCT BEING PRODUCED, MANUFACTURED, OR FOR SALE ON SAID PROPERTY. THIS SIGN SHALL BE MOUNTED PERPENDICULAR TO THE STREET ADJACENT TO THE PROPERTY UPON WHICH THE SIGN IS LOCATED, AND SHALL CONTAIN THE STREET IDENTIFICATION NUMBER. ENGINEERING PLANS FOR SAID SIGNS SHALL BE SUBMITTED TO THE COMMUNITY DEVELOPMENT DEPARTMENT FOR APPROVAL PRIOR TO ERECTION.

PROPERTY IN NON-RESIDENTIAL ZONING DISTRICTS, NOT ADJACENT TO I-20; FRONT SIGN LOT ONLY. ON A LOT WHICH IS: A) LOCATED IN A NON-RESIDENTIAL ZONING DISTRICT, AND B) DOES NOT HAVE FRONTAGE ON THE LIMITED ACCESS RIGHTS-OF-WAY OF INTERSTATE 20, ONLY ONE (1) FREE-STANDING SIGN SHALL BE PERMITTED. THE SIGN HEIGHT OF THE PERMITTED SIGN SHALL NOT EXCEED THIRTY-FIVE (35') FEET AND THE FACE OF THE SIGN SHALL NOT EXCEED EIGHTY (80) SQUARE FEET (ONE HUNDRED SIXTY SQUARE FEET FOR A TWO-SIDED SIGN). THE SIGN SHALL BE SET BACK A MINIMUM OF TEN FEET (10') FROM THE RIGHT OF WAY OF THE PUBLIC STREET OR ROAD ADJACENT TO THE LOT ON WHICH SAID SIGN IS LOCATED, OR FIVE FEET (FROM THE OUTER EDGE OF THE SIDEWALK, WHERE APPLICABLE).

**WALL SIGNS**

THREE (3) WALL SIGNS ARE PERMITTED TO BE PLACED ON THE BUILDING. THE FACE OF EACH SIGN SHALL NOT EXCEED THE GREATER OF EITHER 1) SEVENTY-FIVE (75) SQUARE FEET, OR 2) TWO (2) SQUARE FEET PER LINEAR FOOT OF THE WALL UPON WHICH THE SIGN IS PLACED. NO MORE THAN ONE (1) SIGN PER WALL SHALL BE PERMITTED.



AMERICAN DAIRY QUEEN  
 MINNEAPOLIS, MN U.S.A.  
 REGISTERED U.S. PATENT OFFICE. AMERICAN DAIRY QUEEN CORPORATION. THIS DRAWING, ITS DESIGN DETAIL AND INVENTION ARE THE PROPERTY OF AMERICAN DAIRY QUEEN INC. (ADQ) AND SHALL NOT BE COPIED IN ANY MANNER NOR DISCLOSED TO ANY OUTSIDE PARTY WITHOUT ADQ CONSENT.

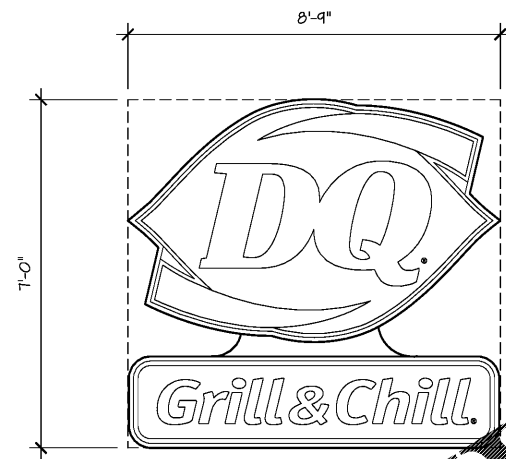

Z DAIRY QUEEN LOGO AND GRILL & CHILL (ILLUM.) CUSTOM SIGN RECTANGULAR = 61.2 SF

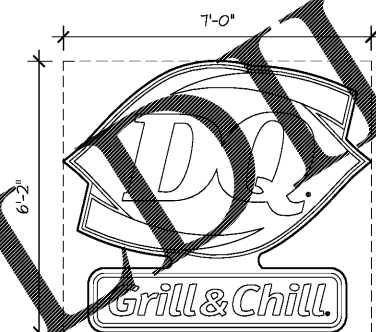

X DAIRY QUEEN LOGO AND GRILL & CHILL (ILLUM.) CUSTOM SIGN RECTANGULAR = 43.1 SF

2 FRONT FACADE SIGNAGE  
 A3.3 SCALE: 1/2" = 1'-0"

3 ENTRANCE FACADE SIGNAGE  
 A3.3 SCALE: 1/2" = 1'-0"

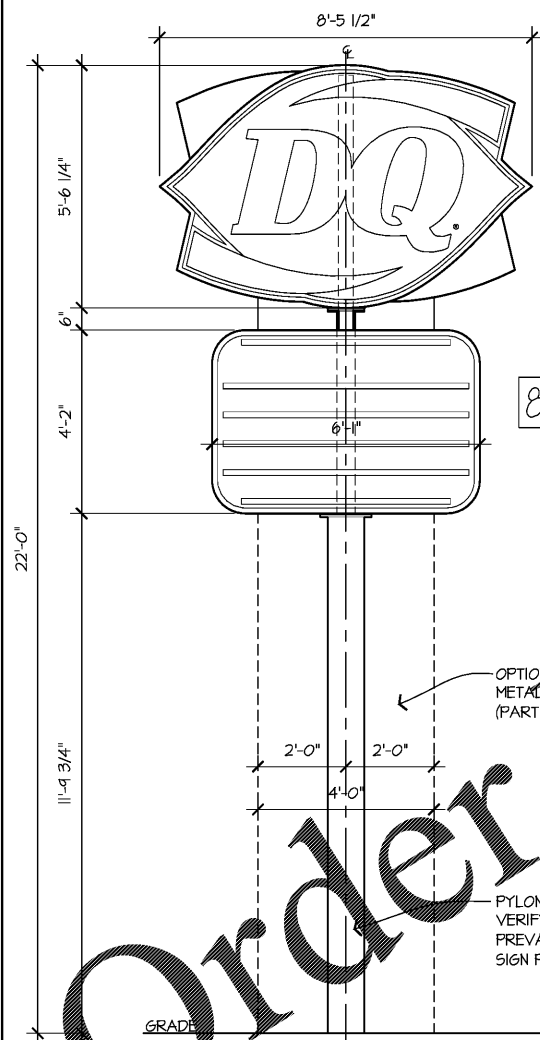

H 5'-6"x8'-5" (NOMINAL) DAIRY QUEEN LOGO (ILLUM.) PROFILE = 33.1 SF RECTANGULAR = 46.7 SF

82 50" X 73" READER BD. (ILLUM.) PROFILE = 24.46 SF RECTANGULAR = 25.0 SF

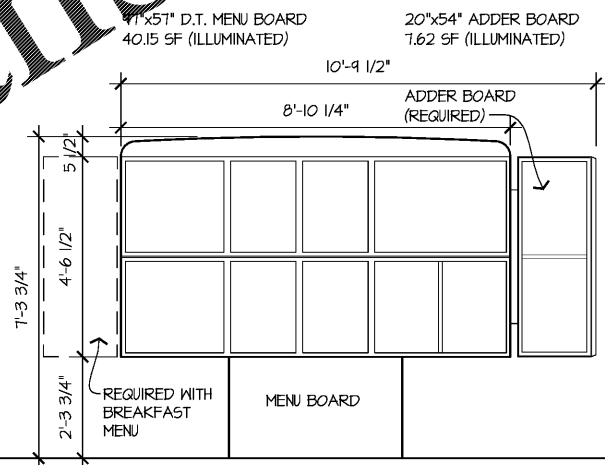

DRIVE THRU MENU BOARD

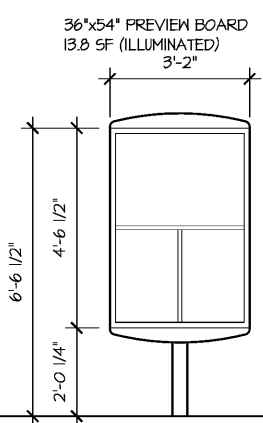

PRE-VIEW MENU BOARD

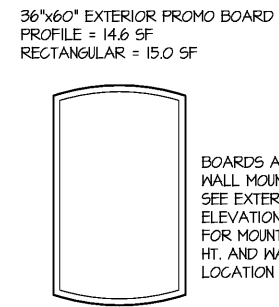

EXTERIOR PROMO BOARD

Order Plans @

1 SITE SIGNAGE  
 A3.3 SCALE: 1/2" = 1'-0"



GEORGIA ARCHITECT LICENSE  
 NUMBER RA014022

**SPECIAL NOTICES**  
 In the event the client consents to, allows, authorizes or approves of changes to any plans, specifications or other construction documents, and these changes are not approved in writing by the design professional, the client recognizes that such changes and the results thereof are not the responsibility of the design professional. Therefore, the client agrees to release the design professional from any liability arising from the construction, use or result of such changes. In addition, the client agrees to the fullest extent permitted by law, to indemnify and hold the design professional harmless from any damage, liability or cost (including reasonable attorney's fees and costs of defense) arising from such changes. Copyright © 2018 by John S. Odom, Architect. All rights reserved. No part of this drawing may be reproduced by photocopy or by any other means, or stored, processed, or transmitted in or by any computer or other systems without the prior written permission of the Architect.

ISSUE DATE:	11-01-18
REVISION DATE:	11-01-18
	ORIGINAL ISSUE
▲	
▲	

**SIGNAGE MATRIX**

SHEET NUMBER:  
**A3.3**