

SANITARY SEWER CLEANOUT DETAIL

NOT TO SCALE

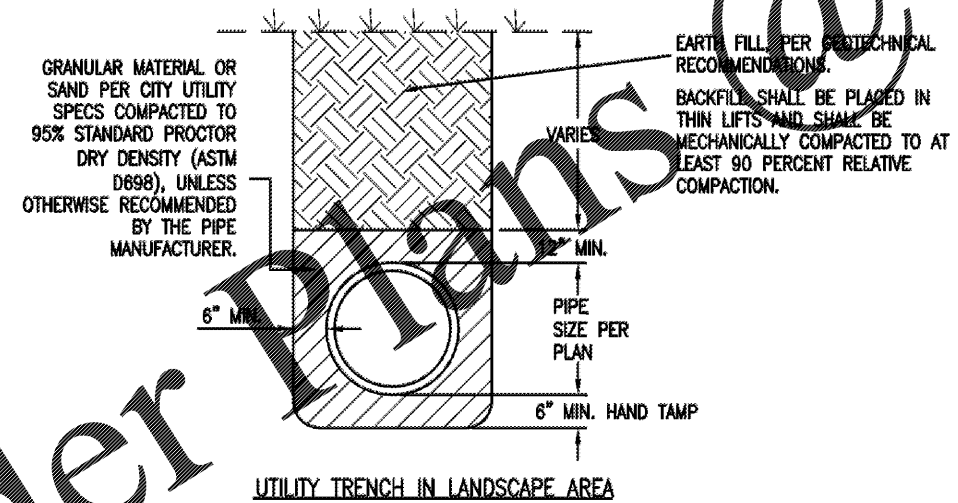
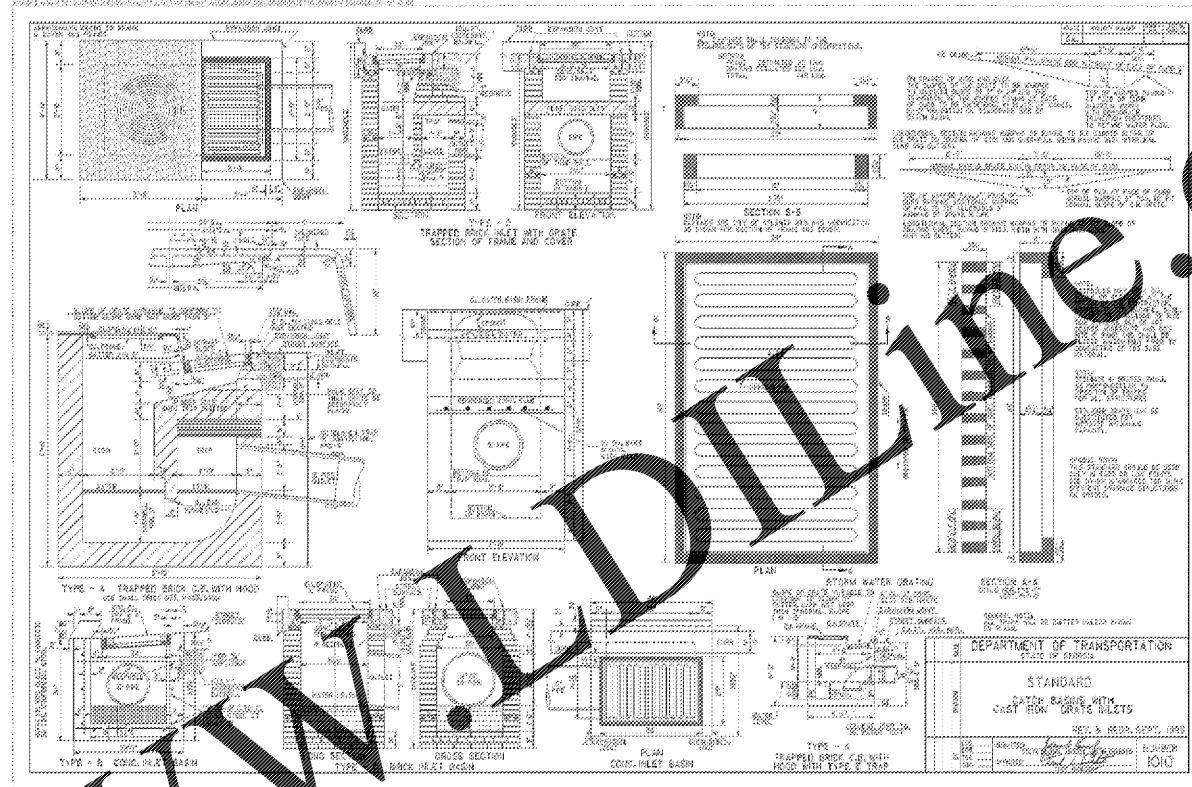

UTILITY TRENCH DETAIL

NOT TO SCALE

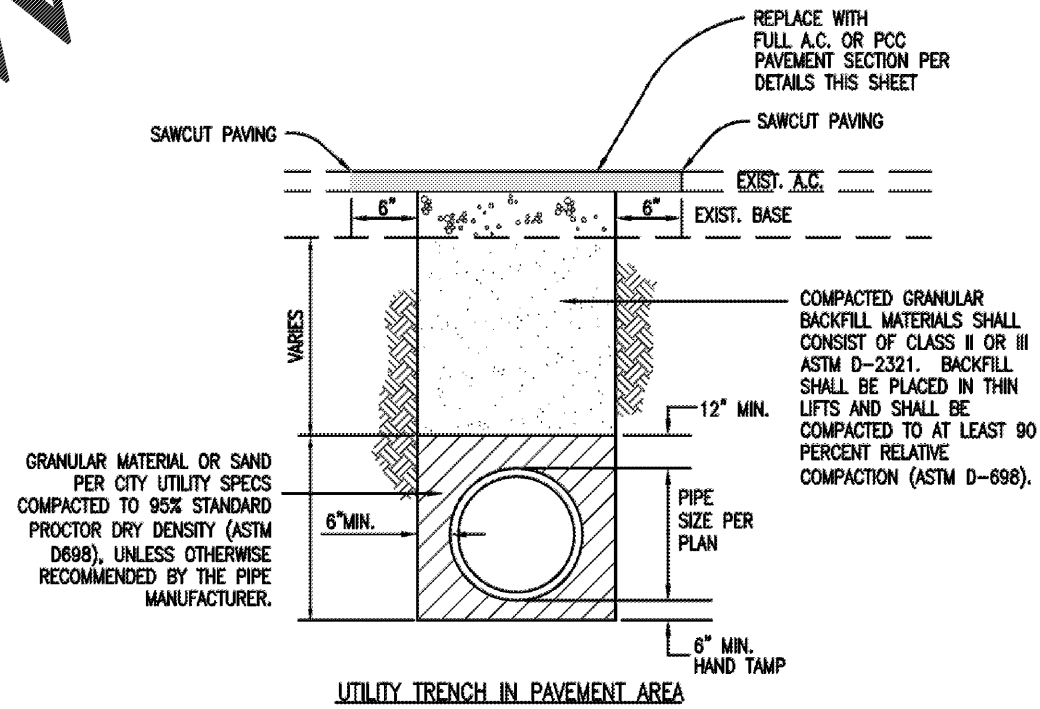

*CONTRACTOR TO FOLLOW SPECIFIC UTILITY TRENCH DETAILS AS REQUIRED BY UTILITY PROVIDERS. CONSULT WITH ENGINEER PRIOR TO UTILITY TRENCH CHANGES PER DETAILS

Architect:

 JOHN S. M. ARCHITECTS
 98 N. WASHINGTON STREET, SUITE 200
 ATLANTA, GA 30309
 TEL: 404.525.2500
 FAX: 404.525.2501
 WWW.JSMARCHITECTS.COM

Civil Engineer:

 REYLING DESIGN & CONSULTING
 4516 Boardwalk | Smithton, IL | 62285
 reylingdc@gmail.com

LICENSE EXPIRES - 12.31.2018
 DATE SIGNED - 10.30.2018

ENGINEER OF RECORD:
 Todd J. Reyling, PE
 Georgia PE 041448

ISSUED / REVISED	DATE
ISSUED FOR REVIEW	10.30.2018

PROJECT NUMBER: 18-163

New Ground Up Building:
DAIRY QUEEN
 Alabama Ave. & Davis Road
 Bremen, GA 30110
 Carroll County

Construction
 Details
C701

Order